



# HIGH RISE BLADE (60") KIT

P/N 31-0060

## ASSEMBLY / SPARE PARTS MANUAL

### Application

PLOW PUSH FRAME NO. 33-0000

Before you begin, please read these instructions and check to be sure all parts and tools are accounted for. The following instructions contain details required to install and service the contents of this kit.

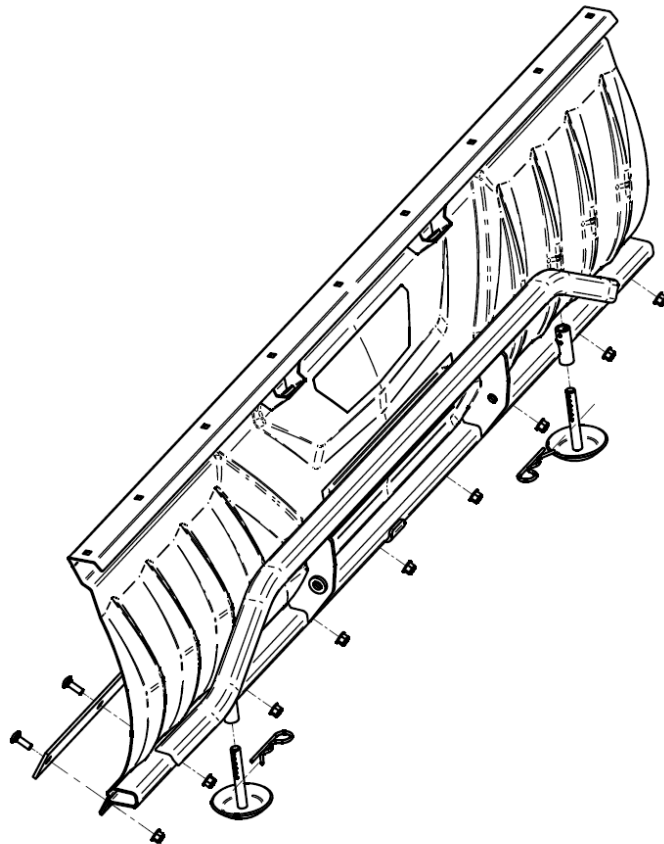

## Kit Contents:

Item	Qty	Part Description	Part Number
1	9	Carriage Bolt, Zinc Plated, M8-1.25 X 25mm LG	-
2	2	Hairpin Cotter Pin, Zinc Plated, 82mm LG, 4mm wire dia.	31-1156
3	3	Hex Flange Nylon Nut, Zinc Plated, M8-1.25	-
4	1	Plow Shoe Kit	31-1155
5	1	60" Welded Steel Blade	-
6	1	Wear Bar Kit, 60"	31-1160
7	1	Top Decal (not shown)	-
8	1	Instruction Guide (not shown)	-

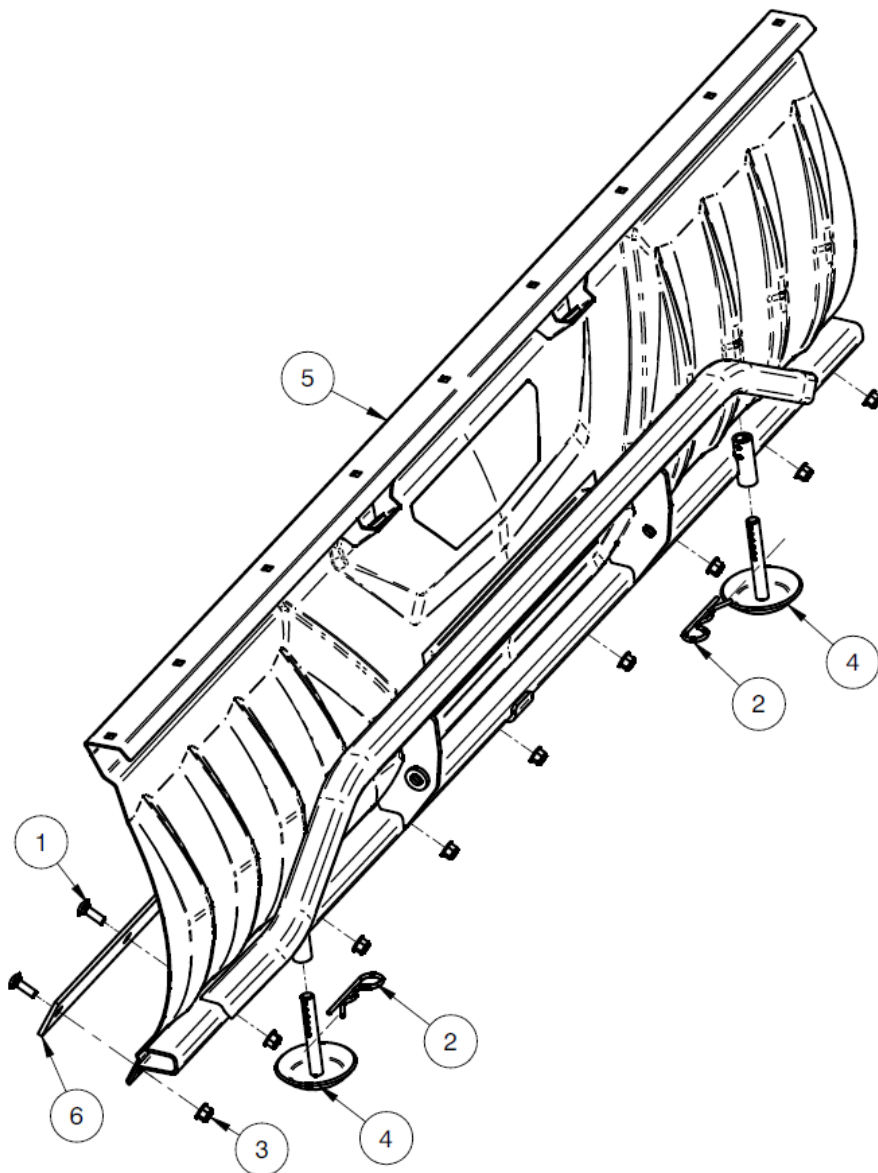

## BEFORE YOU BEGIN:

- Your Kolpin accessory is exclusively designed for your vehicle.
- Please read and understand all instructions.
- Verify all parts and tools are accounted for.
- To ensure a satisfactory installation, follow all steps correctly and in the sequence described.
- Keep these instructions for future reference or for informational requests.
- To facilitate installation, make sure that your vehicle is clean and free of debris.
- All directions referring to right and left are when the rider is sitting on the machine

## TOOLS REQUIRED:

- 13mm Wrench
- 13mm Socket

## APPROXIMATE ASSEMBLY TIME: 15 minutes

Note: The High Rise Blade kit comes fully assembled from factory.

## SPARE KIT INFORMATION:

SPARE KITS		Wear bar kit	Skid shoe kit	R-pin kit	Wear bar bolt kit
Item	Description				
1	M8-1.25 x 25 mm carriage bolt	9x			11x
2	R-pin		2x	2x	
3	M8-1.25 Nylon nut	9x			11x
4	Skid shoe		2x		
5	Blade (60")				
6	Wear bar	1x			

## OPERATING INSTRUCTIONS

Congratulations! You've just purchased one of the industry's top plow system component. The High Rise Plow Blade works great for all types of plowing. With proper care and maintenance, your plow blade will last for many years! The 60" (152 cm) Blade Assembly allows for quality snow moving capacity and snow roll-over characteristics. Additionally, this blade will handle light to medium-duty summer landscape work.

<b>NOTICE</b>
<b>Plow operation requires additional components for operation: High Rise Plow Push Frame, Winch Kit, Mid-Body ATV Plow Mount *</b>
<i>*These components may be specific to your vehicle.</i>



Please read and understand all assembly instructions, notices and warnings before assembling and operating your plow system.

### Follow these guidelines to ensure satisfactory operation:

- Read this manual and your ATV operators manual before use.
- Periodically check for wear and tightness of all fasteners. Replace or re-torque fasteners as necessary.
- Before first use, set plow in the furthest right or left angled position to check for clearance between the plow and front tires.
- Operate with extreme caution on slopes and rough terrain. Be familiar with the area before you plow.
- Be aware of immovable objects that could be hidden in the area you are plowing.
- To avoid damage when pushing snow into a pile, reverse direction before raising the plow blade.
- Do not ram the plow blade into piles of snow.
- For best results, set the suspension preload of your ATV to the stiffest setting.
- To reduce steering effort and increase mobility, set the air pressure of your tires to the maximum pressure specification.
- The plow skids are adjustable. General skid setting is even with the plow wear bar bottom edge, higher settings reduce the chance of rocks and gravel from being collected.
- To increase traction during plow operation, operators can try: Securing weight to the ATV for additional tire downforce, reducing tire air pressure, or installing tire chains.

## SAFETY INFORMATION

Our plow systems were designed with your safety in mind. Please read and understand all Cautions, Notices and Warnings in this manual before you begin. In order to protect you and your ATV, certain parts of the plow system and/or hardware are designed to fail when the equipment is over-stressed.

 <b>DANGER</b> 
<b>TO AVOID SERIOUS INJURY OR DEATH:</b>
1. <b>DO NOT EXCEED 5 MPH (8 KMH) WITH BLADE INSTALLED.</b>
2. <b>OPERATE WITH EXTREME CAUTION ON SLOPES, STEEP GRADES, AND ROUGH TERRAIN.</b>
3. <b>ALLOW NO RIDERS ON BLADE OR ATV WHILE MOVING OR STATIONARY.</b>
4. <b>KEEP BYSTANDERS AWAY FROM THE BLADE OR ATV WHILE MOVING OR STATIONARY.</b>
5. <b>WHEN PUSHING HEAVY MATERIAL, DIRECTION CONTROL MAY BECOME DIFFICULT.</b>
6. <b>BEFORE ADJUSTING BLADE: STOP ATV ENGINE; SET AND LOCK BRAKES; RAISE AND LOCK BLADE IN UP POSITION. DO NOT ATTEMPT TO RAISE BLADE BY HAND; USE THE LIFT MECHANISM ONLY.</b>
7. <b>LOWER BLADE TO DOWN POSITION WHEN BLADE AND ATV ARE NOT IN USE.</b>
8. <b>READ BLADE'S INSTRUCTION SHEETS AND ATV OWNER MANUAL.</b>





## One Year Limited Warranty

For the period of one (1) year from the purchase date, Kolpin will replace for the original purchaser, free of charge, any part or parts found upon examination by Kolpin to be defective in material, workmanship, or both.

All transportation costs incurred submitting product to Kolpin for warranty consideration must be borne by the purchaser. If Kolpin determines that the product must be returned to the factory for credit, please call 1-877-956-5746 for a Return Merchandise Authorization (RMA) number and shipping instructions.

This warranty does not apply to parts that have been damaged by accident, alteration, abuse, improper maintenance, normal wear, or other causes beyond the manufacturer's control. In order to protect you and your ATV, certain parts of the plow system and/or hardware are designed to fail when the equipment is over-stressed. Parts that are lost due to loosening and improper maintenance are not covered under warranty.

Peripheral products such as engines, electric motors, and actuators may carry an original manufacturer's warranty. Most hardware is general in nature and is easily obtained locally. Be sure to replace with minimum grade 5 specification.

**Kolpin Outdoors, Inc.**  
**Telephone: (763)-478-5800**  
**Toll Free: (877)-956-5746**  
**Fax Number: (800)-245-7569**  
**[www.kolpinpowersports.com](http://www.kolpinpowersports.com)**  
**[customerservice@kolpin.com](mailto:customerservice@kolpin.com)**



# POLY BLADE KIT

P/N 31-2060 / 31-2072 / 31-2084

ASSEMBLY / SPARE PARTS MANUAL

## Application

PLOW PUSH FRAME NO. 33-0000, 33-0070 or 35-0070

Before you begin, please read these instructions and check to be sure all parts and tools are accounted for. The following instructions contain details required to install and service the contents of this kit.

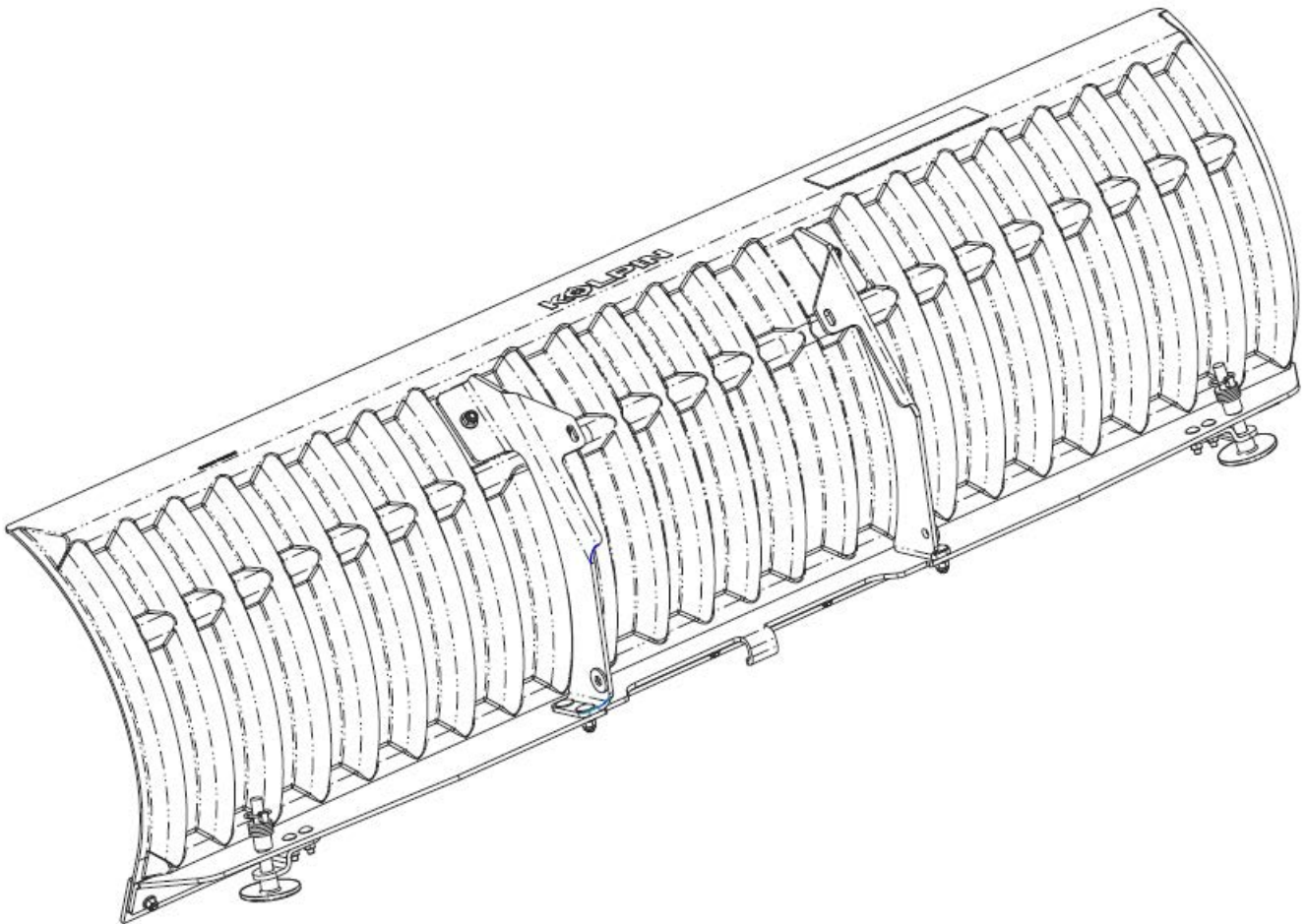

# OPERATING INSTRUCTIONS

Congratulations! You've just purchased one of the industry's top plow system component. The Poly Blade works great for all types of plowing. With proper care and maintenance, your plow blade will last for many years! The 60" (152 cm) / 72" (183 cm) / 84" (213 cm) Blade Assembly allows for quality snow moving capacity and snow roll-over characteristics. Additionally, this blade will handle light to medium-duty summer landscape work.

<b>NOTICE</b>
<b>Plow operation requires additional components for operation: <i>Kolpin Plow Push Frame, Winch Kit, ATV / UTV Plow Mount</i> *</b>
<i>*These components may be specific to your vehicle.</i>



Please read and understand all assembly instructions, notices and warnings before assembling and operating your plow system.

## Follow these guidelines to ensure satisfactory operation:

- Read this manual and your ATV/ UTV operators manual before use.
- Periodically check for wear and tightness of all fasteners. Replace or re-torque fasteners as necessary.
- Before first use, set plow in the furthest right or left angled position to check for clearance between the plow and front tires.
- Operate with extreme caution on slopes and rough terrain. Be familiar with the area before you plow.
- Be aware of immovable objects that could be hidden in the area you are plowing.
- To avoid damage when pushing snow into a pile, reverse direction before raising the plow blade.
- Do not ram the plow blade into piles of snow.
- For best results, set the suspension preload of your ATV/ UTV to the stiffest setting.
- To reduce steering effort and increase mobility, set the air pressure of your tires to the maximum pressure specification.
- The plow skids are adjustable. General skid setting is even with the plow wear bar bottom edge, higher settings reduce the chance of rocks and gravel from being collected.
- To increase traction during plow operation, operators can try: Securing weight to the ATV/ UTV for additional tire downforce, reducing tire air pressure, or installing tire chains.

# SAFETY INFORMATION

Our plow systems were designed with your safety in mind. Please read and understand all Cautions, Notices and Warnings in this manual before you begin. In order to protect you and your ATV, certain parts of the plow system and/or hardware are designed to fail when the equipment is over-stressed.

 <b>WARNING</b> 
<b>TO AVOID SERIOUS INJURY OR DEATH:</b>
1. <b>DO NOT EXCEED 5 MPH (8 KMH) WITH BLADE INSTALLED</b>
2. <b>OPERATE WITH EXTREME CAUTION ON SLOPES, STEEP GRADES, AND ROUGH TERRAIN</b>
3. <b>ALLOW NO RIDERS ON BLADE OR ATV WHILE MOVING OR STATIONARY</b>
4. <b>KEEP BYSTANDERS AWAY FROM THE BLADE OR ATV WHILE MOVING OR STATIONARY</b>
5. <b>WHEN PUSHING HEAVY MATERIAL, DIRECTION CONTROL MAY BECOME DIFFICULT</b>
6. <b>BEFORE ADJUSTING BLADE: STOP ATV ENGINE; SET AND LOCK BRAKES; RAISE AND LOCK BLADE</b>
7. <b>LOWER BLADE TO DOWN POSITION WHEN BLADE AND ATV ARE NOT IN USE</b>
8. <b>READ BLADE INSTRUCTION SHEETS AND ATV OWNER'S MANUAL</b>

# 31-2060 / 31-2072 / 31-2084 Kit Contents:

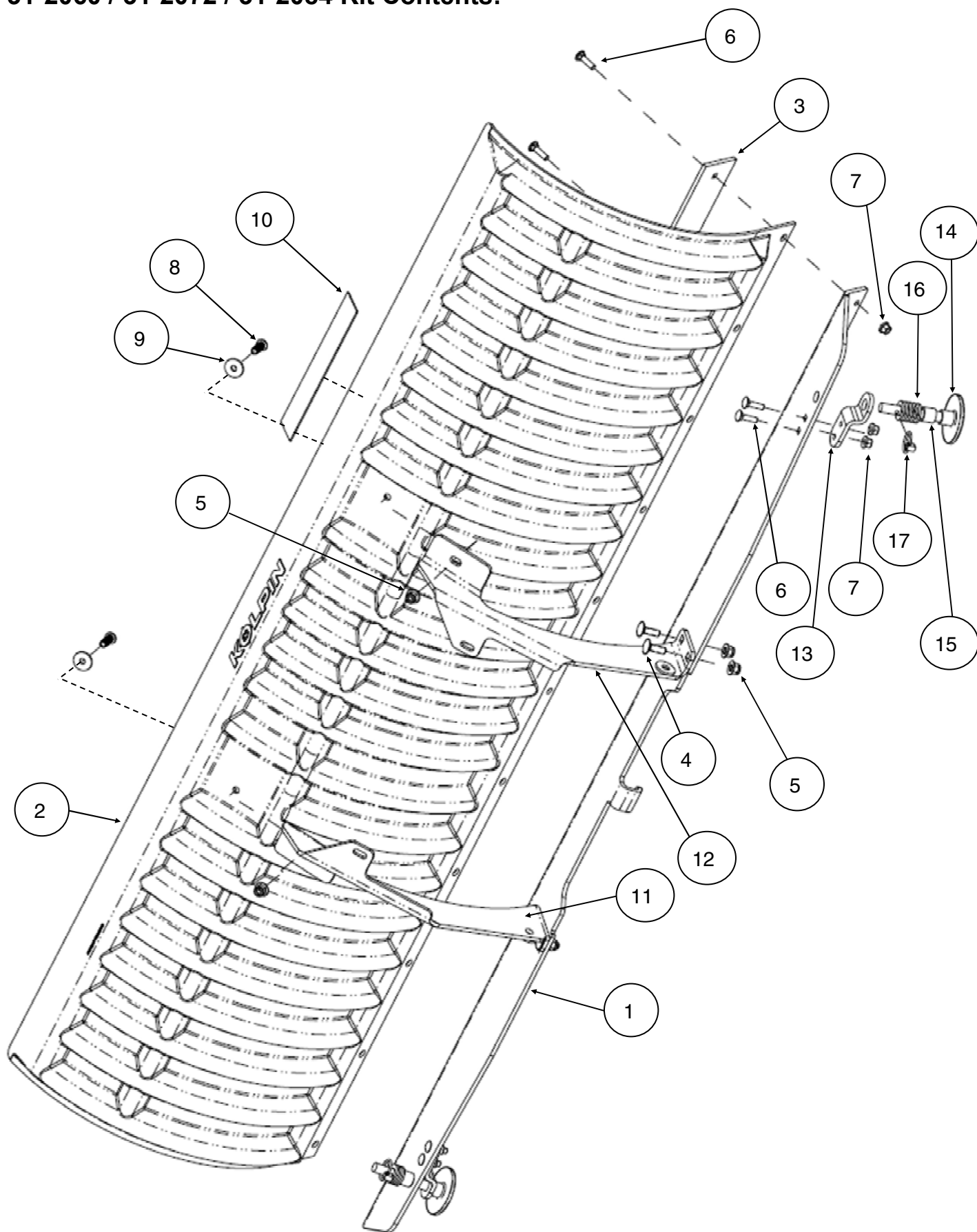

### 31-2060 / 31-2072 / 31-2084 Kit Contents (continued):

Item	Qty	Part Description	Part Number
1	1	60" Rear Angle Blade Support	-
1	1	72" Rear Angle Blade Support	-
1	1	84" Rear Angle Blade Support	-
2	1	60" Plastic Moldboard Blade	31-2060-CP01
2	1	72" Plastic Moldboard Blade	31-2072-CP01
2	1	84" Plastic Moldboard Blade	31-2084-CP01
3	1	60" Wear Bar, Double Sided	31-2160
3	1	72" Wear Bar, Double Sided	31-2172
3	1	84" Wear Bar, Double Sided	31-2184
4	4	Carriage Bolt, Zinc Plated, M10-1.50 X 30mm LG	-
5	6	Hex Flange Lock Nut, Zinc Plated, M10-1.50	-
6	13	(60" kit) Carriage Bolt, Zinc Plated, M8-1.25 X 30mm LG	-
6	15	(72" kit) Carriage Bolt, Zinc Plated, M8-1.25 X 30mm LG	-
6	17	(84" kit) Carriage Bolt, Zinc Plated, M8-1.25 X 30mm LG	-
7	13	(60" kit) Hex Flange Lock Nut, Zinc Plated, M8-1.25	-
7	15	(72" kit) Hex Flange Lock Nut, Zinc Plated, M8-1.25	-
7	17	(84" kit) Hex Flange Lock Nut, Zinc Plated, M8-1.25	-
8	2	Button Head Cap Screw, Zinc Plated, M10-1.5 X 30mm LG	-
9	2	Fender Washer, Zinc Plated, M10	-
10	1	Top Warning Decal	31-2072-CP03
11	1	Vertical Rib Blade Support, LH	-
12	1	Vertical Rib Blade Support, RH	-
13	2	Skid Bracket	-
14	2	Skid Shoe	PUR1467
15	4	Spacer	-
16	10	Flat Washer, Zinc Plated, M18	-
17	2	Lynch Quick Pin, Zinc Plated, 4.76mm Dia x 38mm LG	PUR1359
18	1	Instruction Guide (not shown)	-

## BEFORE YOU BEGIN:

- Your Kolpin accessory is exclusively designed for your vehicle.
- Please read and understand all instructions.
- Verify all parts and tools are accounted for.
- To ensure a satisfactory installation, follow all steps correctly and in the sequence described.
- Keep these instructions for future reference or for informational requests.
- To facilitate installation, make sure that your vehicle is clean and free of debris.
- All directions referring to right and left are when the rider is sitting on the machine.

## TOOLS REQUIRED:

- Basic Metric Wrench and Socket Set
- Torque Wrench

## APPROXIMATE ASSEMBLY TIME: 15 minutes

Note: If any hardware is missing, do not return to the store. Call us to help, Toll Free 1-877-956-5746.

## SPARE KIT INFORMATION:

SPARE KITS		Wear bar kit P/N 31-2160 / 31-2172 / 31- 2184	Skid shoe kit P/N 31-2155	Hardware kit P/N 31-2073	Wear bar bolt kit P/N 12-0010
Item	Description				
3	Wear Bar, Double Sided	1x / 1x / 1x			
4	Carriage Bolt, Zinc Plated, M10-1.50 X 30mm LG			4x	
5	Hex Flange Lock Nut, Zinc Plated, M10-1.50			6x	
6	Carriage Bolt, Zinc Plated, M8-1.25 X 30mm LG	9x / 11x / 13x		15x	11x
7	Hex Flange Lock Nut, Zinc Plated, M8-1.25	9x / 11x / 13x		15x	11x
8	Button Head Cap Screw, Zinc Plated, M10-1.5 X 30mm LG			2x	
9	Fender Washer, Zinc Plated, M10			2x	
14	Skid Shoe		2x		
15	Spacer		4x	4x	
16	Flat Washer, M18		10x	10x	
17	Lynch Quick Pin, Zinc Plated, 4.76mm Dia x 38mm LG		2x	2x	

## Spare Kit Notes:

- Spare kits may contain extra hardware that is used for other mount kits. Extra hardware can be discarded.

## USE AND CARE INFORMATION:

Note: The wear bar cutting edge is double-sided, so when bottom side wears thin, flip the bar over and use the top side for extended cutting edge life.

## ASSEMBLY INSTRUCTIONS:

1. Attach vertical rib blade supports (items #11 and #12) to the rear angle blade support (item #1) as shown. Use M10 carriage screws (item #4) and fasten with M10 locknut (item #5). (See illustration 1-1). **Note, do not fully tighten at this time.**
2. Attach the assembled support to the moldboard blade (item #2) at the upper locations using fender washers (item #9) and M10 button cap screws (item #8) as shown. Fasten using M10 locknuts (item #5). **Note, do not fully tighten at this time.**

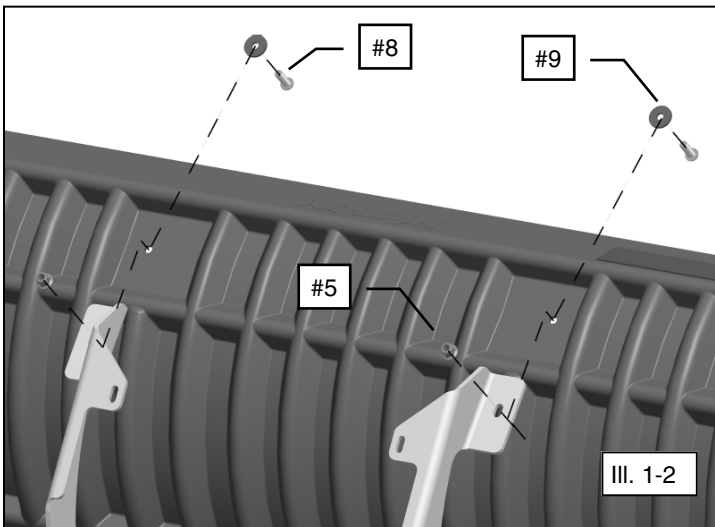
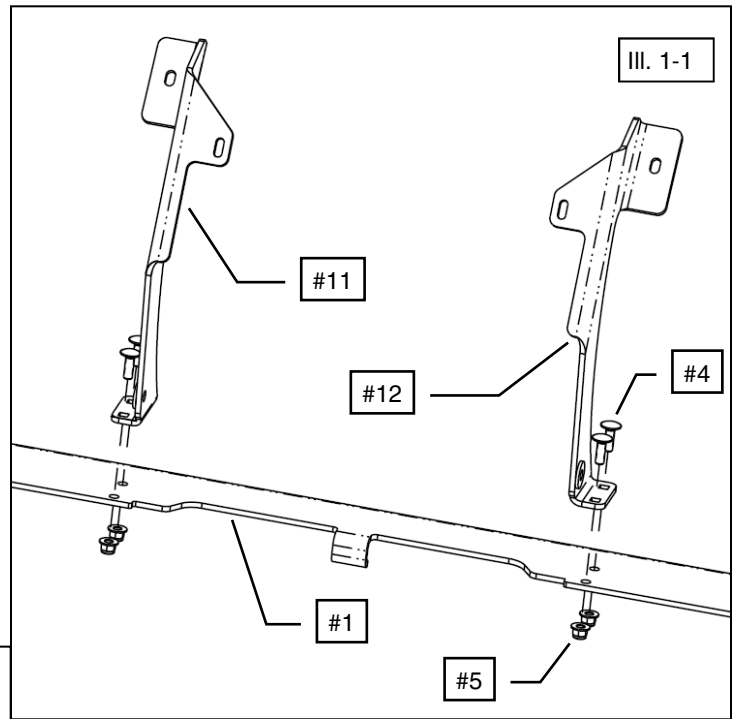

3. Place the blade assembly on its back and attach the wear bar (item #3) to the blade and support assembly using the M8 carriage bolts (item #10) as shown. Fasten using M8 locknuts (item #7). (See illustration 1-3). **Note, start with the middle wear bar hole first. The middle hole in the plastic moldboard is smaller to help index/center the blade.**
4. Torque M8 fasteners to specification.

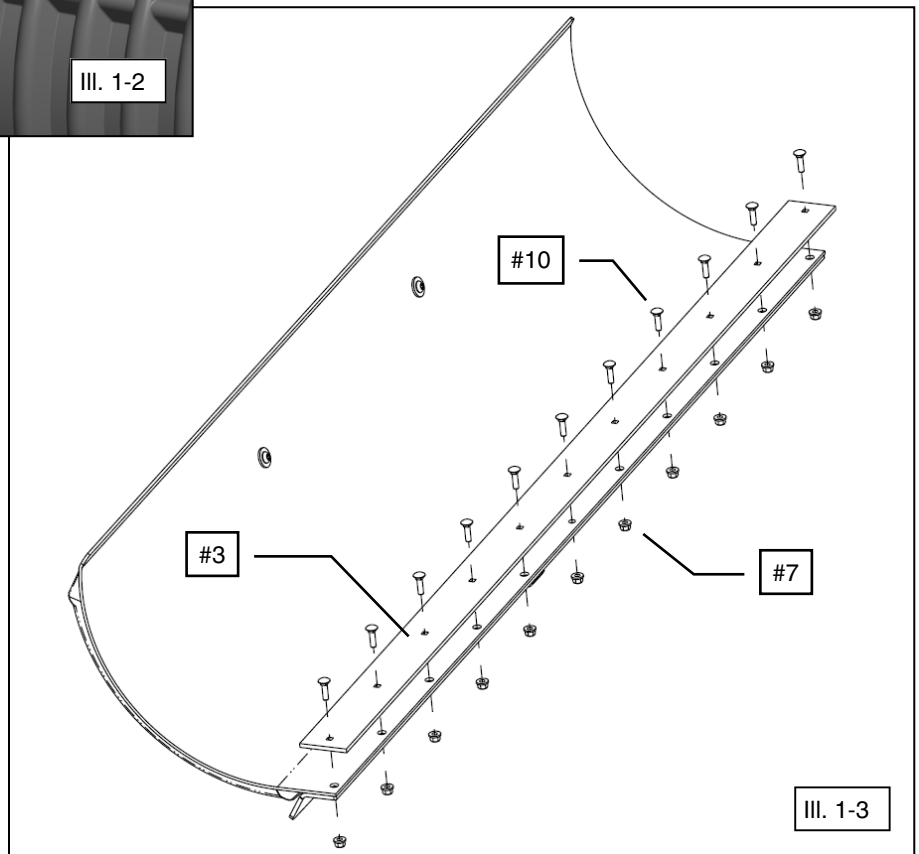

<b>8MM FASTENER TORQUE:</b> 17 ft. lbs. (23 Nm)

## ASSEMBLY INSTRUCTIONS (continued):

5. Torque the lower vertical support rib fasteners (items #4 and #5) to specification below.

 = T
<b>LOWER SUPPORT RIB FASTENER TORQUE:</b> 30 ft. lbs. (41 Nm)

6. Torque the lower vertical support rib fasteners (items #8 and #5) to specification below.

 = T
<b>UPPER SUPPORT RIB FASTENER TORQUE:</b> 17 ft. lbs. (23 Nm)

7. Attached skid brackets (item #13) to each end of the rear angle support (item #1) using M8 carriage screws (item #6) as shown. Fasten using M8 locknuts (item #7). (See illustration 1-4).

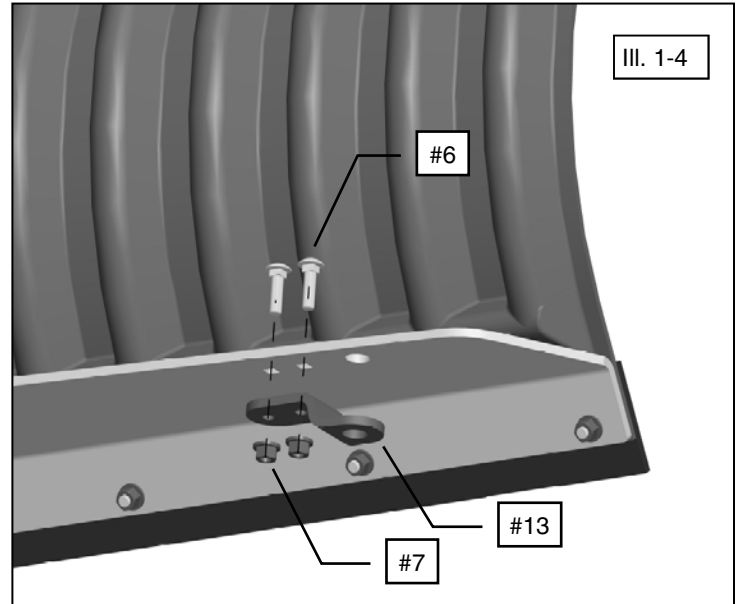

8. Torque to M8 specification.

 = T
<b>8MM FASTENER TORQUE:</b> 17 ft. lbs. (23 Nm)

9. Assemble and install skid components (items #14, #15 and #16) as shown. Fasten using quick pins (items #17). (See illustration 1-5). **Note, initial setting of skid height depends on the terrain. Set the skids even with the wear bar cutting edge for level surfaces such as concrete or asphalt. For irregular surfaces, lower the skids to raise the wear bar cutting edge.**

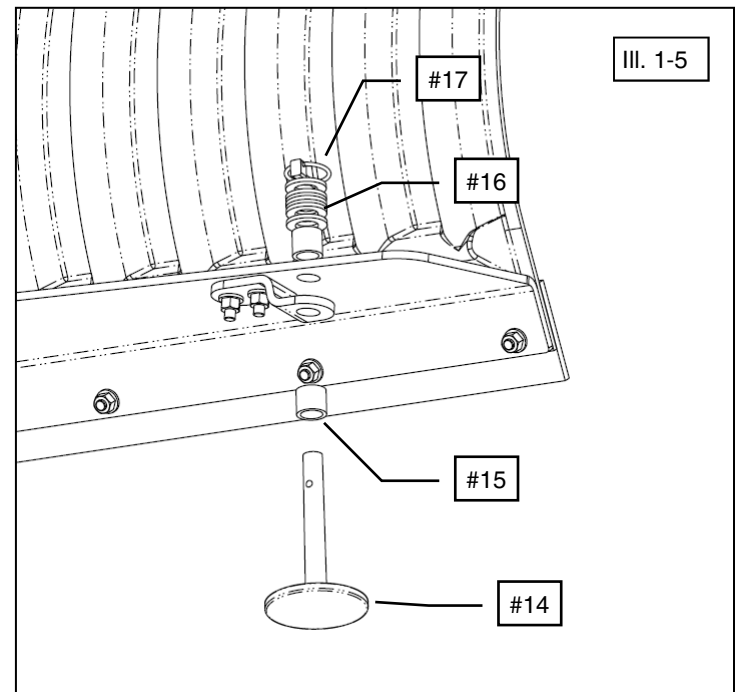





## **Two Year Limited Warranty**

For the period of two (2) years from the purchase date, Kolpin will replace for the original purchaser, free of charge, any part or parts found upon examination by Kolpin to be defective in material, workmanship, or both.

All transportation costs incurred submitting product to Kolpin for warranty consideration must be borne by the purchaser. If Kolpin determines that the product must be returned to the factory for credit, please call 1-877-956-5746 for a Return Merchandise Authorization (RMA) number and shipping instructions.

This warranty does not apply to parts that have been damaged by accident, alteration, abuse, improper maintenance, normal wear, or other causes beyond the manufacturer's control. In order to protect you and your ATV, certain parts of the plow system and/or hardware are designed to fail when the equipment is over-stressed. Parts that are lost due to loosening and improper maintenance are not covered under warranty. This warranty does not cover removal or reinstallation labor fees of the plow system and related components.

Peripheral products such as engines, electric motors, and actuators may carry an original manufacturer's warranty. Most hardware is general in nature and is easily obtained locally. Be sure to replace with minimum metric class 8.8 specification.

**Kolpin Outdoors, Inc.**

**Telephone: (763)-478-5800**

**Toll Free: (877)-956-5746**

**Fax Number: (800)-245-7569**

**[www.kolpin.com](http://www.kolpin.com)**

**Email: [customerservice@kolpin.com](mailto:customerservice@kolpin.com)**



# HIGH RISE BLADE (66") KIT

P/N 31-0066

## ASSEMBLY / SPARE PARTS MANUAL

### Application

PLOW PUSH FRAME NO. 33-0000, 33-0070, 34-0000 or 34-0070

Before you begin, please read these instructions and check to be sure all parts and tools are accounted for. The following instructions contain details required to install and service the contents of this kit.

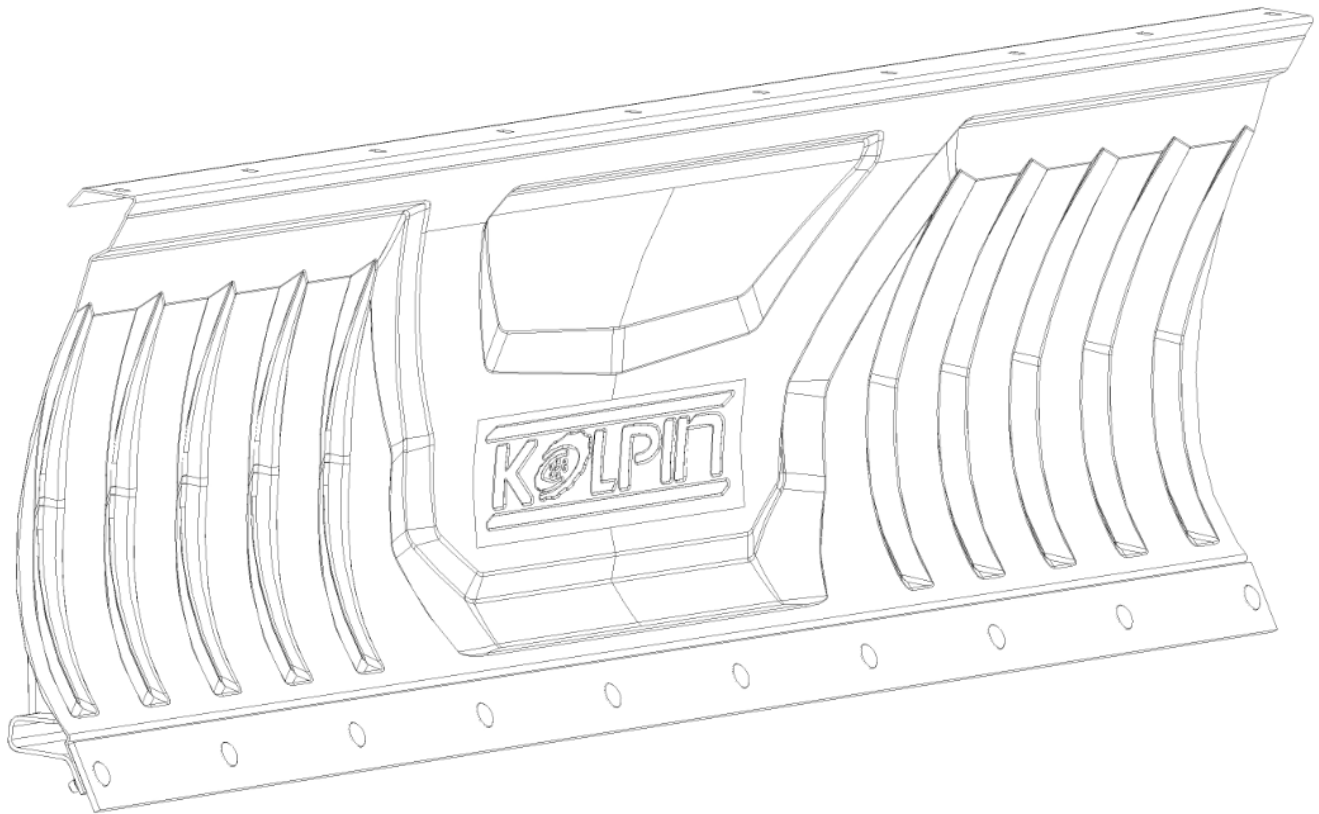

## Kit Contents:

Item	Qty	Part Description	Part Number
1	10	Carriage Bolt, Zinc Plated, M8-1.25 X 25mm LG	-
2	2	Hairpin Cotter Pin, Zinc Plated, 82mm LG, 4mm wire dia.	31-1156
3	10	Hex Flange Nylon Nut, Zinc Plated, M8-1.25	-
4	1	Plow Shoe Kit	31-1155
5	1	66" Welded Steel Blade	-
6	1	Wear Bar Kit, 66"	31-1166
7	1	Top Decal	-
8	1	Instruction Guide (not shown)	-

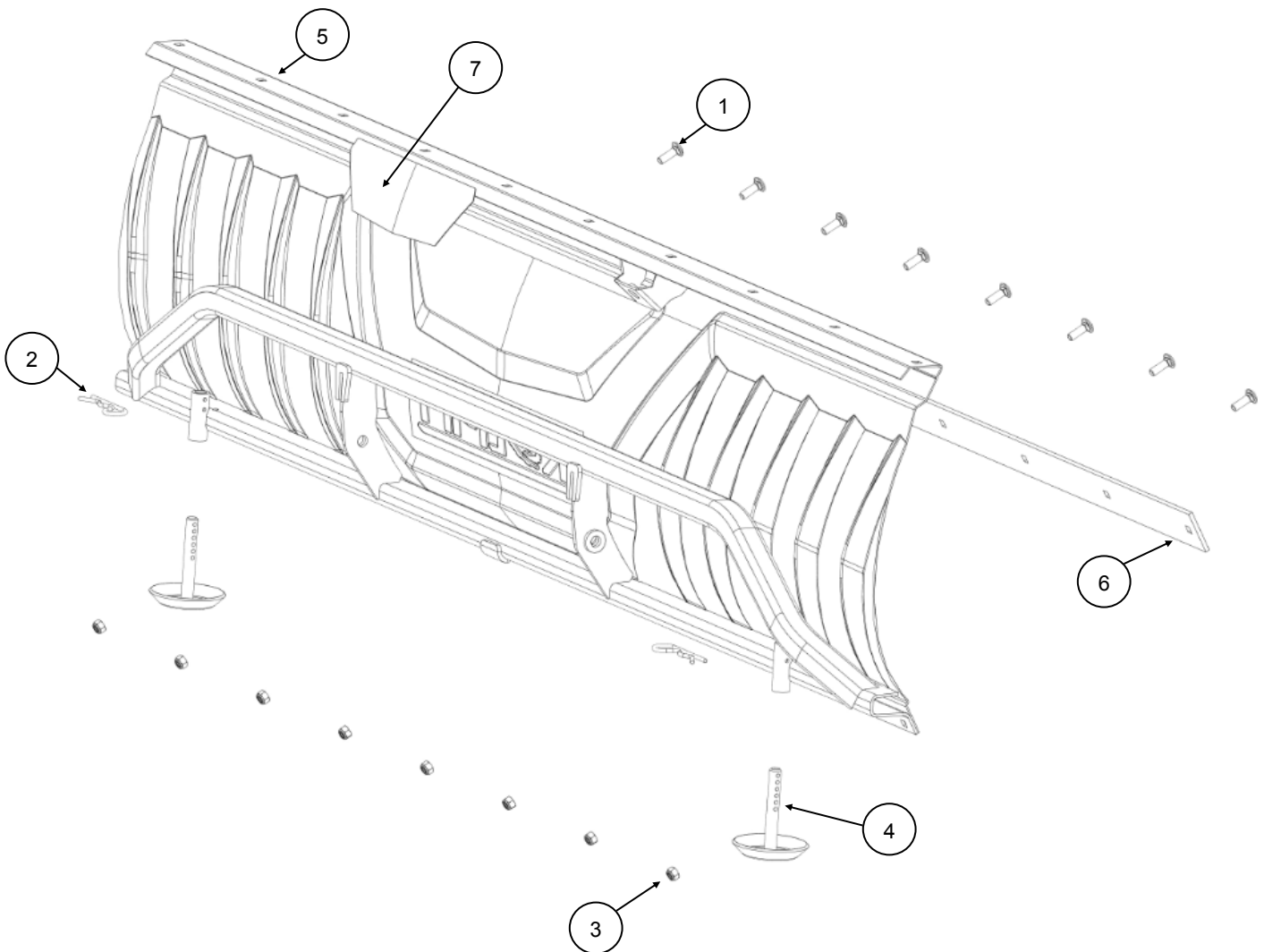

## BEFORE YOU BEGIN:

- Your Kolpin accessory is exclusively designed for your vehicle.
- Please read and understand all instructions.
- Verify all parts and tools are accounted for.
- To ensure a satisfactory installation, follow all steps correctly and in the sequence described.
- Keep these instructions for future reference or for informational requests.
- To facilitate installation, make sure that your vehicle is clean and free of debris.
- All directions referring to right and left are when the rider is sitting on the machine

## TOOLS REQUIRED:

- 13mm Wrench
- 13mm Socket

## APPROXIMATE ASSEMBLY TIME: 15 minutes

Note: The High Rise Blade kit comes fully assembled from factory.

## SPARE KIT INFORMATION:

SPARE KITS		Wear bar kit	Skid shoe kit	R-pin kit	Wear bar bolt kit
Item	Description	P/N 31-1166	P/N 31-1155	P/N 31-1156	P/N 12-0010
1	M8-1.25 x 25 mm carriage bolt	10x			11x
2	R-pin		2x	2x	
3	M8-1.25 Nylon nut	10x			11x
4	Skid shoe		2x		
5	Blade (66")				
6	Wear bar	1x			

## OPERATING INSTRUCTIONS

Congratulations! You've just purchased one of the industry's top plow system component. The High Rise Plow Blade works great for all types of plowing. With proper care and maintenance, your plow blade will last for many years! The 66" (168 cm) Blade Assembly allows for quality snow moving capacity and snow roll-over characteristics. Additionally, this blade will handle light to medium-duty summer landscape work.

NOTICE
<p><b>Plow operation requires additional components for operation: <i>Kolpin Plow Push Frame, High Rise Plow Push Frame, Winch Kit, Mid-Body ATV / UTV Plow Mount *</i></b></p> <p><i>*These components may be specific to your vehicle.</i></p>



Please read and understand all assembly instructions, notices and warnings before assembling and operating your plow system.

### Follow these guidelines to ensure satisfactory operation:

- Read this manual and your ATV/ UTV operators manual before use.
- Periodically check for wear and tightness of all fasteners. Replace or re-torque fasteners as necessary.
- Before first use, set plow in the furthest right or left angled position to check for clearance between the plow and front tires.
- Operate with extreme caution on slopes and rough terrain. Be familiar with the area before you plow.
- Be aware of immovable objects that could be hidden in the area you are plowing.
- To avoid damage when pushing snow into a pile, reverse direction before raising the plow blade.
- Do not ram the plow blade into piles of snow.
- For best results, set the suspension preload of your ATV/ UTV to the stiffest setting.
- To reduce steering effort and increase mobility, set the air pressure of your tires to the maximum pressure specification.
- The plow skids are adjustable. General skid setting is even with the plow wear bar bottom edge, higher settings reduce the chance of rocks and gravel from being collected.
- To increase traction during plow operation, operators can try: Securing weight to the ATV/ UTV for additional tire downforce, reducing tire air pressure, or installing tire chains.

## SAFETY INFORMATION

Our plow systems were designed with your safety in mind. Please read and understand all Cautions, Notices and Warnings in this manual before you begin. In order to protect you and your ATV, certain parts of the plow system and/or hardware are designed to fail when the equipment is over-stressed.

 <b>DANGER</b> 
<p><b>TO AVOID SERIOUS INJURY OR DEATH:</b></p> <ol style="list-style-type: none"><li>1. <b>DO NOT EXCEED 5 MPH (8 KMH) WITH BLADE INSTALLED.</b></li><li>2. <b>OPERATE WITH EXTREME CAUTION ON SLOPES, STEEP GRADES, AND ROUGH TERRAIN.</b></li><li>3. <b>ALLOW NO RIDERS ON BLADE OR ATV WHILE MOVING OR STATIONARY.</b></li><li>4. <b>KEEP BYSTANDERS AWAY FROM THE BLADE OR ATV WHILE MOVING OR STATIONARY.</b></li><li>5. <b>WHEN PUSHING HEAVY MATERIAL, DIRECTION CONTROL MAY BECOME DIFFICULT.</b></li><li>6. <b>BEFORE ADJUSTING BLADE: STOP ATV ENGINE; SET AND LOCK BRAKES; RAISE AND LOCK BLADE IN UP POSITION. DO NOT ATTEMPT TO RAISE BLADE BY HAND; USE THE LIFT MECHANISM ONLY.</b></li><li>7. <b>LOWER BLADE TO DOWN POSITION WHEN BLADE AND ATV ARE NOT IN USE.</b></li><li>8. <b>READ BLADE'S INSTRUCTION SHEETS AND ATV OWNER MANUAL.</b></li></ol>



## One Year Limited Warranty

For the period of one (1) year from the purchase date, Kolpin will replace for the original purchaser, free of charge, any part or parts found upon examination by Kolpin to be defective in material, workmanship, or both.

All transportation costs incurred submitting product to Kolpin for warranty consideration must be borne by the purchaser. If Kolpin determines that the product must be returned to the factory for credit, please call 1-877-956-5746 for a Return Merchandise Authorization (RMA) number and shipping instructions.

This warranty does not apply to parts that have been damaged by accident, alteration, abuse, improper maintenance, normal wear, or other causes beyond the manufacturer's control. In order to protect you and your ATV, certain parts of the plow system and/or hardware are designed to fail when the equipment is over-stressed. Parts that are lost due to loosening and improper maintenance are not covered under warranty.

Peripheral products such as engines, electric motors, and actuators may carry an original manufacturer's warranty. Most hardware is general in nature and is easily obtained locally. Be sure to replace with minimum grade 5 specification.

**Kolpin Outdoors, Inc.**

**Telephone: (763)-478-5800**

**Toll Free: (877)-956-5746**

**Fax Number: (800)-245-7569**

**[www.kolpinpowersports.com](http://www.kolpinpowersports.com)**

**[customerservice@kolpin.com](mailto:customerservice@kolpin.com)**



# STEEL SNOW PLOW BLADE (72") KIT

P/N 31-0072

## ASSEMBLY / SPARE PARTS MANUAL

### Application

PLOW PUSH FRAME NO. 33-0000, 33-0070, 34-0000 or 34-0070

Before you begin, please read these instructions and check to be sure all parts and tools are accounted for. The following instructions contain details required to install and service the contents of this kit.

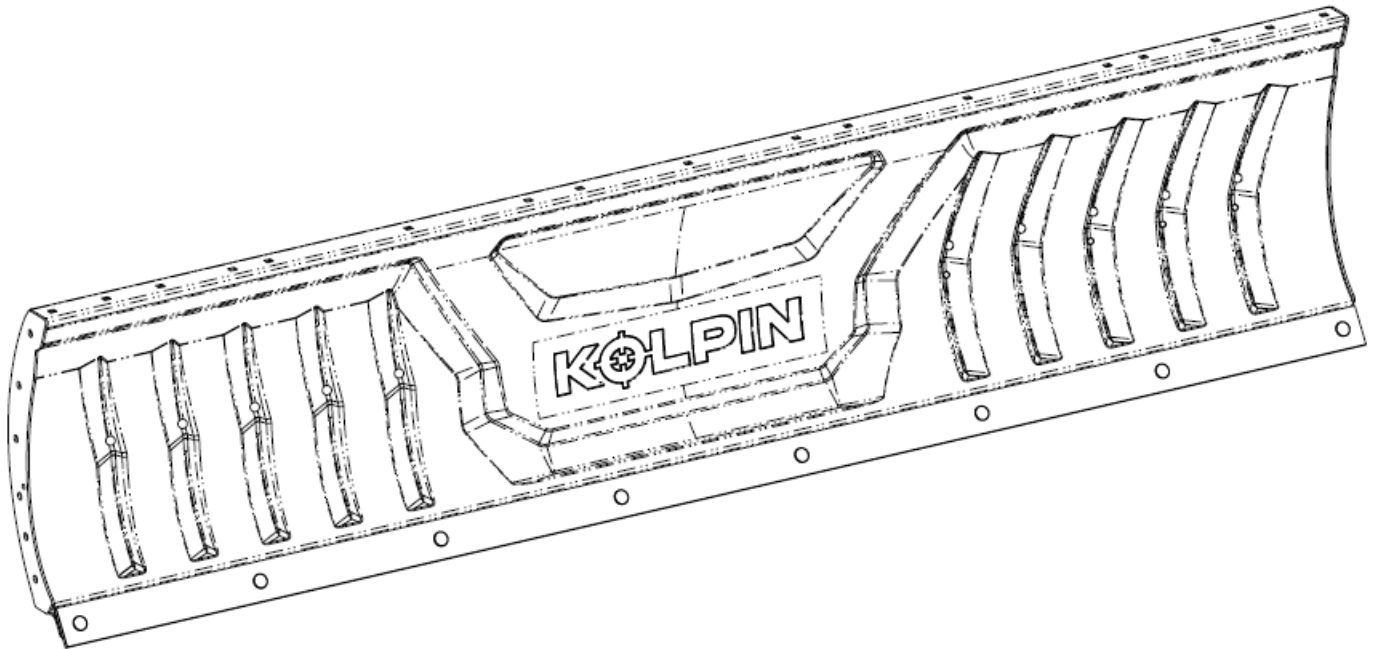

## Kit Contents:

Item	Qty	Part Description	Part Number
1	8	Carriage Bolt, Zinc Plated, M8-1.25 X 25mm LG	-
2	2	Hairpin Cotter Pin, Zinc Plated, 82mm LG, 4mm wire dia.	31-1156
3	8	Hex Flange Lock Nut, Zinc Plated, M8-1.25	-
4	1	Plow Shoe Kit	31-1255
5	1	72" Welded Steel Blade	-
6	1	Wear Bar Kit, 72"	31-1172
7	1	Top Decal	-
8	1	Instruction Guide (not shown)	-

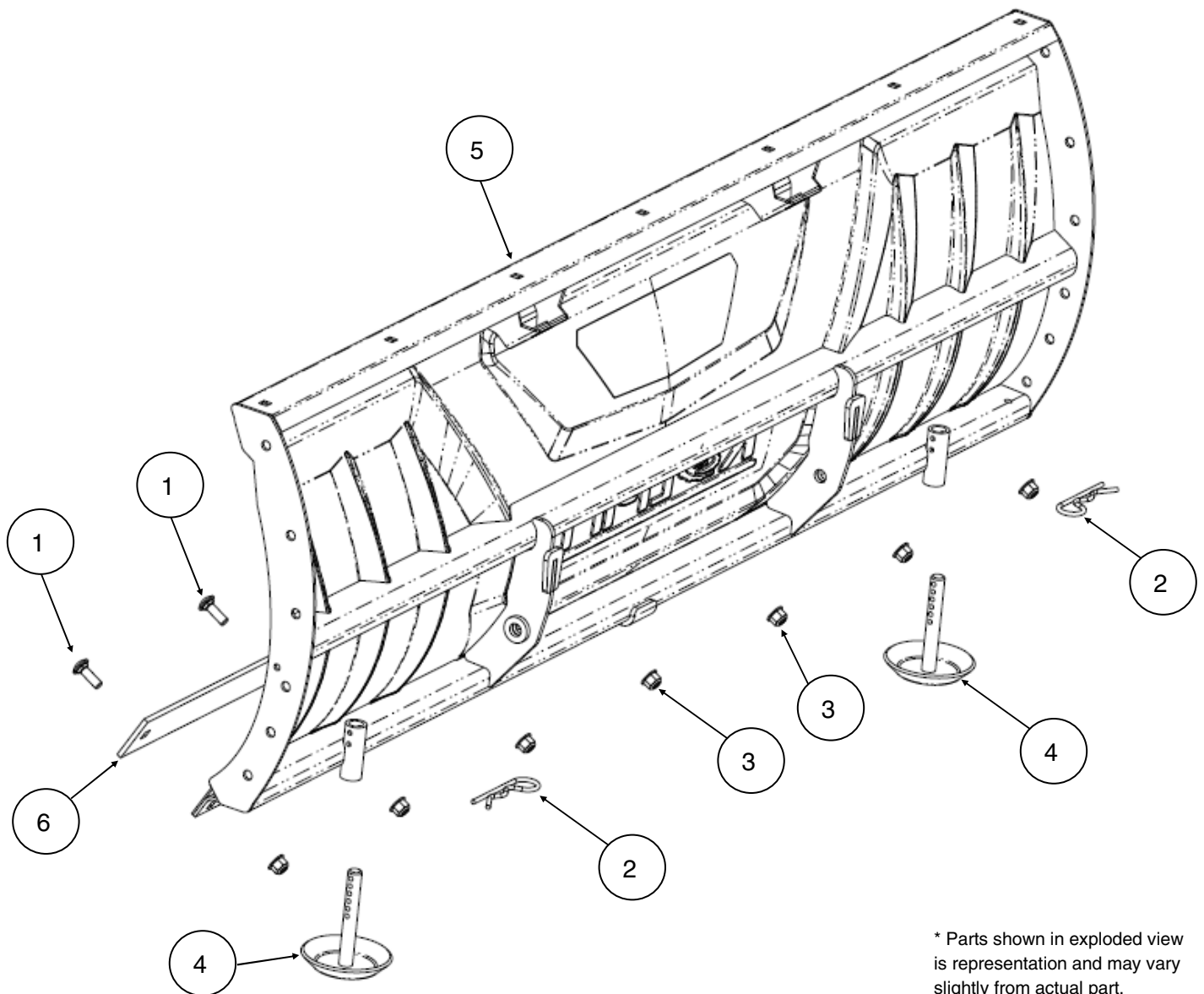

\* Parts shown in exploded view is representation and may vary slightly from actual part.



## BEFORE YOU BEGIN:

- Your Kolpin accessory is exclusively designed for your vehicle.
- Please read and understand all instructions.
- Verify all parts and tools are accounted for.
- To ensure a satisfactory installation, follow all steps correctly and in the sequence described.
- Keep these instructions for future reference or for informational requests.
- To facilitate installation, make sure that your vehicle is clean and free of debris.
- All directions referring to right and left are when the rider is sitting on the machine.

## TOOLS REQUIRED:

- 13mm Wrench
- 13mm Socket

## APPROXIMATE ASSEMBLY TIME: 15 minutes

Note: The Kolpin Steel Snow Plow Blade kit comes fully assembled from factory.

## SPARE KIT INFORMATION:

SPARE KITS		Std Wear bar kit PN 31-1172	Skid shoe kit PN 31-1255	R-pin kit PN 31-1156	Wear bar bolt kit PN 12-0010
Item	Description				
1	M8-1.25 x 25 mm carriage bolt	8x			11x
2	R-pin		2x	2x	
3	M8-1.25 Flange Locknut	8x			11x
4	Skid shoe		2x		
5	Blade (72")				
6	72" Std Wear bar	1x			

## USE AND CARE INFORMATION:

Note: The wear bar cutting edge is double-sided, so when bottom side wears thin, flip the bar over and use the top side for extended cutting edge life.

## OPTIONAL ACCESSORIES:

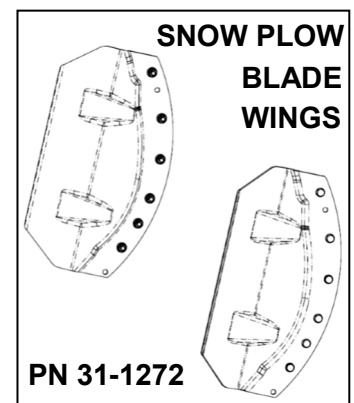
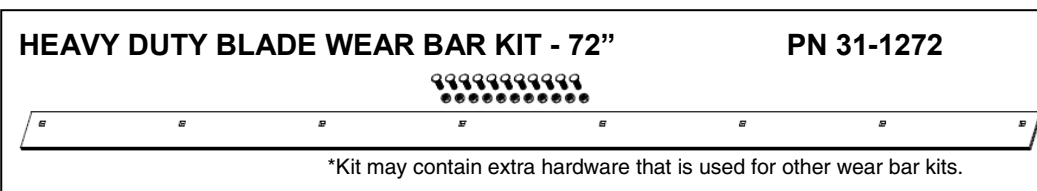

## OPERATING INSTRUCTIONS

Congratulations! You've just purchased one of the industry's top plow system component. The Kolpin Steel Snow Plow Blade works great for all types of plowing. With proper care and maintenance, your plow blade will last for many years! The 72" (183 cm) Blade Assembly allows for quality snow moving capacity and snow roll-over characteristics. Additionally, this blade will handle light to medium-duty summer landscape work.

### NOTICE

**Plow operation requires additional components for operation: *Kolpin Storm Chaser Plow Push Frame, High Rise Plow Push Frame, Winch Kit, Mid-Body ATV / UTV Plow Mount* \***

*\*These components may be specific to your vehicle.*

Please read and understand all assembly instructions, notices and warnings before assembling and operating your plow system.

#### Follow these guidelines to ensure satisfactory operation:

- Read this manual and your ATV/ UTV operators manual before use.
- Periodically check for wear and tightness of all fasteners. Replace or re-torque fasteners as necessary.
- Before first use, set plow in the furthest right or left angled position to check for clearance between the plow and front tires.
- Operate with extreme caution on slopes and rough terrain. Be familiar with the area before you plow.
- Be aware of immovable objects that could be hidden in the area you are plowing.
- To avoid damage when pushing snow into a pile, reverse direction before raising the plow blade.
- Do not ram the plow blade into piles of snow.
- For best results, set the suspension preload of your ATV/ UTV to the stiffest setting.
- To reduce steering effort and increase mobility, set the air pressure of your tires to the maximum pressure specification.
- The plow skids are adjustable. General skid setting is even with the plow wear bar bottom edge, higher settings reduce the chance of rocks and gravel from being collected.
- To increase traction during plow operation, operators can try: Securing weight to the ATV/ UTV for additional tire downforce, reducing tire air pressure, or installing tire chains.

## SAFETY INFORMATION

Our plow systems were designed with your safety in mind. Please read and understand all Cautions, Notices and Warnings in this manual before you begin. In order to protect you and your ATV, certain parts of the plow system and/or hardware are designed to fail when the equipment is over-stressed.

### **WARNING**

#### TO AVOID SERIOUS INJURY OR DEATH:

1. **DO NOT EXCEED 5 MPH (8 KMH) WITH BLADE INSTALLED**
2. **OPERATE WITH EXTREME CAUTION ON SLOPES, STEEP GRADES, AND ROUGH TERRAIN**
3. **ALLOW NO RIDERS ON BLADE OR ATV WHILE MOVING OR STATIONARY**
4. **KEEP BYSTANDERS AWAY FROM THE BLADE OR ATV WHILE MOVING OR STATIONARY**
5. **WHEN PUSHING HEAVY MATERIAL, DIRECTION CONTROL MAY BECOME DIFFICULT**
6. **BEFORE ADJUSTING BLADE: STOP ATV ENGINE; SET AND LOCK BRAKES; RAISE AND LOCK BLADE**
7. **LOWER BLADE TO DOWN POSITION WHEN BLADE AND ATV ARE NOT IN USE**
8. **READ BLADE INSTRUCTION SHEETS AND ATV OWNER'S MANUAL**



## **One Year Limited Warranty**

For the period of one (1) year from the purchase date, Kolpin will replace for the original purchaser, free of charge, any part or parts found upon examination by Kolpin to be defective in material, workmanship, or both.

All transportation costs incurred submitting product to Kolpin for warranty consideration must be borne by the purchaser. If Kolpin determines that the product must be returned to the factory for credit, please call 1-877-956-5746 for a Return Merchandise Authorization (RMA) number and shipping instructions.

This warranty does not apply to parts that have been damaged by accident, alteration, abuse, improper maintenance, normal wear, or other causes beyond the manufacturer's control. In order to protect you and your ATV, certain parts of the plow system and/or hardware are designed to fail when the equipment is over-stressed. Parts that are lost due to loosening and improper maintenance are not covered under warranty. This warranty does not cover removal or reinstallation labor fees of the plow system and related components.

Peripheral products such as engines, electric motors, and actuators may carry an original manufacturer's warranty. Most hardware is general in nature and is easily obtained locally. Be sure to replace with minimum metric class 8.8 specification.

**Kolpin Outdoors, Inc.**

**Telephone: (763)-478-5800**

**Toll Free: (877)-956-5746**

**Fax Number: (800)-245-7569**

**[www.kolpin.com](http://www.kolpin.com)**

**Email: [customerservice@kolpin.com](mailto:customerservice@kolpin.com)**



# POLY BLADE KIT

P/N 31-2060 / 31-2072 / 31-2084

ASSEMBLY / SPARE PARTS MANUAL

## Application

PLOW PUSH FRAME NO. 33-0000, 33-0070 or 35-0070

Before you begin, please read these instructions and check to be sure all parts and tools are accounted for. The following instructions contain details required to install and service the contents of this kit.

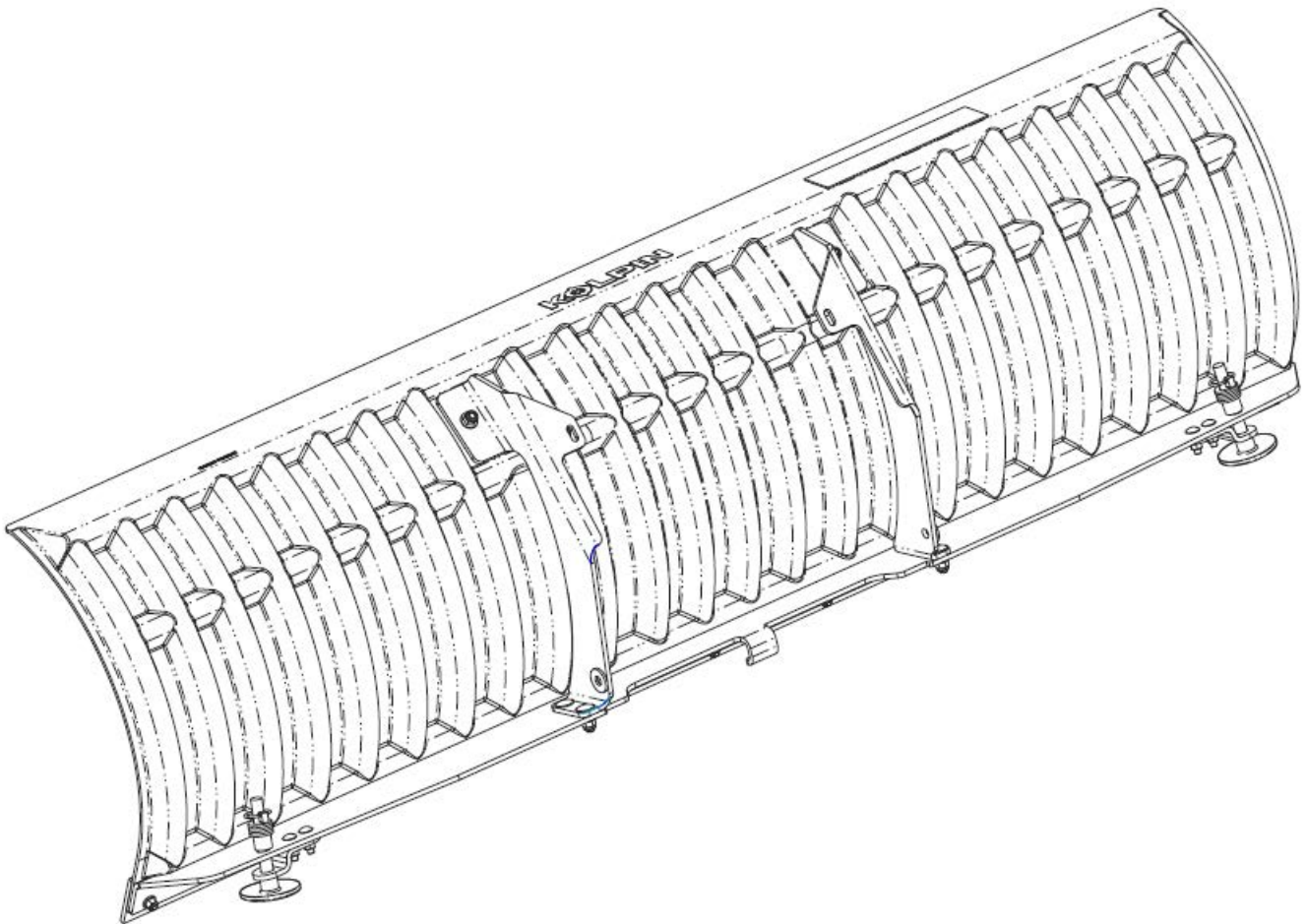

# OPERATING INSTRUCTIONS

Congratulations! You've just purchased one of the industry's top plow system component. The Poly Blade works great for all types of plowing. With proper care and maintenance, your plow blade will last for many years! The 60" (152 cm) / 72" (183 cm) / 84" (213 cm) Blade Assembly allows for quality snow moving capacity and snow roll-over characteristics. Additionally, this blade will handle light to medium-duty summer landscape work.

<b>NOTICE</b>
<b>Plow operation requires additional components for operation: <i>Kolpin Plow Push Frame, Winch Kit, ATV / UTV Plow Mount</i> *</b>
<i>*These components may be specific to your vehicle.</i>



Please read and understand all assembly instructions, notices and warnings before assembling and operating your plow system.

### Follow these guidelines to ensure satisfactory operation:

- Read this manual and your ATV/ UTV operators manual before use.
- Periodically check for wear and tightness of all fasteners. Replace or re-torque fasteners as necessary.
- Before first use, set plow in the furthest right or left angled position to check for clearance between the plow and front tires.
- Operate with extreme caution on slopes and rough terrain. Be familiar with the area before you plow.
- Be aware of immovable objects that could be hidden in the area you are plowing.
- To avoid damage when pushing snow into a pile, reverse direction before raising the plow blade.
- Do not ram the plow blade into piles of snow.
- For best results, set the suspension preload of your ATV/ UTV to the stiffest setting.
- To reduce steering effort and increase mobility, set the air pressure of your tires to the maximum pressure specification.
- The plow skids are adjustable. General skid setting is even with the plow wear bar bottom edge, higher settings reduce the chance of rocks and gravel from being collected.
- To increase traction during plow operation, operators can try: Securing weight to the ATV/ UTV for additional tire downforce, reducing tire air pressure, or installing tire chains.

# SAFETY INFORMATION

Our plow systems were designed with your safety in mind. Please read and understand all Cautions, Notices and Warnings in this manual before you begin. In order to protect you and your ATV, certain parts of the plow system and/or hardware are designed to fail when the equipment is over-stressed.

 <b>WARNING</b> 
<b>TO AVOID SERIOUS INJURY OR DEATH:</b>
1. <b>DO NOT EXCEED 5 MPH (8 KMH) WITH BLADE INSTALLED</b>
2. <b>OPERATE WITH EXTREME CAUTION ON SLOPES, STEEP GRADES, AND ROUGH TERRAIN</b>
3. <b>ALLOW NO RIDERS ON BLADE OR ATV WHILE MOVING OR STATIONARY</b>
4. <b>KEEP BYSTANDERS AWAY FROM THE BLADE OR ATV WHILE MOVING OR STATIONARY</b>
5. <b>WHEN PUSHING HEAVY MATERIAL, DIRECTION CONTROL MAY BECOME DIFFICULT</b>
6. <b>BEFORE ADJUSTING BLADE: STOP ATV ENGINE; SET AND LOCK BRAKES; RAISE AND LOCK BLADE</b>
7. <b>LOWER BLADE TO DOWN POSITION WHEN BLADE AND ATV ARE NOT IN USE</b>
8. <b>READ BLADE INSTRUCTION SHEETS AND ATV OWNER'S MANUAL</b>

# 31-2060 / 31-2072 / 31-2084 Kit Contents:

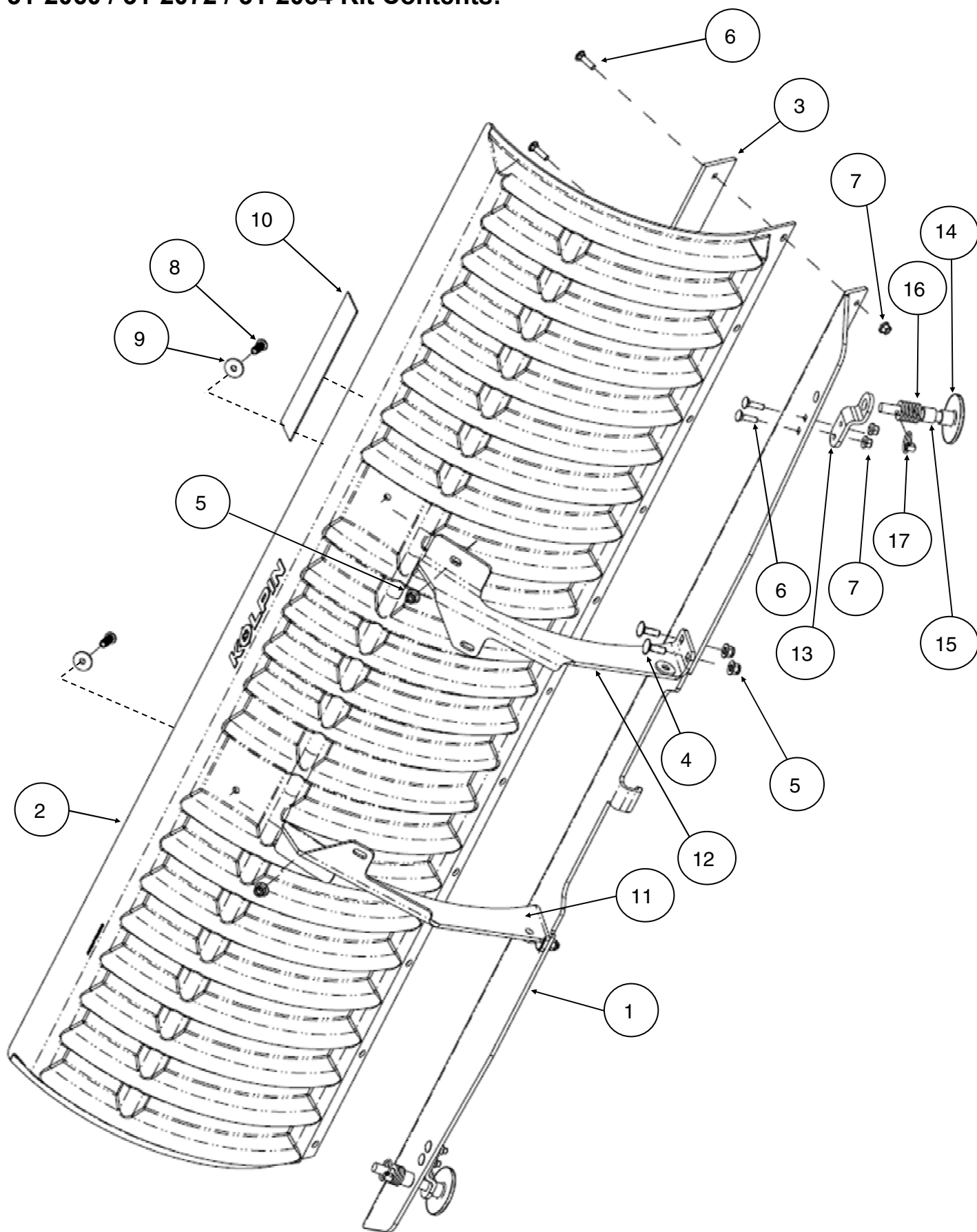

### 31-2060 / 31-2072 / 31-2084 Kit Contents (continued):

Item	Qty	Part Description	Part Number
1	1	60" Rear Angle Blade Support	-
1	1	72" Rear Angle Blade Support	-
1	1	84" Rear Angle Blade Support	-
2	1	60" Plastic Moldboard Blade	31-2060-CP01
2	1	72" Plastic Moldboard Blade	31-2072-CP01
2	1	84" Plastic Moldboard Blade	31-2084-CP01
3	1	60" Wear Bar, Double Sided	31-2160
3	1	72" Wear Bar, Double Sided	31-2172
3	1	84" Wear Bar, Double Sided	31-2184
4	4	Carriage Bolt, Zinc Plated, M10-1.50 X 30mm LG	-
5	6	Hex Flange Lock Nut, Zinc Plated, M10-1.50	-
6	13	(60" kit) Carriage Bolt, Zinc Plated, M8-1.25 X 30mm LG	-
6	15	(72" kit) Carriage Bolt, Zinc Plated, M8-1.25 X 30mm LG	-
6	17	(84" kit) Carriage Bolt, Zinc Plated, M8-1.25 X 30mm LG	-
7	13	(60" kit) Hex Flange Lock Nut, Zinc Plated, M8-1.25	-
7	15	(72" kit) Hex Flange Lock Nut, Zinc Plated, M8-1.25	-
7	17	(84" kit) Hex Flange Lock Nut, Zinc Plated, M8-1.25	-
8	2	Button Head Cap Screw, Zinc Plated, M10-1.5 X 30mm LG	-
9	2	Fender Washer, Zinc Plated, M10	-
10	1	Top Warning Decal	31-2072-CP03
11	1	Vertical Rib Blade Support, LH	-
12	1	Vertical Rib Blade Support, RH	-
13	2	Skid Bracket	-
14	2	Skid Shoe	PUR1467
15	4	Spacer	-
16	10	Flat Washer, Zinc Plated, M18	-
17	2	Lynch Quick Pin, Zinc Plated, 4.76mm Dia x 38mm LG	PUR1359
18	1	Instruction Guide (not shown)	-

## BEFORE YOU BEGIN:

- Your Kolpin accessory is exclusively designed for your vehicle.
- Please read and understand all instructions.
- Verify all parts and tools are accounted for.
- To ensure a satisfactory installation, follow all steps correctly and in the sequence described.
- Keep these instructions for future reference or for informational requests.
- To facilitate installation, make sure that your vehicle is clean and free of debris.
- All directions referring to right and left are when the rider is sitting on the machine.

## TOOLS REQUIRED:

- Basic Metric Wrench and Socket Set
- Torque Wrench

## APPROXIMATE ASSEMBLY TIME: 15 minutes

Note: If any hardware is missing, do not return to the store. Call us to help, Toll Free 1-877-956-5746.

## SPARE KIT INFORMATION:

SPARE KITS		Wear bar kit P/N 31-2160 / 31-2172 / 31- 2184	Skid shoe kit P/N 31-2155	Hardware kit P/N 31-2073	Wear bar bolt kit P/N 12-0010
Item	Description				
3	Wear Bar, Double Sided	1x / 1x / 1x			
4	Carriage Bolt, Zinc Plated, M10-1.50 X 30mm LG			4x	
5	Hex Flange Lock Nut, Zinc Plated, M10-1.50			6x	
6	Carriage Bolt, Zinc Plated, M8-1.25 X 30mm LG	9x / 11x / 13x		15x	11x
7	Hex Flange Lock Nut, Zinc Plated, M8-1.25	9x / 11x / 13x		15x	11x
8	Button Head Cap Screw, Zinc Plated, M10-1.5 X 30mm LG			2x	
9	Fender Washer, Zinc Plated, M10			2x	
14	Skid Shoe		2x		
15	Spacer		4x	4x	
16	Flat Washer, M18		10x	10x	
17	Lynch Quick Pin, Zinc Plated, 4.76mm Dia x 38mm LG		2x	2x	

## Spare Kit Notes:

- Spare kits may contain extra hardware that is used for other mount kits. Extra hardware can be discarded.

## USE AND CARE INFORMATION:

Note: The wear bar cutting edge is double-sided, so when bottom side wears thin, flip the bar over and use the top side for extended cutting edge life.



## ASSEMBLY INSTRUCTIONS:

1. Attach vertical rib blade supports (items #11 and #12) to the rear angle blade support (item #1) as shown. Use M10 carriage screws (item #4) and fasten with M10 locknut (item #5). (See illustration 1-1). **Note, do not fully tighten at this time.**
2. Attach the assembled support to the moldboard blade (item #2) at the upper locations using fender washers (item #9) and M10 button cap screws (item #8) as shown. Fasten using M10 locknuts (item #5). **Note, do not fully tighten at this time.**

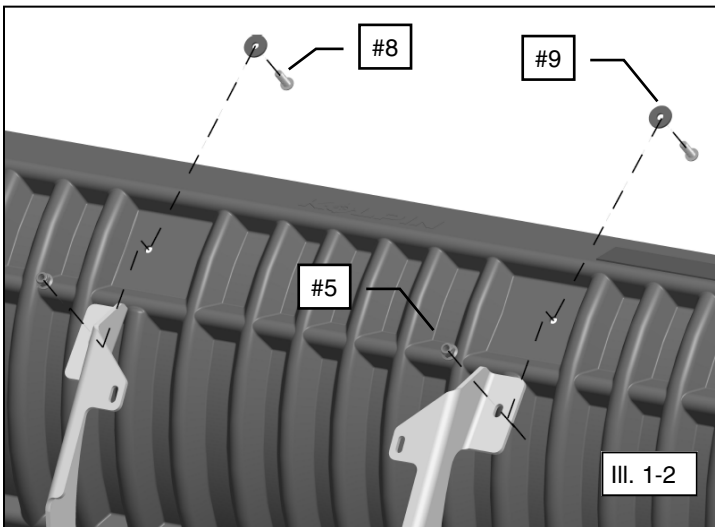
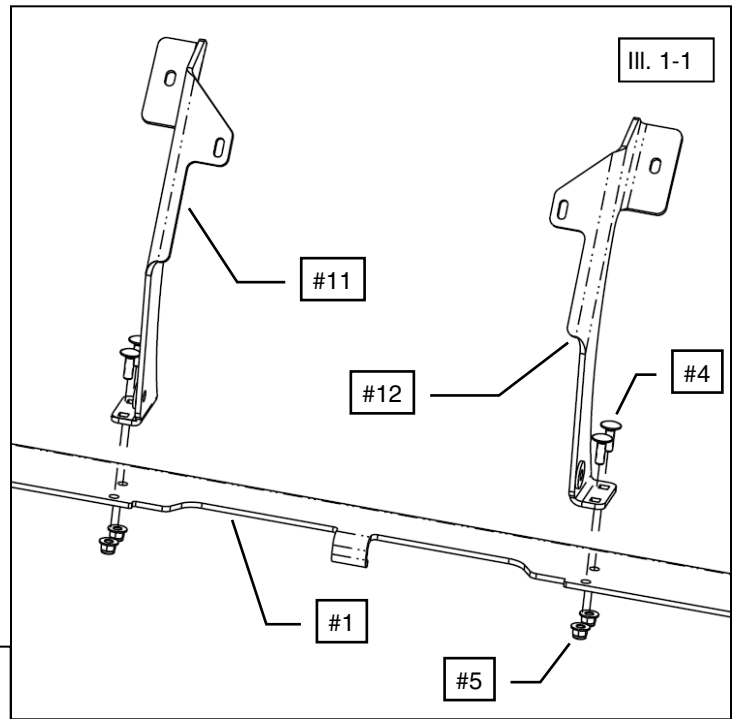

3. Place the blade assembly on its back and attach the wear bar (item #3) to the blade and support assembly using the M8 carriage bolts (item #10) as shown. Fasten using M8 locknuts (item #7). (See illustration 1-3). **Note, start with the middle wear bar hole first. The middle hole in the plastic moldboard is smaller to help index/center the blade.**
4. Torque M8 fasteners to specification.

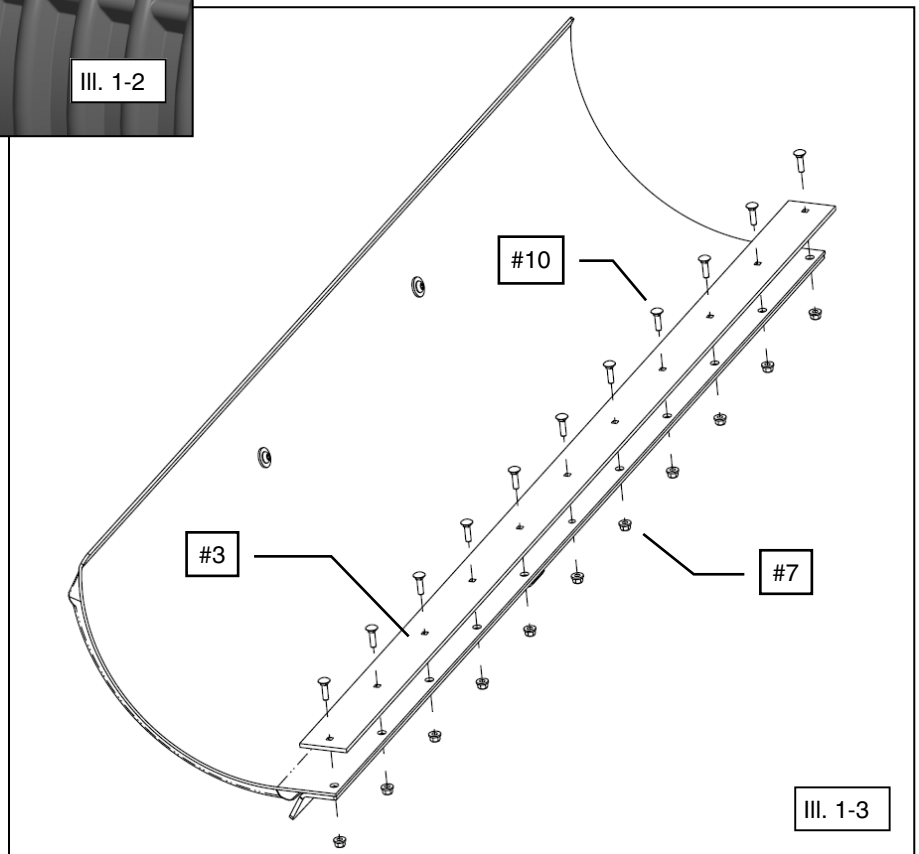

<b>8MM FASTENER TORQUE:</b> 17 ft. lbs. (23 Nm)

## ASSEMBLY INSTRUCTIONS (continued):

5. Torque the lower vertical support rib fasteners (items #4 and #5) to specification below.

 = T
<b>LOWER SUPPORT RIB FASTENER TORQUE:</b> 30 ft. lbs. (41 Nm)

6. Torque the lower vertical support rib fasteners (items #8 and #5) to specification below.

 = T
<b>UPPER SUPPORT RIB FASTENER TORQUE:</b> 17 ft. lbs. (23 Nm)

7. Attached skid brackets (item #13) to each end of the rear angle support (item #1) using M8 carriage screws (item #6) as shown. Fasten using M8 locknuts (item #7). (See illustration 1-4).

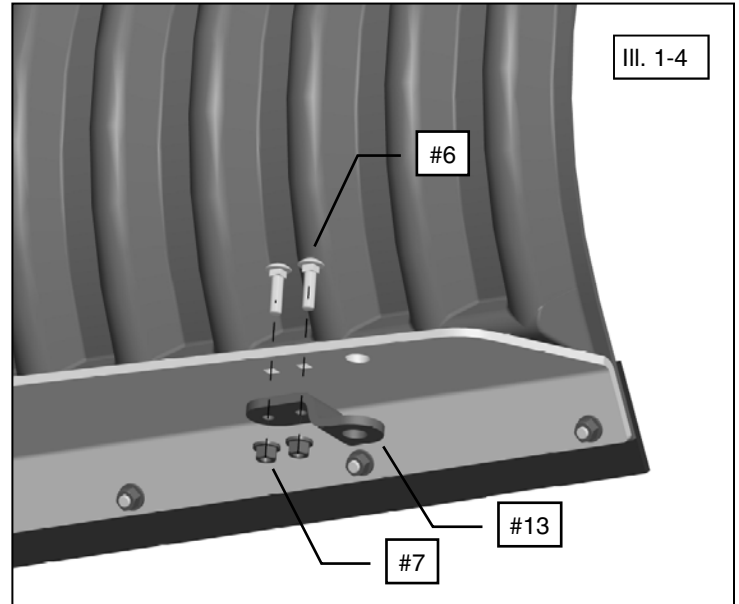

8. Torque to M8 specification.

 = T
<b>8MM FASTENER TORQUE:</b> 17 ft. lbs. (23 Nm)

9. Assemble and install skid components (items #14, #15 and #16) as shown. Fasten using quick pins (items #17). (See illustration 1-5). **Note, initial setting of skid height depends on the terrain. Set the skids even with the wear bar cutting edge for level surfaces such as concrete or asphalt. For irregular surfaces, lower the skids to raise the wear bar cutting edge.**

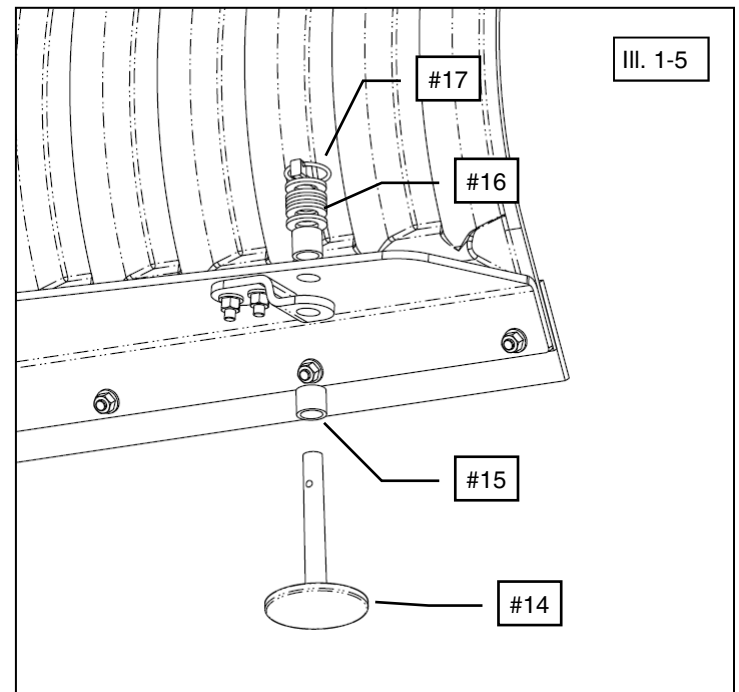



## Two Year Limited Warranty

For the period of two (2) years from the purchase date, Kolpin will replace for the original purchaser, free of charge, any part or parts found upon examination by Kolpin to be defective in material, workmanship, or both.

All transportation costs incurred submitting product to Kolpin for warranty consideration must be borne by the purchaser. If Kolpin determines that the product must be returned to the factory for credit, please call 1-877-956-5746 for a Return Merchandise Authorization (RMA) number and shipping instructions.

This warranty does not apply to parts that have been damaged by accident, alteration, abuse, improper maintenance, normal wear, or other causes beyond the manufacturer's control. In order to protect you and your ATV, certain parts of the plow system and/or hardware are designed to fail when the equipment is over-stressed. Parts that are lost due to loosening and improper maintenance are not covered under warranty. This warranty does not cover removal or reinstallation labor fees of the plow system and related components.

Peripheral products such as engines, electric motors, and actuators may carry an original manufacturer's warranty. Most hardware is general in nature and is easily obtained locally. Be sure to replace with minimum metric class 8.8 specification.

**Kolpin Outdoors, Inc.**

**Telephone: (763)-478-5800**

**Toll Free: (877)-956-5746**

**Fax Number: (800)-245-7569**

**[www.kolpin.com](http://www.kolpin.com)**

**Email: [customerservice@kolpin.com](mailto:customerservice@kolpin.com)**



# UTV CONQUEROR FRONT-CONNECT PUSH FRAME KIT

P/N 35-0070

## OWNER'S MANUAL

Application

CONQUEROR FRONT-CONNECT PLOW MOUNT NO. 35-XXXX

**ATTENTION DEALER: CUSTOMER MUST RECEIVE A COPY OF THIS MANUAL  
AT THE TIME OF SALE.**

Before you begin, please read these instructions and check to be sure all parts and tools are accounted for. These instructions will help you to become familiar with operation of the plow push frame. Instructions contain details required to install, service the contents of this kit, for adjustment and maintenance.

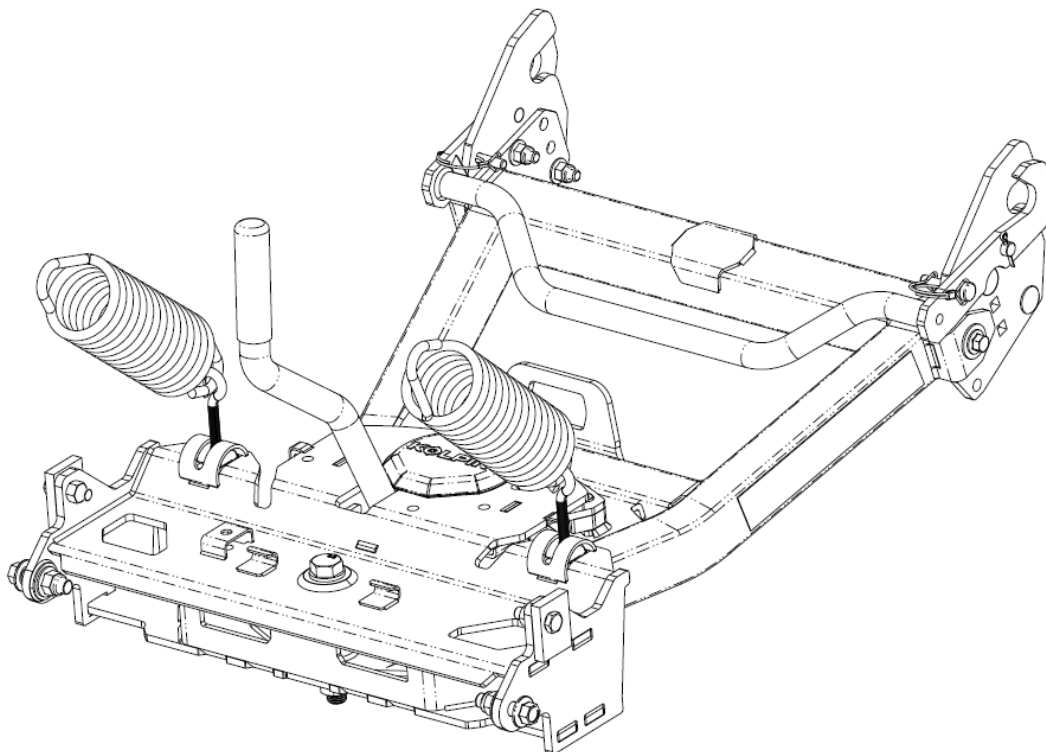

## INTRO

Thank you for purchasing Kolpin engineered products. With proper installation, usage, care, and maintenance, your Kolpin product will last for years to come.

## BEFORE YOU BEGIN

- Your Kolpin accessory is exclusively designed for your vehicle.
- Read and understand the entire installation manual, including all installation instructions, operating instructions, safety warnings and guidelines before installing or operating your accessory. Failure to comply may result in damage to the product and / or vehicle, and can lead to hazards up to and including death.
- Verify all parts and tools are accounted for. If parts are missing, do not return to the store. Call us for help, **Toll Free 1-877-956- 5746**
- Follow all steps correctly and in the sequence described.
- Keep these instructions for future reference or for informational requests.
- To facilitate installation, make sure that your vehicle is clean and free of debris.
- All directions referring to right and left are from the rider perspective when sitting on the machine.

## ASSEMBLY TIME

Approximately 24 minutes

## SAFETY INFORMATION

Please read and understand all Cautions, Notices, and Warnings in this manual before you begin. In order to protect you and your ATV / UTV, certain parts of the plow system and / or hardware are designed to fail when the equipment is overstressed.

### Follow these guidelines to ensure satisfactory operation:

- Read this manual and your ATV / UTV operators manual before use.
- Periodically check for wear and tightness of all fasteners. Replace or re-torque fasteners as necessary.
- Before first use, set plow in the furthest right or left angled position to check for interference with the vehicle.
- Operate with extreme caution on slopes and rough terrain. Be familiar with the area before you plow.
- Be aware of immovable objects that could be hidden in the area you are plowing.
- To avoid damage when pushing snow into a pile, reverse direction before raising the plow blade.
- Do not ram the plow blade into piles of snow.
- For best results, set the suspension preload of your ATV / UTV to the stiffest setting.
- To reduce steering effort and increase mobility, set the air pressure of your tires to the maximum pressure specification.
- The plow skids are adjustable. General skid setting is even with the plow wear bar bottom edge, higher settings reduce the chance of rocks and gravel from being collected.
- To increase traction during plow operation, operators can try: Securing weight to the ATV / UTV for additional tire downforce, reducing tire air pressure, or installing tire chains.



## WARNING



### TO AVOID SERIOUS INJURY OR DEATH:

1. DO NOT EXCEED 5 MPH (8 KMH) WITH BLADE INSTALLED
2. OPERATE WITH EXTREME CAUTION ON SLOPES, STEEP GRADES, AND ROUGH TERRAIN
3. ALLOW NO RIDERS ON BLADE OR ATV WHILE MOVING OR STATIONARY
4. KEEP BYSTANDERS AWAY FROM THE BLADE OR ATV WHILE MOVING OR STATIONARY
5. WHEN PUSHING HEAVY MATERIAL, DIRECTION CONTROL MAY BECOME DIFFICULT
6. BEFORE ADJUSTING BLADE: STOP ATV ENGINE; SET AND LOCK BRAKES; RAISE AND LOCK BLADE
7. LOWER BLADE TO DOWN POSITION WHEN BLADE AND ATV ARE NOT IN USE
8. READ BLADE INSTRUCTION SHEETS AND ATV OWNER'S MANUAL

## REQUIRED SOLD SEPARATELY

Only parts for installation of the Plow Push Frame Kit are included. For complete snow plow system installation, additional items are required such as a plow blade, vehicle plow mount, winch, and winch mount. See [www.Kolpin.com](http://www.Kolpin.com) for products to complete your plow system.

## TOOLS REQUIRED

- Safety Glasses
- Socket Set, Metric
- Torque Wrench
- Wrench Set, Metric
- Pliers, Needle Nose
- Spring Puller or shoestring sized rope

## IMPORTANT

The use of a Kolpin winch with the combination of Kolpin auto-stop and synthetic winch rope are recommended for use with this plow system to prevent premature failure of the winch cable. The winch should be installed on the unit prior to installing this kit.

**KIT CONTENTS**

Item	Qty	Part Description	Part Number
1	1	Push Frame Welded	-
2	1	Blade Pivot Frame	-
3	1	Pivot Lock Handle	35-0077
4	1	Pivot Lock Gear Plate	35-0078
5	1	Connection Latch Handle	35-0070-CP06
6	1	LH Connection Latch Side Bracket	35-0070-CP27
7	1	RH Connection Latch Side Bracket	35-0070-CP26
8	1	Plastic Pivot Cover Cap	35-0070-CP24
9	1	Lift Bracket	35-0075
10	2	Large Tension Spring, Blade Trip	35-0070-CP12
11	1	Small Tension Spring, Pivot Lock Handle	-
12	1	Hex Screw, Zinc Plated, M6-1.0 x 18mm LG	-
13	1	Lock Washer, Zinc Plated, M6	-
14	2	Lock Pin	35-0079
15	2	Cotter Pin	-
16	4	Carriage Screw, Zinc Plated, M10-1.5 x 35mm LG	-
17	4	Hex Flange Locknut, Zinc Plated, M10-1.5	-
18	2	Hex Flange Screw, Zinc Plated, M10-1.5 x 35mm LG	-
19	2	Lock Washer, Zinc Plated, M10	-
20	2	Flat Washer, Zinc Plated, M10	-
21	1	Kolpin Logo Decal	-
22	1	Conqueror Decal	-
23	3	Hex Flange Screw, Zinc Plated, M8-1.25 x 65mm LG	35-0075
24	10	Hex Flange Locknut, Zinc Plated, M8-1.25	-
25	2	Hex Flange Screw, Zinc Plated, M12-1.75 x 45mm LG	-
26	2	Hex Flange Locknut, Zinc Plated, M12-1.75	-
27	2	Eye Bolt, Zinc Plated, M8-1.25 x 115mm LG	PUR1216
28	2	Pivot Sleeve, Zinc Plated	34-0002
29	2	Blade Stopper Plate, Zinc Plated	-
30	2	Hex Screw, Zinc Plated, M10-1.5 x 35mm LG	-
31	2	Hex Locknut, Zinc Plated, M10-1.5	-
32	5	Socket Head Cap Screw, Zinc Plated, M8-1.25 x 40mm LG	-
33	1	Hex Flange Screw, M16-2.0 x 120mm LG	-
34	1	Flat Washer, Zinc Plated, M16	-
35	1	Hex Flange Locknut, Zinc Plated, M16-2.0	-
36	1	Instruction Manual (not shown)	-

# Kit Contents (continued):

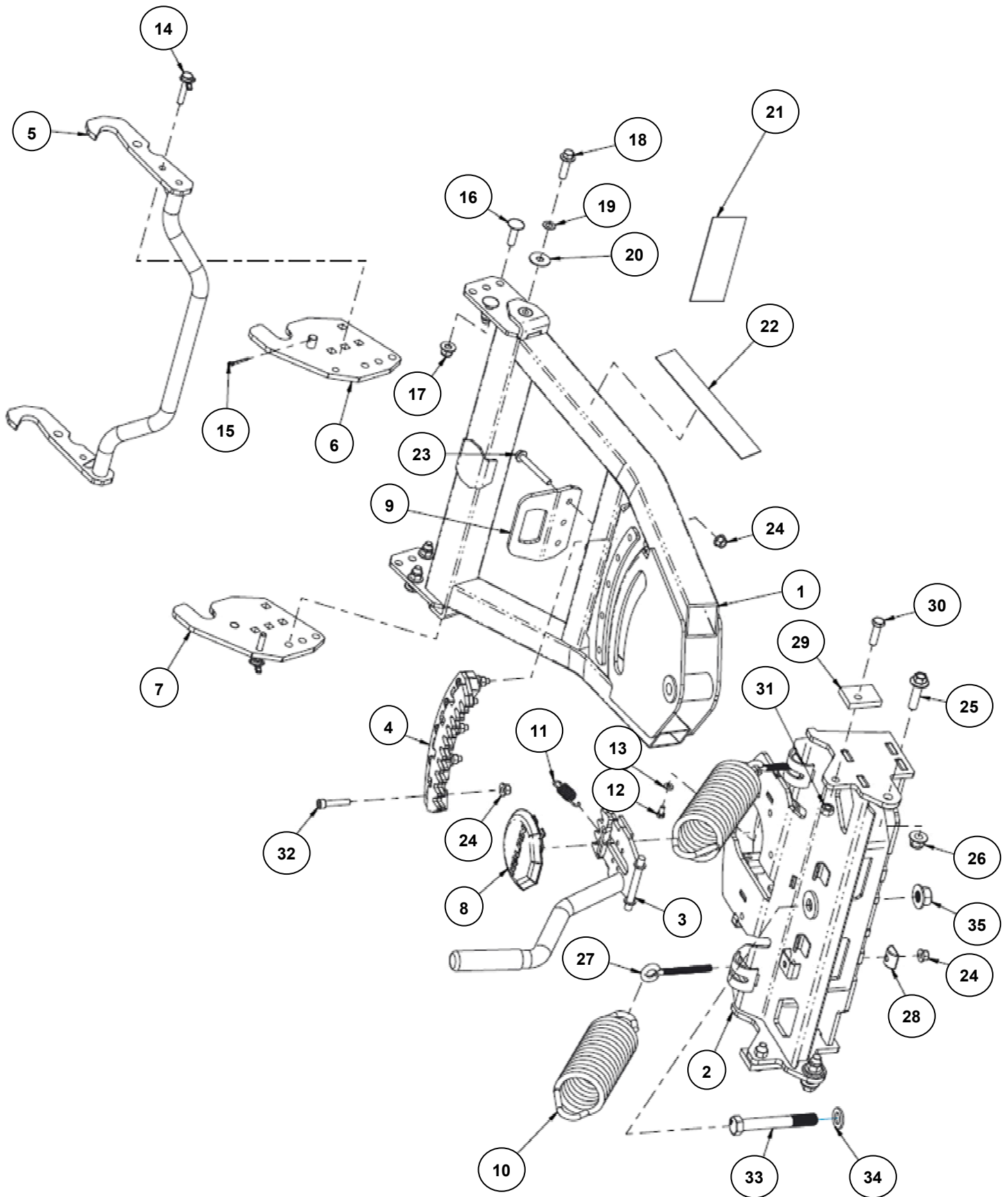





# INSTALLATION INSTRUCTIONS

## MANUAL PIVOT ANGLE ASSEMBLY

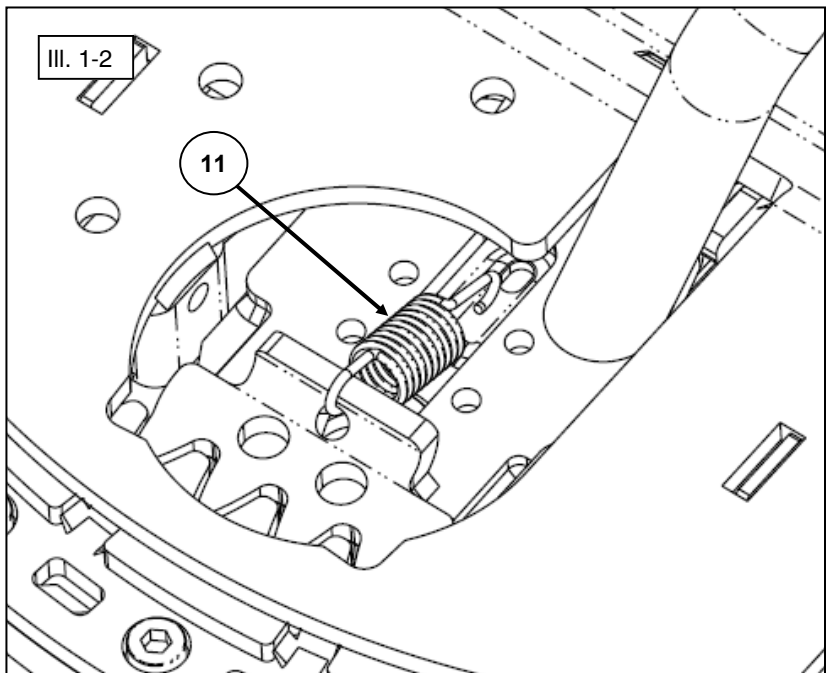
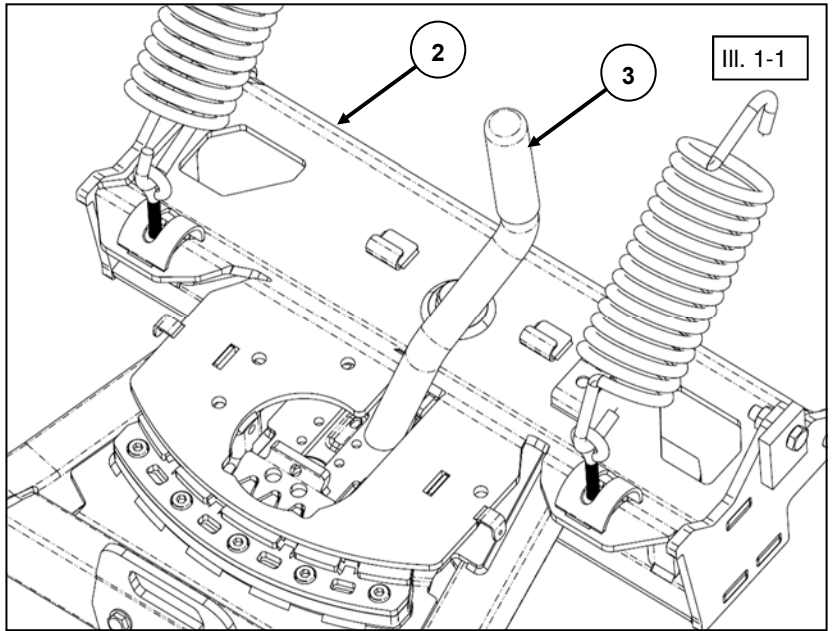
1. Position the pivot lock handle (item #3) into the blade pivot frame (item #2). Lock the handle assembly into place as shown. (See illustration 1-1).
2. Attach the tension spring (item #11) into the holes in the lock handle assembly and pivot frame assembly as shown. Using a spring puller (or shoe string) to pull on the higher side allows for easy installation of spring. (See illustration 1-2). **Note, the shorter spring end hook fits into the frame first.**
3. Install M6 hex screw (item #12) and M6 lock washer (item #13) in the pivot frame side plate hole as shown. Tighten to specification. (See illustration 1-3).
4. Secure the plastic cover cap (item #8) into place as shown. (See illustration 1-4).



 = T  
**6MM FASTENER TORQUE:**  
7 ft-lbs. (9 N-m)

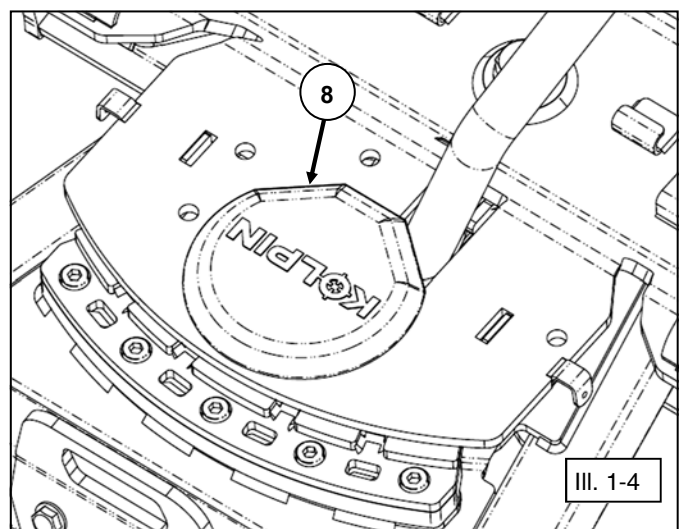
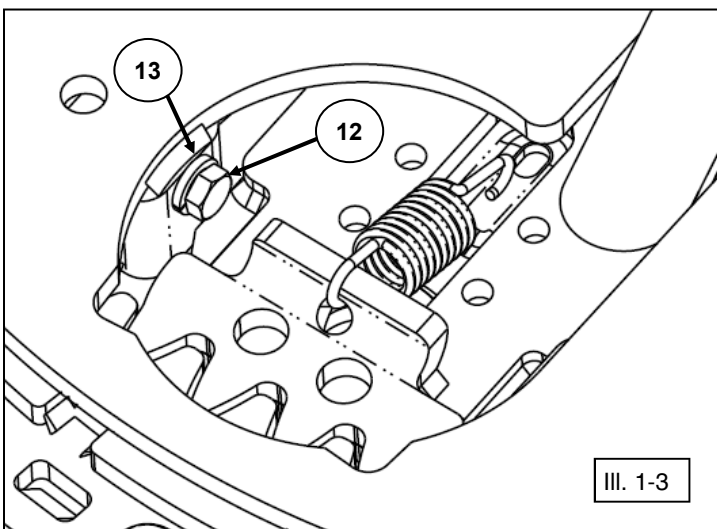

## INSTALLATION INSTRUCTIONS

### CONNECTION LATCH ASSEMBLY

- Position the connection latch handle (item #5) onto the LH connection latch side bracket (item #6). Insert the cotter pin (item #15) thru the welded pin of side bracket as shown. Bend cotter pin into place. Insert the lock pin (item #14) thru the latch and side bracket. Repeat the same steps for RH side bracket (item #7). (See illustration 1-5).
- Position the connection latch assembly onto the push frame (item #1) rear tabs as shown. Fasten the front of the side brackets using M10 hex flange screw (item #18) with M10 lock washer (item #19) and M10 flat washer (item #20). Fasten the rear two square holes of the side brackets using M10 carriage screws (item #16) with M10 locknuts (item #17). (See illustration 1-6). **Note, the connection latch assembly can be adjusted for higher ground clearance vehicles to keep plow blade level. See operation section of instruction guide.**
- Tighten M10 hardware to specification.

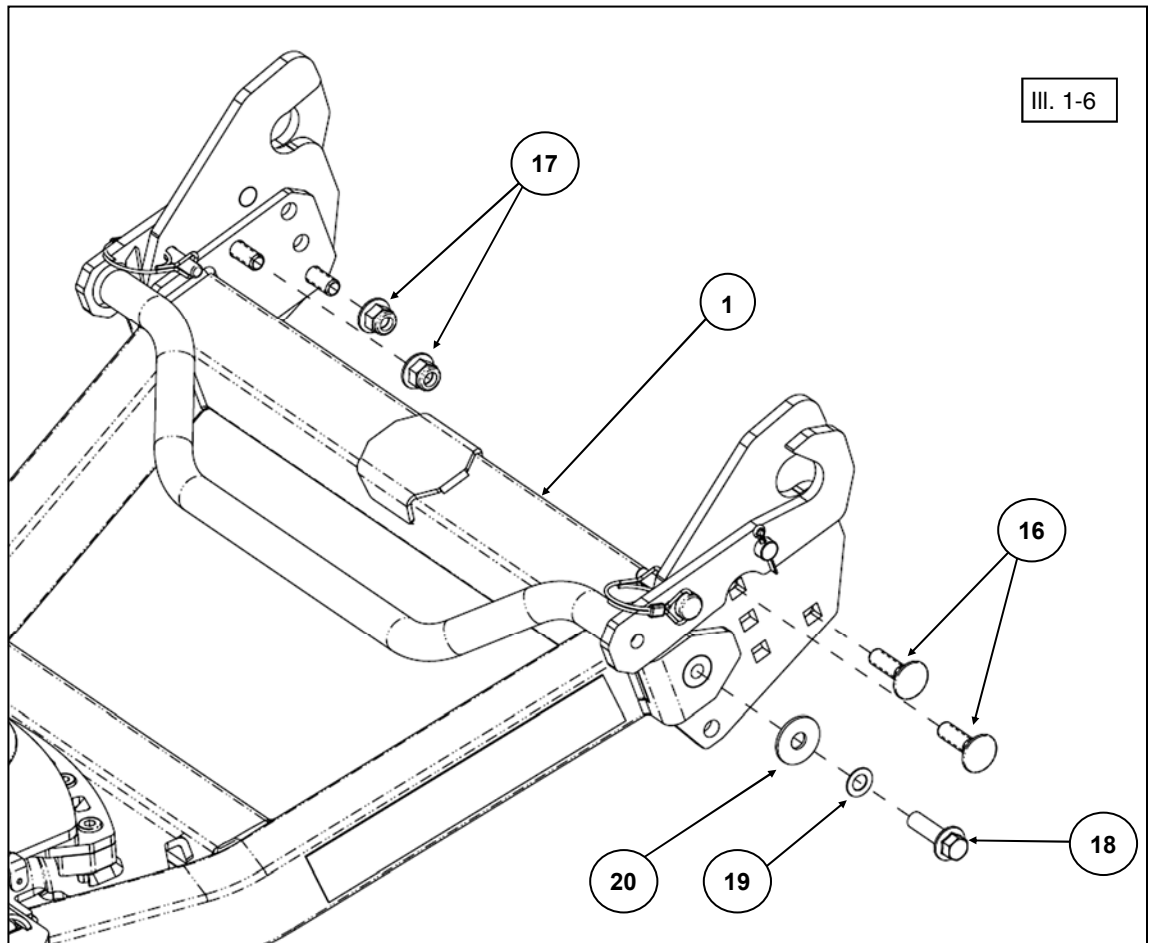
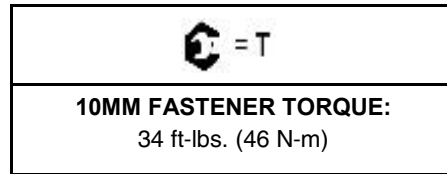
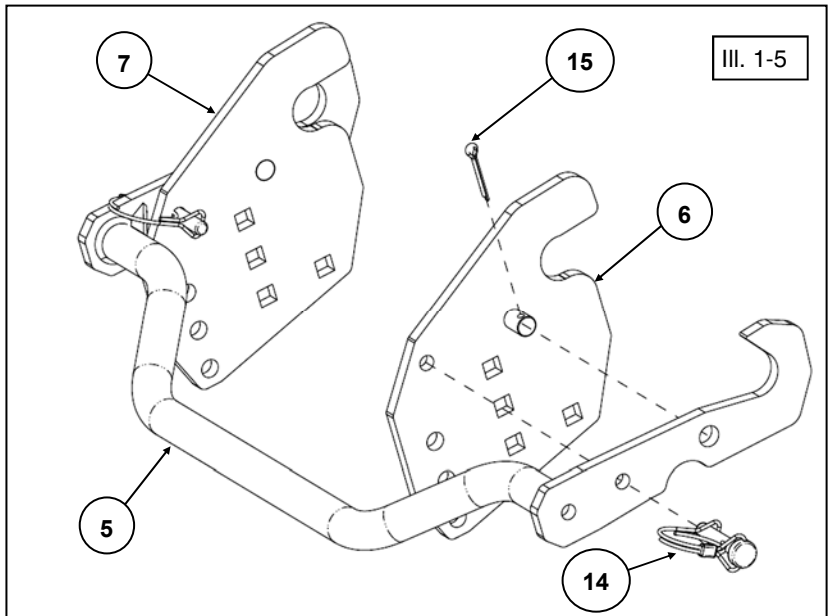

# INSTALLATION INSTRUCTIONS

## LIFT BRACKET ASSEMBLY

8. Position the lift bracket (item #9) onto the push frame (item #1) as shown. Fasten using M8 screws (item #23) with M8 locknuts (item #24). (See illustration 1-7).
9. The lift bracket (item #9) can be installed with loop facing forward or rearward as shown. (See illustration 1-8). **Note, facing the lift bracket loop forward can be helpful for Polaris Ranger 1000 applications and provide some winch rope winch clearance with OEM upper catch bar of front bumper. Otherwise, it can provide more winch rope clearance to remove the Polaris Ranger 1000 OEM upper catch bar.**
10. Tighten M8 screws to specification.

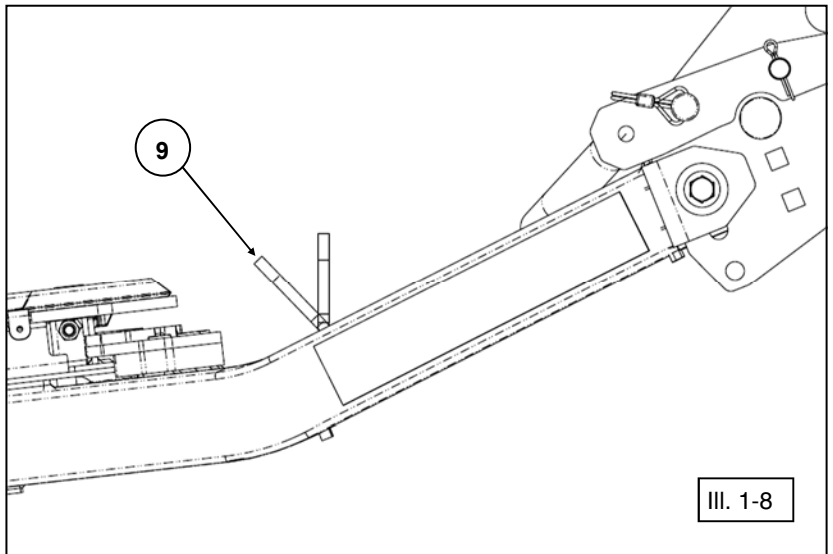
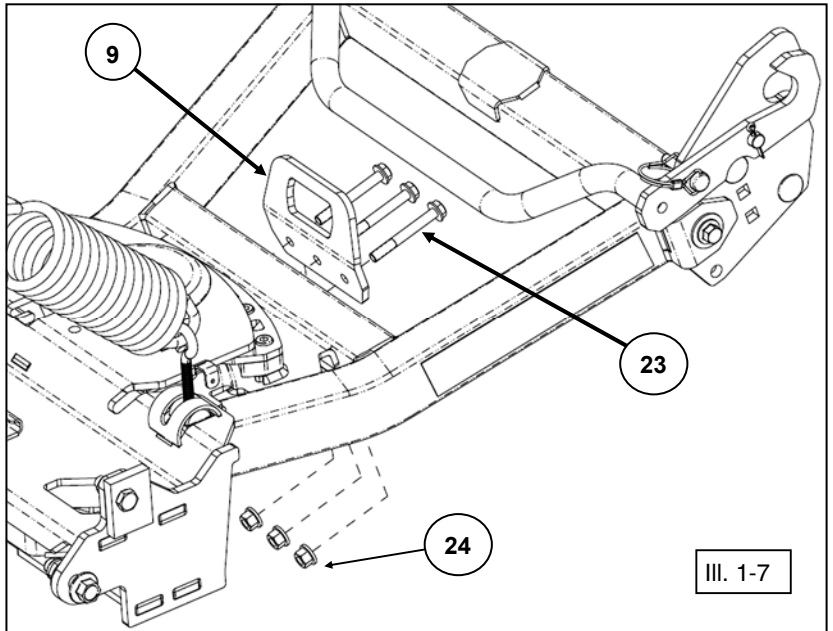

 = T
<b>8MM FASTENER TORQUE:</b> 17 ft-lbs. (23 N-m)

## INSTALLATION INSTRUCTIONS

### PLOW BLADE ASSEMBLY

11. Align the mounting holes in the frame pivot with the mounting holes in the blade as shown. Fasten using M12 screws (item #25) with M12 locknuts (item #26) by inserting the hardware thru blade holes and frame holes. Tighten locknut, then back out 1/8 turn to allow blade to hinge freely on frame. (See illustration 1-9).

**Note, screw should be tight enough to not move, but the blade must rotate freely.**

12. Assemble the large tension springs (item #10) and eyebolts (item #27) between the blade assembly and the spring pivot tab brackets. Fasten eyebolts to frame tab with half moon pivot sleeve (item #28) and M8 lock nuts (item #24) onto the eyebolts until 2-3 threads show thru the locking feature. (See illustration 1-10).

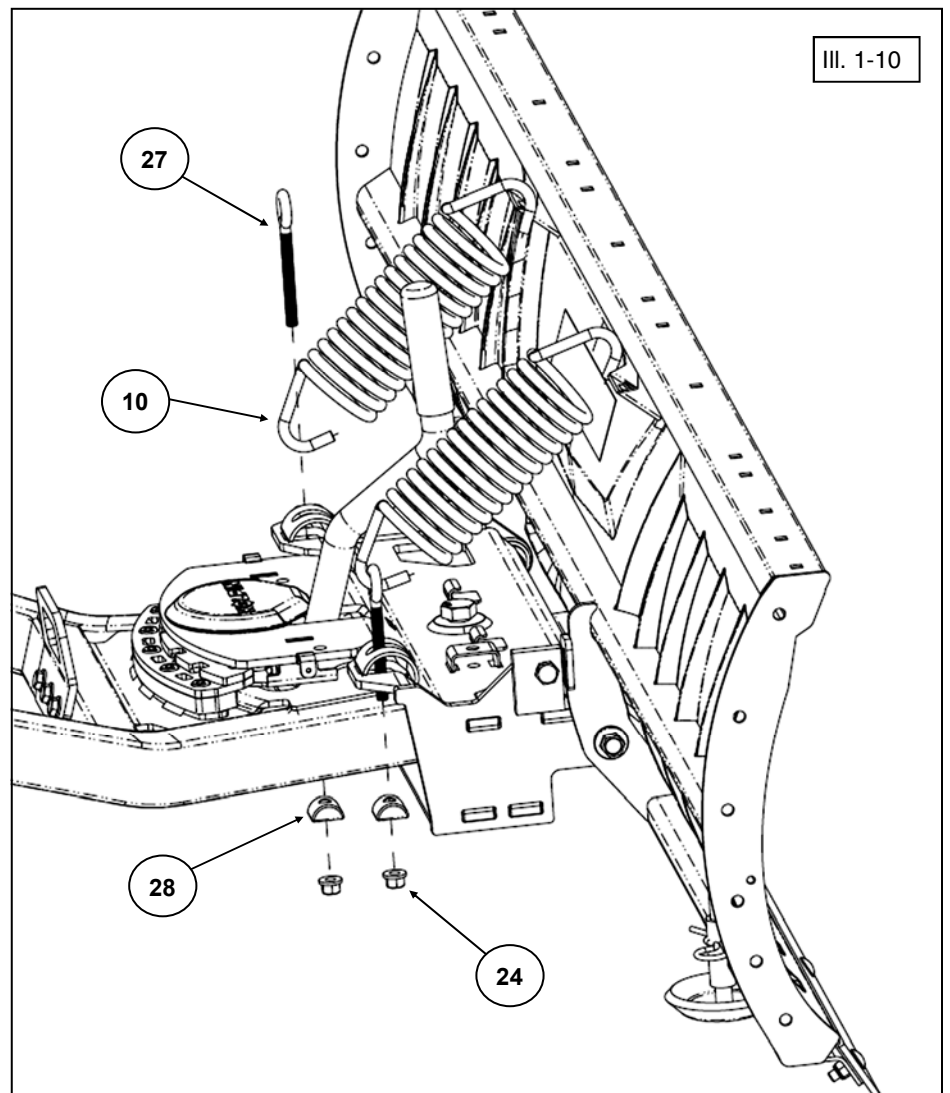
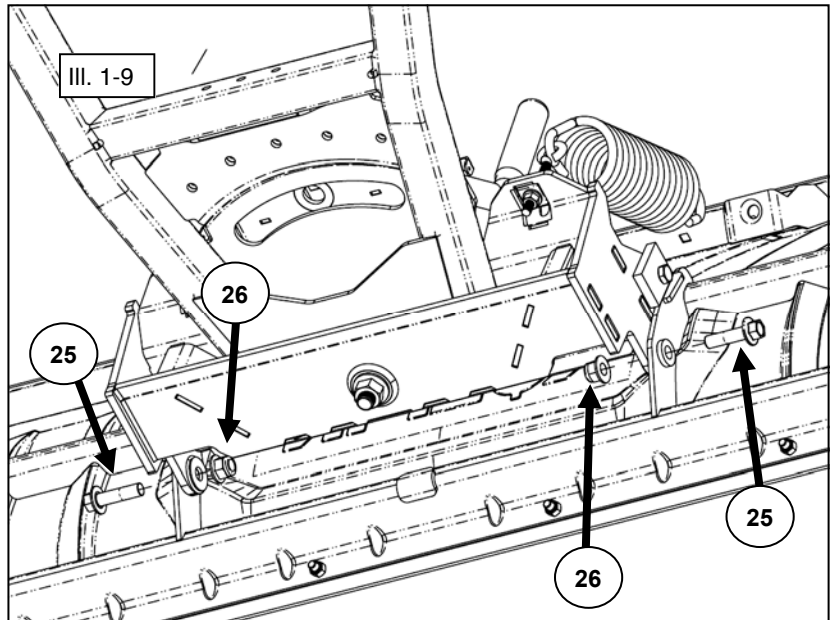





## INSTALLATION INSTRUCTIONS

### PLOW BLADE ASSEMBLY

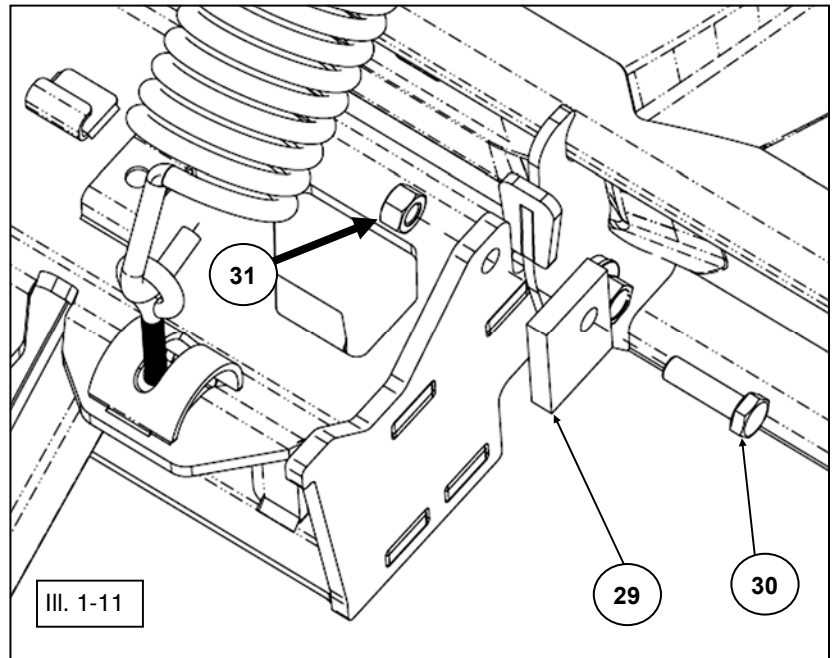
13. Install the blade stopper plates (item #29) onto pivot frame. Fasten with M10 hex screw (item #30) and M10 hex locknut (item #31) as shown. (See illustration 1-11). **Note, do not tighten fasteners at this time.**
14. Once plow system is mounted to the UTV, adjust the blade stops and blade trip spring tension as desired to achieve best performance. (See illustration 1-12).
15. Tighten the blade stopper plate fasteners to specification.



### BLADE STOPPER ADJUSTMENT

 = T
<b>10MM FASTENER TORQUE:</b> 34 ft-lbs. (46 N-m)

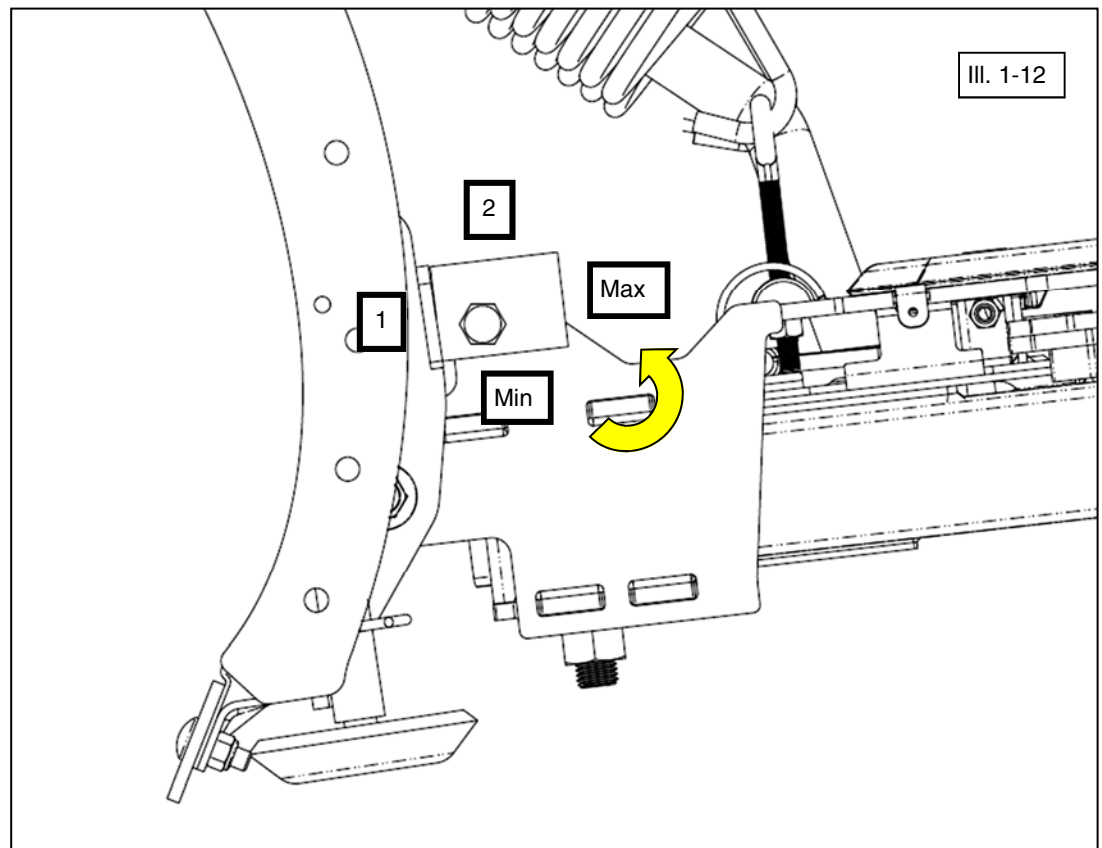

# INSTALLATION INSTRUCTIONS

## PLOW INSTALLATION

16. **Note, frame installation may require mount plate specific to your vehicle. Certain vehicles come equipped from the factory with the plow mount already attached to the vehicle.**
17. Lay the plow assembly on the ground in front of the vehicle. Make sure the lock pins (item #14) are removed to allow the connection latch (item #5) to swing freely. (See illustration 1-13).
18. Slide the assembly towards the vehicle so that the plow frame attachment pockets slide onto the vehicle plow mounting bar.
19. Once plow frame is fully seated onto the mounting bar, make sure the connection latch is rotated into position to allow the lock pins to be inserted. Insert the locking pins (item #14) being sure to latch the wire retaining clip to secure the pins in place. (See illustration 1-14).
20. Attach the winch's rope hook to the lift bracket loop (item #9) as shown. (See illustration 1-15).

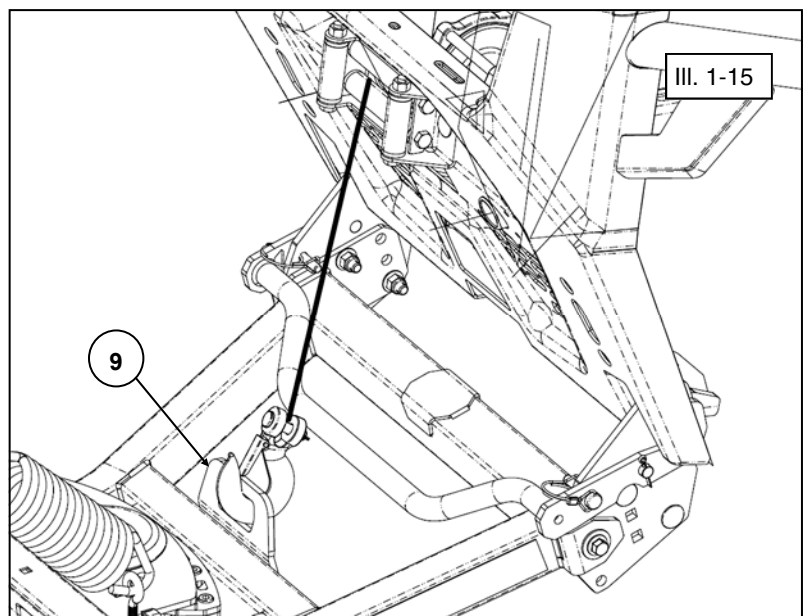
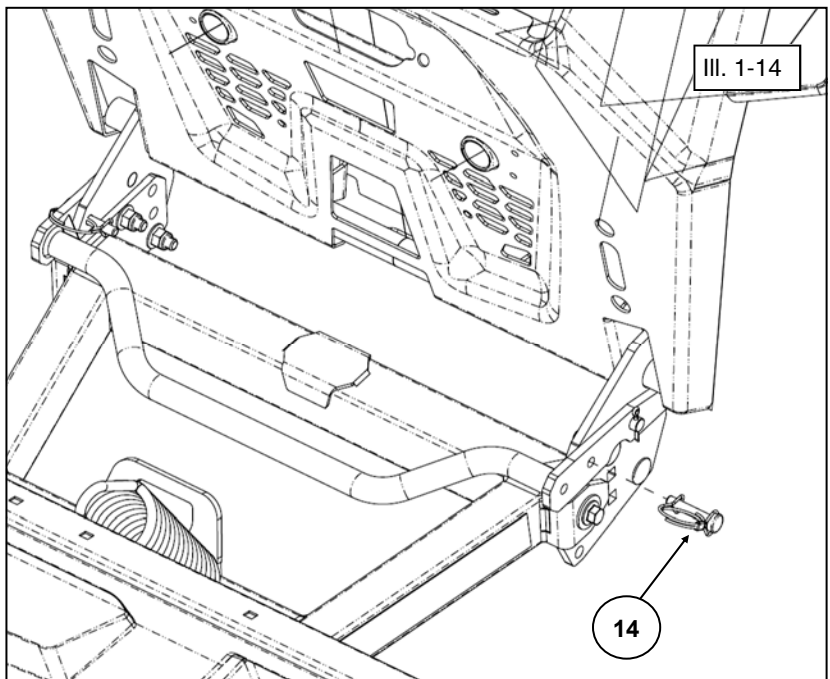
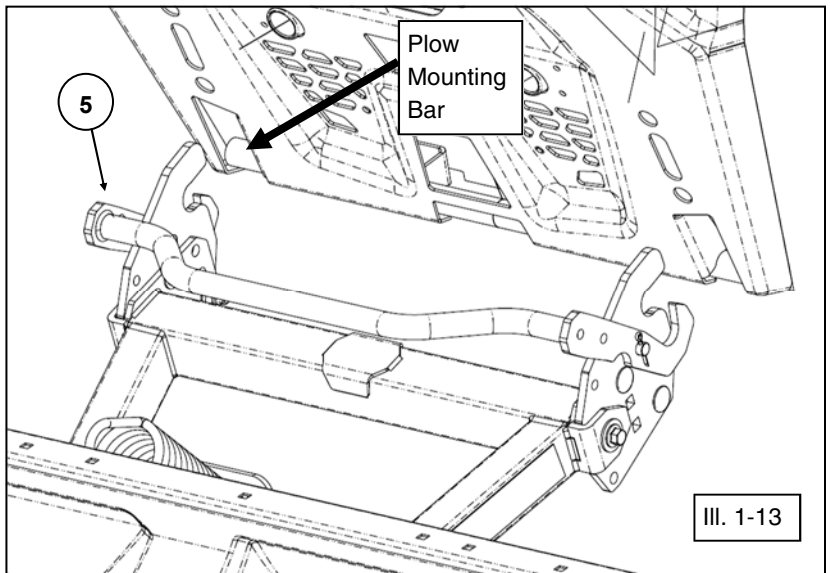

## INSTALLATION INSTRUCTIONS

### PLOW INSTALLATION

21. *Note, certain plow mounts have built-in receiver hitch. Clearance for opening the connection latch handle can be gained by using curved angle portion of tubing. (See illustrations 1-16 and 1-17).*

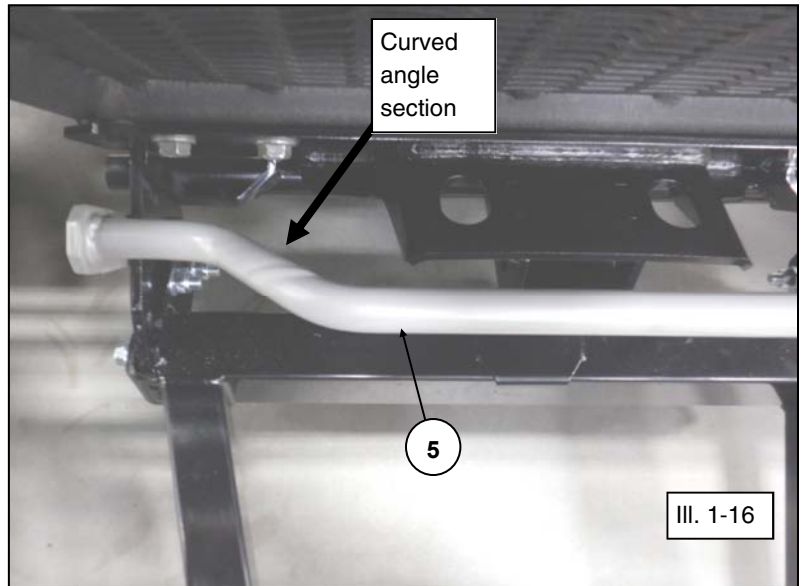

# SERVICE KITS

Item	Description	Hardware kit P/N 35-0076	Pivot Lock Handle kit P/N 35-0077	Lift Point Bracket kit P/N 35-0075	Pivot Gear Plate kit P/N 35-0078	Lock Pin kit P/N 35-0079	Eyebolt kit P/N 34-0002
3	Pivot Lock Handle		1x				
4	Pivot Lock Gear Plate				1x		
9	Lift Bracket	2x		1x			
11	Small Tension Spring, Pivot Lock Handle	4x	1x				
12	Hex Screw, Zinc Plated, M6-1.0 x 18mm LG	1x	1x				
13	Lock Washer, Zinc Plated, M6	1x	1x				
14	Lock Pin	2x				2x	
15	Cotter Pin	2x					
16	Carriage Screw, Zinc Plated, M10-1.5 x 35mm LG	4x					
17	Hex Flange Locknut, Zinc Plated, M10-1.5	4x					
18	Hex Flange Screw, Zinc Plated, M10-1.5 x 35mm LG	2x					
19	Lock Washer, Zinc Plated, M10	2x					
20	Flat Washer, Zinc Plated, M10	2x					
23	Hex Flange Screw, Zinc Plated, M8-1.25 x 65mm LG	3x		3x			
24	Hex Flange Locknut, Zinc Plated, M8-1.25	10x		3x	5x		2x
25	Hex Flange Screw, Zinc Plated, M12-1.75 x 45mm LG	2x					
26	Hex Flange Locknut, Zinc Plated, M12-1.75	2x					
27	Eye Bolt, Zinc Plated, M8-1.25 x 115mm LG	2x					2x
28	Pivot Sleeve, Zinc Plated	2x					2x
29	Blade Stopper Plate, Zinc Plated	2x					
30	Hex Screw, Zinc Plated, M10-1.5 x 35mm LG	2x					
31	Hex Locknut, Zinc Plated, M10-1.5	2x					
32	Socket Head Cap Screw, Zinc Plt, M8-1.25 x 40mm LG	5x			5x		
33	Hex Flange Screw, M16-2.0 x 120mm LG	1x					
34	Flat Washer, Zinc Plated, M16	1x					
35	Hex Flange Locknut, Zinc Plated, M16-2.0	1x					



# SERVICE KITS

See the table on page 13 for a full description.

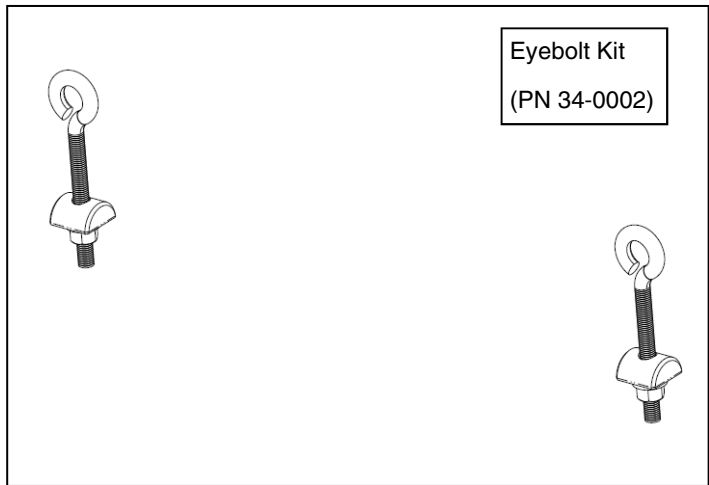
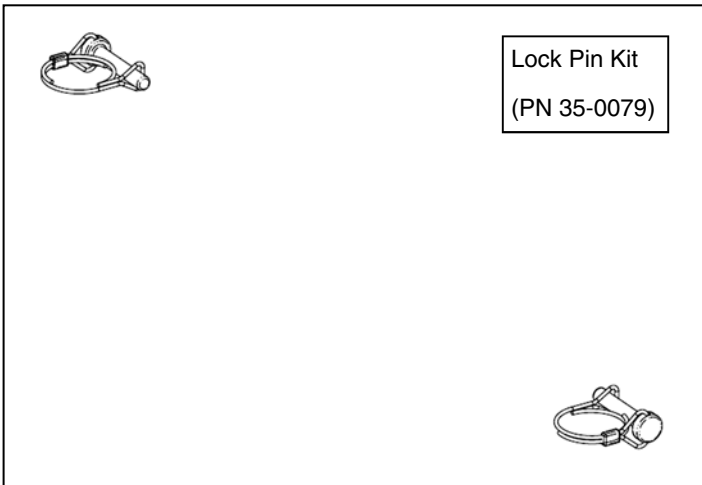
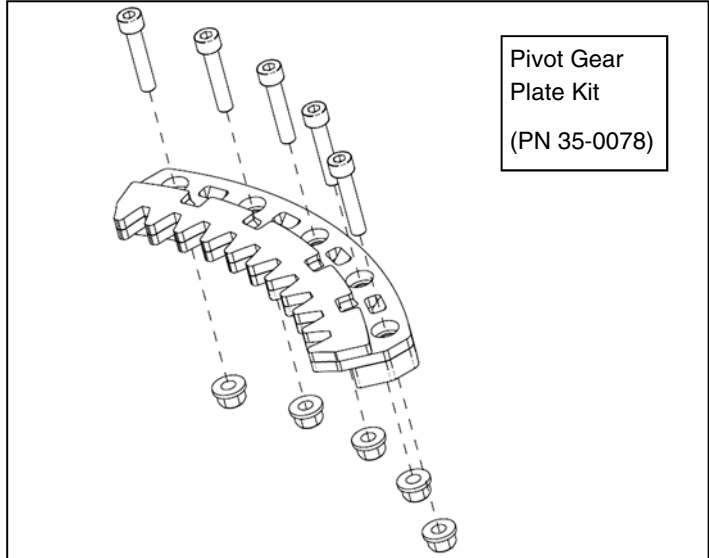
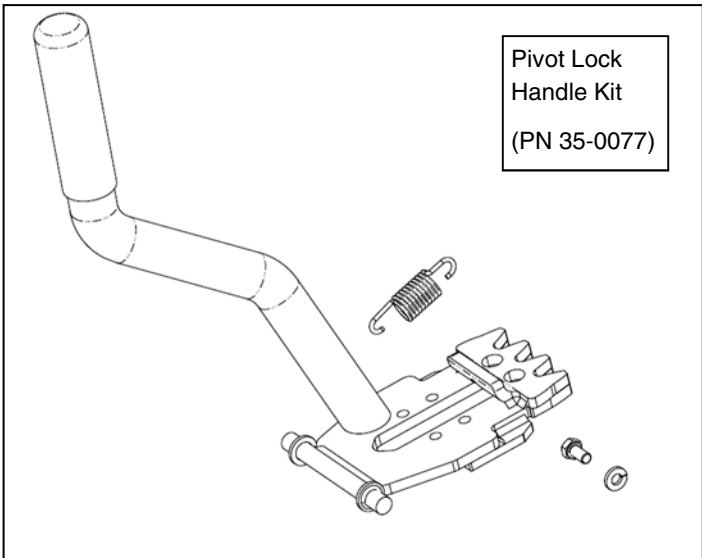
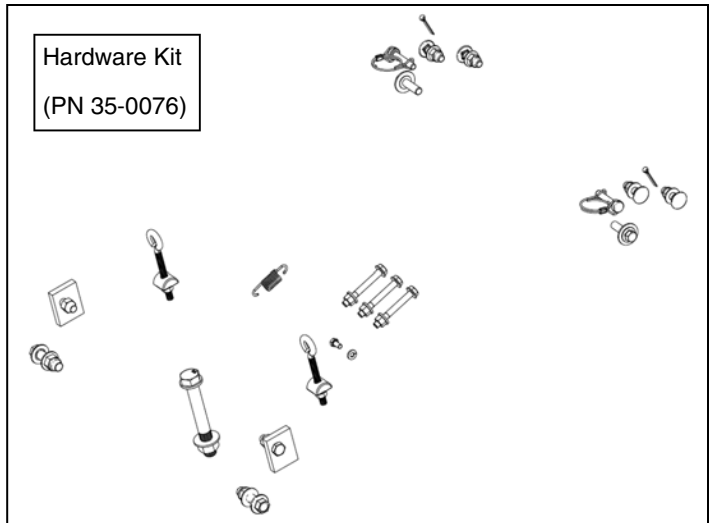
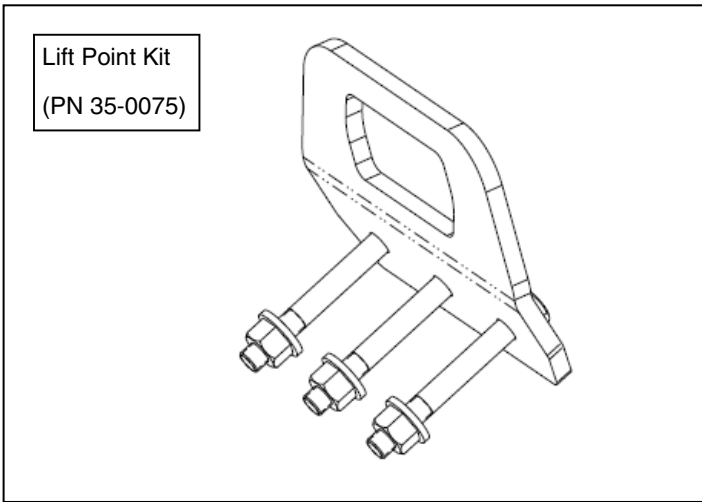

## OPERATION INSTRUCTIONS

### PIVOTING BLADE ANGLE SIDE TO SIDE

1. To adjust the angle of the plow blade so it pushes to the side, lift the plow up with the lift mechanism to clear the ground. Pull the pivot lock handle towards the blade and swivel the plow to desired angle. Release the pivot lock handle and the plow will lock itself in place at a predetermined angle on either side. (See illustration 2-1).
2. Be sure to frequently check that the (5) fasteners of the gear lock assembly are always tight to ensure good system function. (See illustration 2-2).
3. It is possible to adjust the clearance between the blade position lever and the blade position gear locking plate. Loosen the (5) bolts and move forward or backward the blade position gear locking plate. (See illustration 2-3).

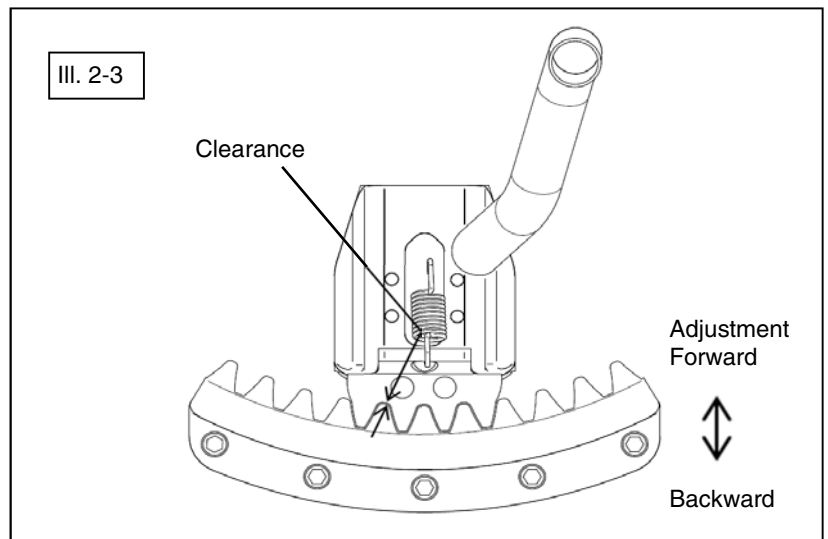
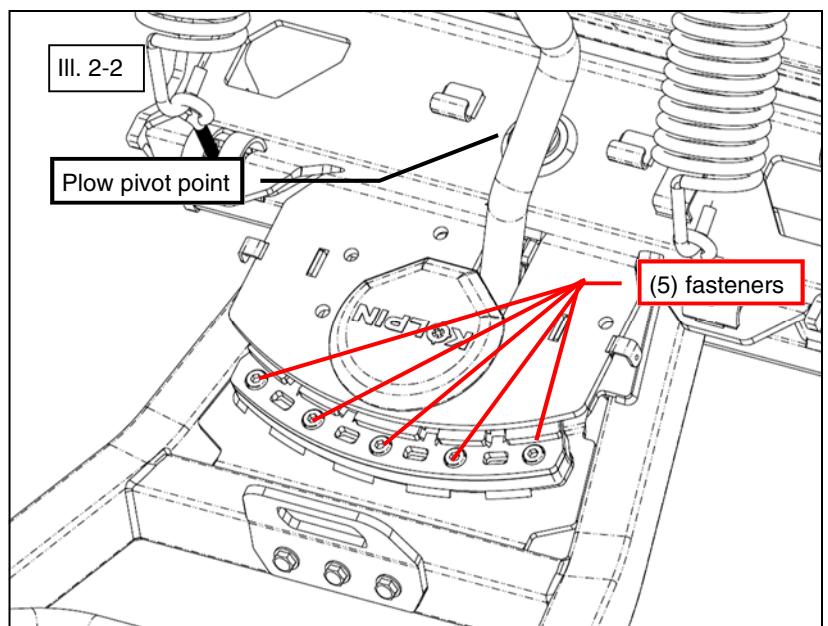
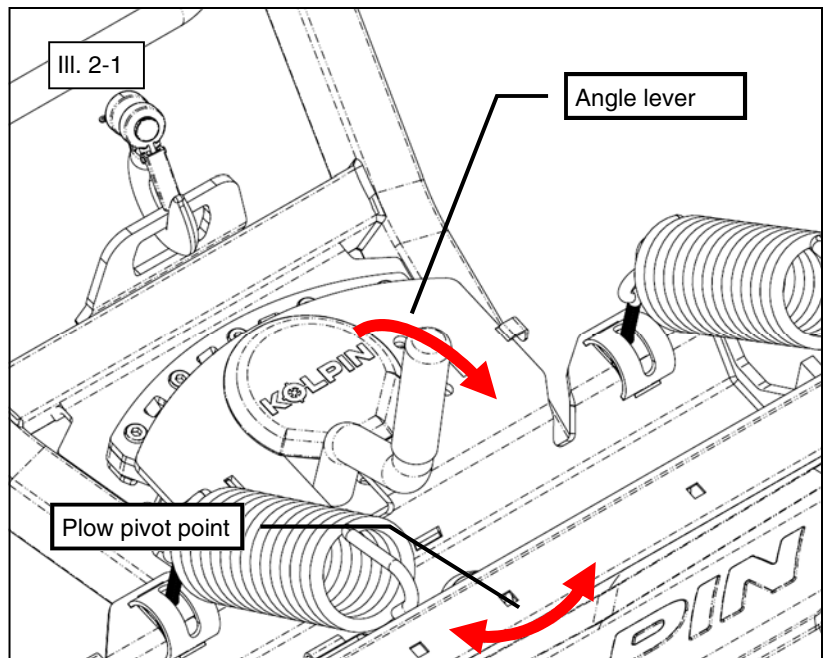

## OPERATION INSTRUCTIONS

### SCRAPING ANGLE ADJUSTMENT

4. Turn adjustable plow stoppers to one of the four positions in order to make the plow more aggressive or less aggressive. More aggressive will scrape better. Less aggressive will create more snow lift. Position 1 is the position with less material. (See illustrations 2-4 and 2-5).

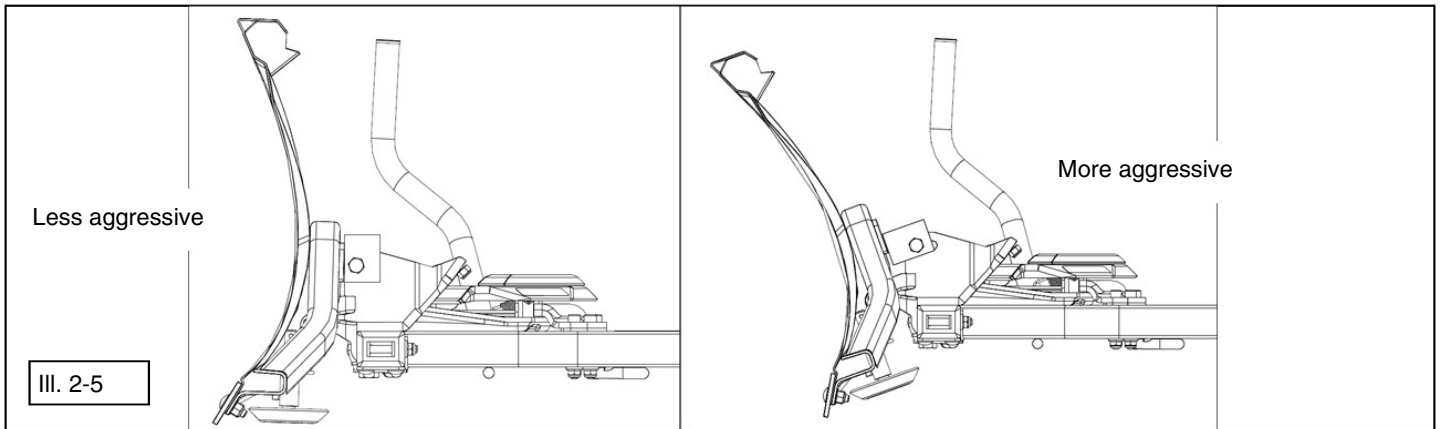
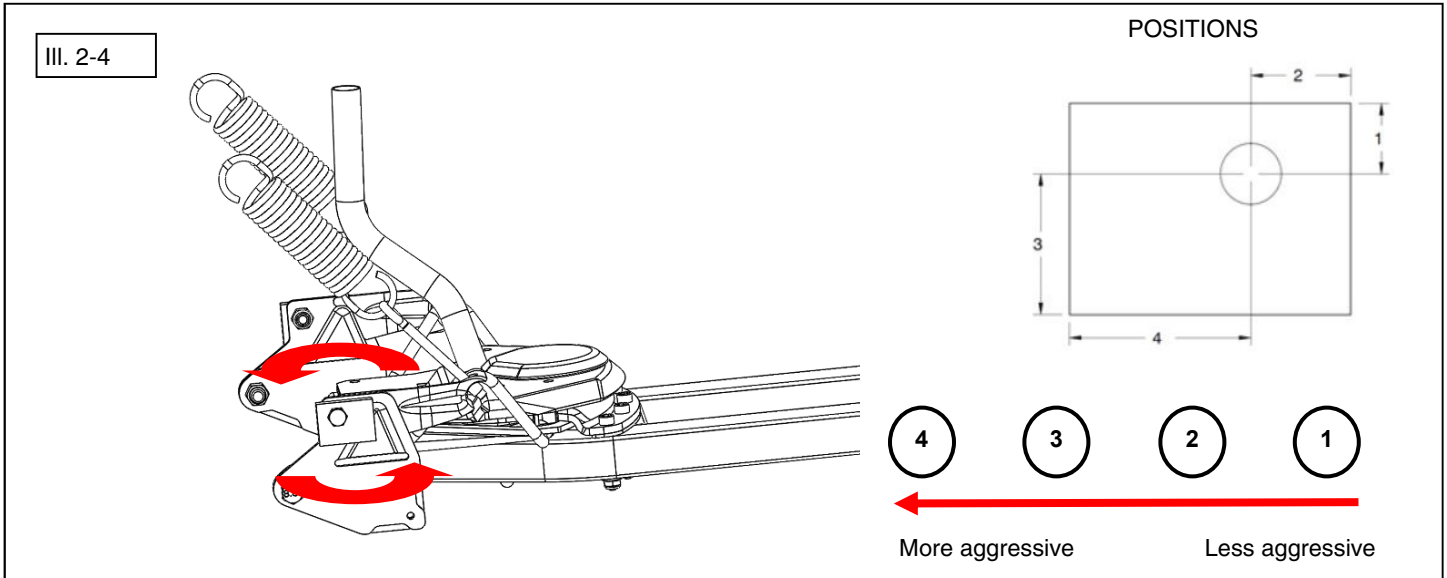

### BLADE TRIP HINGE FUNCTION

5. The plow is designed to trip forward when it hits a solid object. When the pressure on the plow is released, it will return to its original position by itself. (See illustration 2-6).

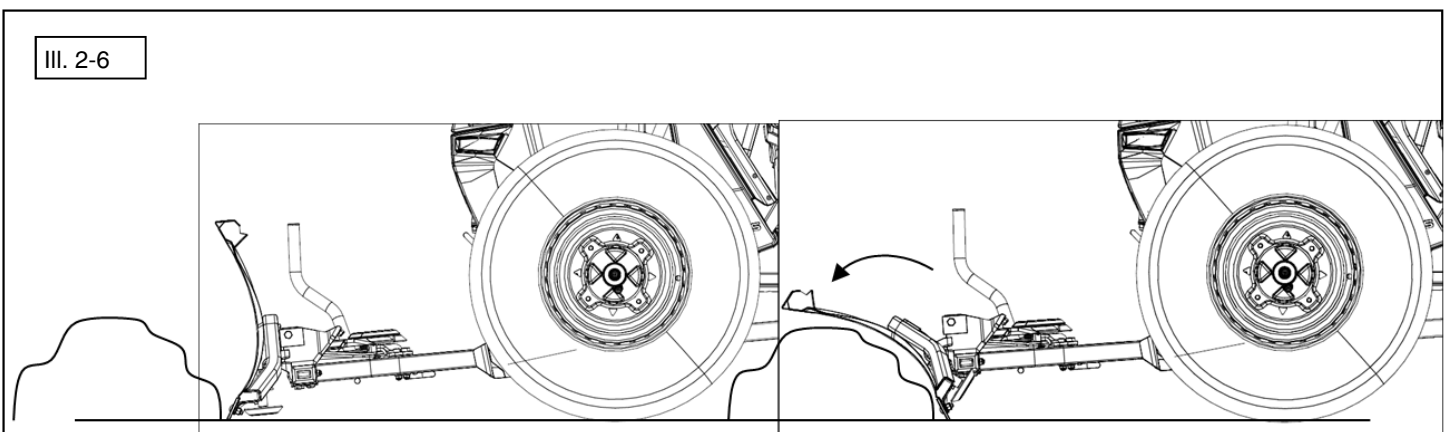

## OPERATION INSTRUCTIONS

### PLOW TRIPPING FORCE ADJUSTMENT

- The plow trip springs may be set stiffer by tightening the self-locking nuts located at the ends of the eye bolts. For less tension, loosen the nuts. (See illustration 2-7).

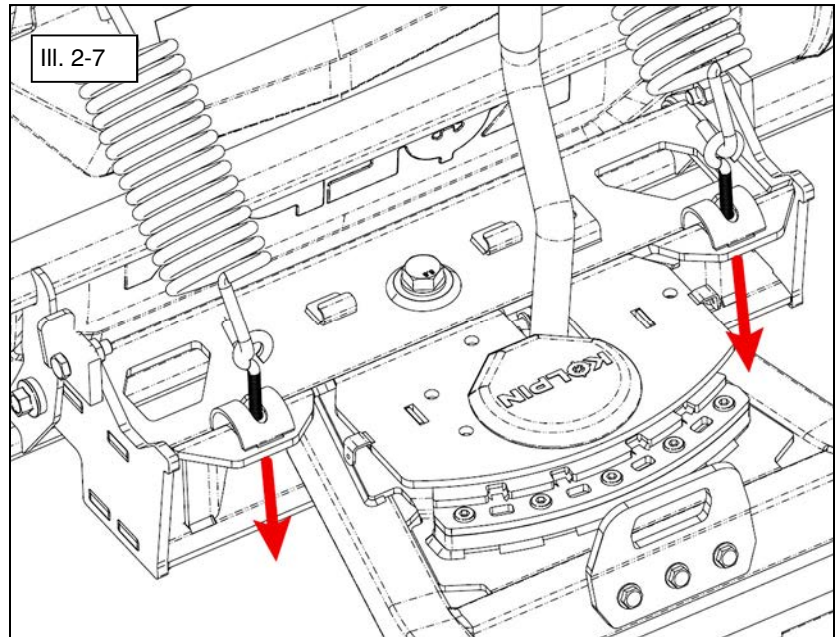

### PLOW IMPACT SHEAR POINTS

- In the event of a collision with an obstacle at a speed greater than that recommended for the system, the pivot lock handle (item #3) and/or pivot lock gear plate (item #4) will break to minimize the force of impact in the frame. If the pivot lock handle and/or pivot lock gear plate is broken, inspect the plow system for broken parts. If any part is damaged, the impact velocity was greater than what the system is designed to support. You must then buy a replacement part from your dealer and/or Kolpin customer care. (See illustration 2-8).

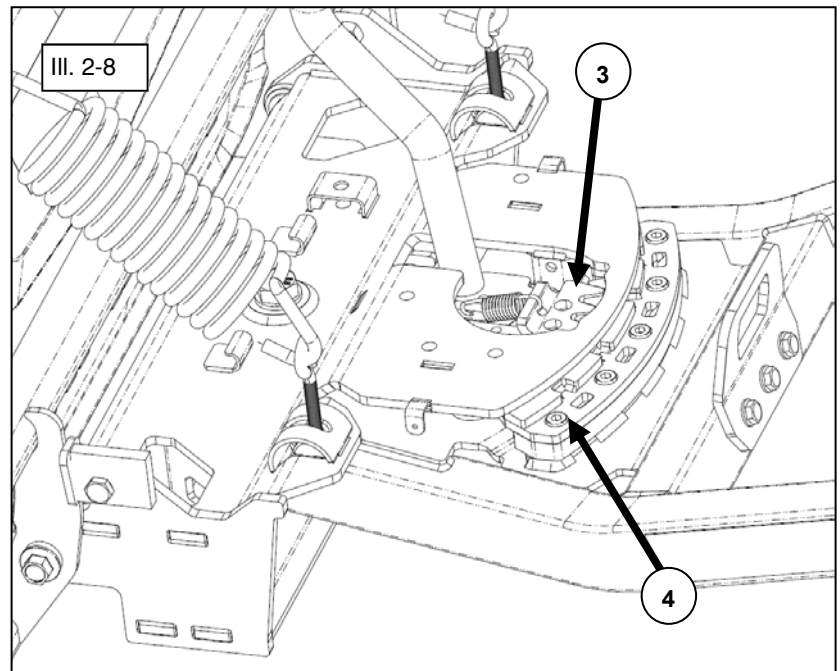

## OPERATION INSTRUCTIONS

### VEHICLE GROUND HEIGHT ADJUSTMENT

- The plow frame has built-in ground height adjustment tabs for the connection latch assembly. For vehicles that have larger tires or higher ground clearances, the connection latch can be adjusted into the middle position as shown. Adjusting the connection latch will help keep the plow level for higher ground clearances, example 28" - 29" tire sizes. (See illustration 2-9). **Note, refer to installation step 6 for details. The side brackets will be installed into the middle position.**
- For extra tall vehicles, example 30" or larger tire sizes, adjust the connection latch assembly into the highest position. (See illustration 2-10). **Note, refer to installation step 6 for details. The side brackets will be installed into the tallest position.**

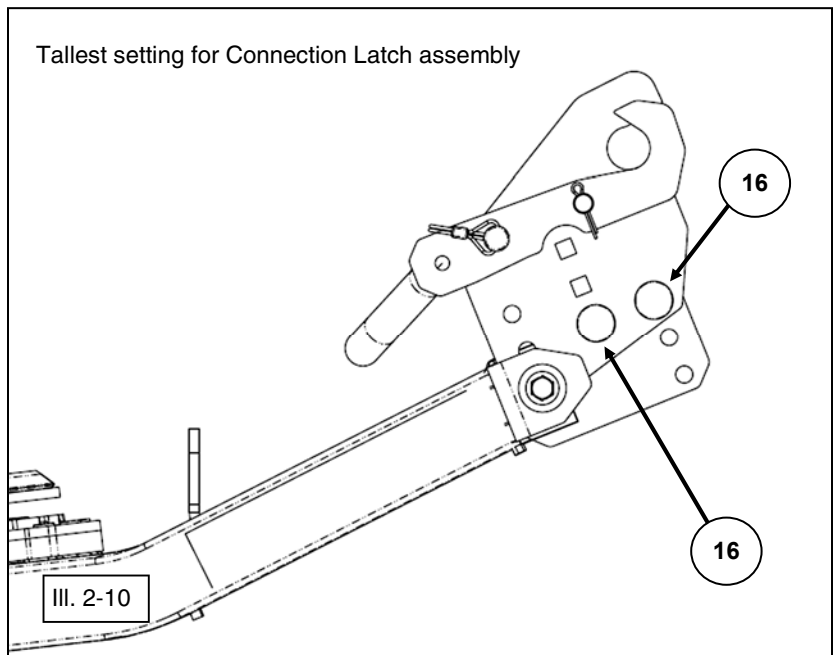
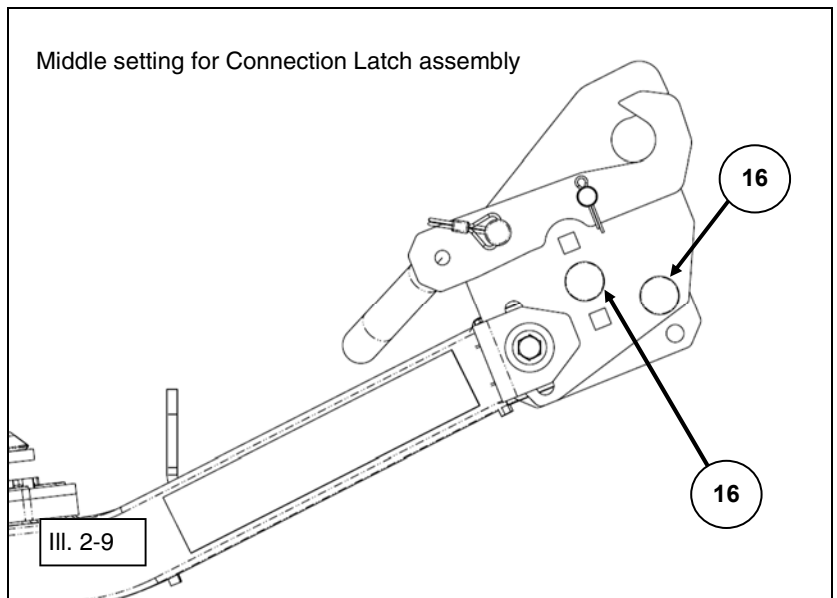



## Two Year Limited Warranty

For the period of two (2) years from the purchase date, Kolpin will replace for the original purchaser, free of charge, any part or parts found upon examination by Kolpin to be defective in material, workmanship, or both.

All transportation costs incurred submitting product to Kolpin for warranty consideration must be borne by the purchaser. If Kolpin determines that the product must be returned to the factory for credit, please call 1-877-956-5746 for a Return Merchandise Authorization (RMA) number and shipping instructions.

This warranty does not apply to parts that have been damaged by accident, alteration, abuse, improper maintenance, normal wear, or other causes beyond the manufacturer's control. In order to protect you and your ATV, certain parts of the plow system and/or hardware are designed to fail when the equipment is over-stressed. Parts that are lost due to loosening and improper maintenance are not covered under warranty. This warranty does not cover removal or reinstallation labor fees of the plow system and related components.

Peripheral products such as engines, electric motors, and actuators may carry an original manufacturer's warranty. Most hardware is general in nature and is easily obtained locally. Be sure to replace with minimum metric class 8.8 specification.

**Kolpin Outdoors, Inc.**

**Telephone: (763)-478-5800**

**Toll Free: (877)-956-5746**

**Fax Number: (800)-245-7569**

**[www.kolpin.com](http://www.kolpin.com)**

**Email: [customerservice@kolpin.com](mailto:customerservice@kolpin.com)**



# UTV CONQUEROR FRONT-CONNECT TRACKED VEHICLE PLOW EXTENSION

P/N 35-0350

## OWNER'S MANUAL

### Application

UTV CONQUEROR FRONT-CONNECT PLOW FRAME NO. 35-0070

**ATTENTION DEALER: CUSTOMER MUST RECEIVE A COPY OF THIS MANUAL  
AT THE TIME OF SALE.**

Before you begin, please read these instructions and check to be sure all parts and tools are accounted for. These instructions will help you to become familiar with operation of the plow push frame. Instructions contain details required to install, service the contents of this kit, for adjustment and maintenance.

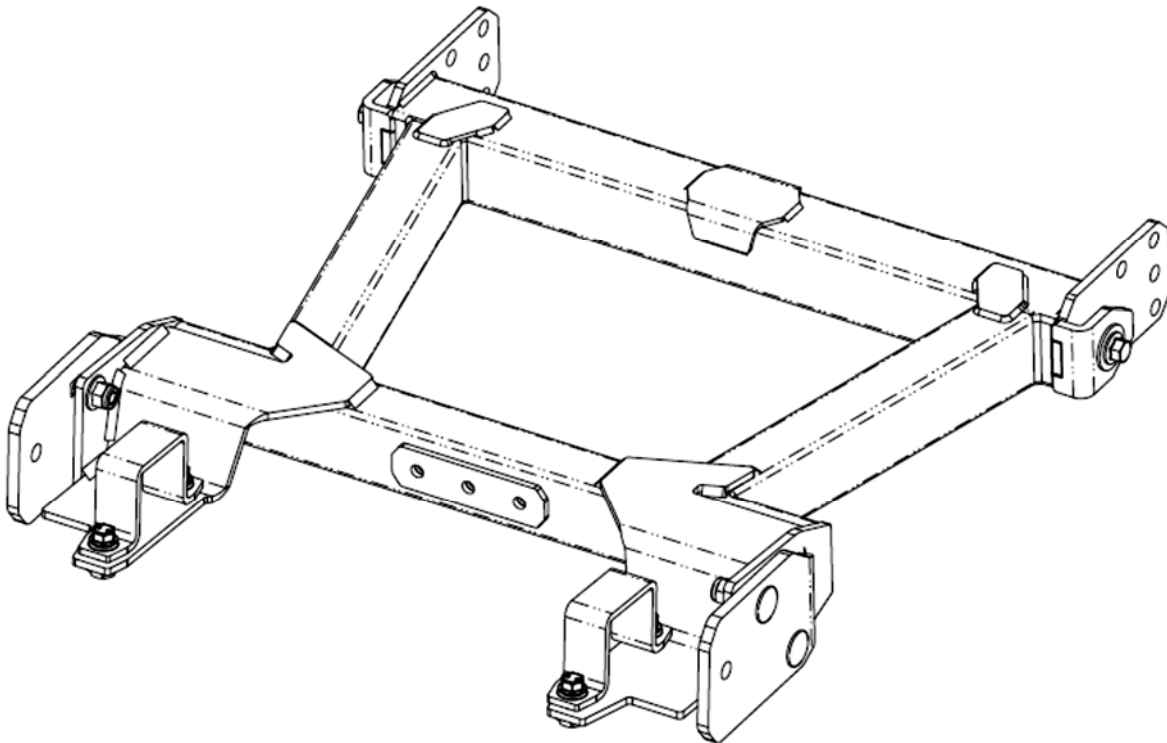



## INTRO

Thank you for purchasing Kolpin engineered products. With proper installation, usage, care, and maintenance, your Kolpin product will last for years to come.

## BEFORE YOU BEGIN

- Your Kolpin accessory is exclusively designed for your vehicle.
- Read and understand the entire installation manual, including all installation instructions, operating instructions, safety warnings and guidelines before installing or operating your accessory. Failure to comply may result in damage to the product and / or vehicle, and can lead to hazards up to and including death.
- Verify all parts and tools are accounted for. If parts are missing, do not return to the store. Call us for help, **Toll Free 1-877-956- 5746**
- Follow all steps correctly and in the sequence described.
- Keep these instructions for future reference or for informational requests.
- To facilitate installation, make sure that your vehicle is clean and free of debris.
- All directions referring to right and left are from the rider perspective when sitting on the machine.

## ASSEMBLY TIME

Approximately 24 minutes

## SAFETY INFORMATION

Please read and understand all Cautions, Notices, and Warnings in this manual before you begin. In order to protect you and your ATV / UTV, certain parts of the plow system and / or hardware are designed to fail when the equipment is overstressed.

### **Follow these guidelines to ensure satisfactory operation:**

- Read this manual and your ATV / UTV operators manual before use.
- Periodically check for wear and tightness of all fasteners. Replace or re-torque fasteners as necessary.
- Before first use, set plow in the furthest right or left angled position to check for interference with the vehicle.
- Operate with extreme caution on slopes and rough terrain. Be familiar with the area before you plow.
- Be aware of immovable objects that could be hidden in the area you are plowing.
- To avoid damage when pushing snow into a pile, reverse direction before raising the plow blade.
- Do not ram the plow blade into piles of snow.
- For best results, set the suspension preload of your ATV / UTV to the stiffest setting.
- To reduce steering effort and increase mobility, set the air pressure of your tires to the maximum pressure specification.
- The plow skids are adjustable. General skid setting is even with the plow wear bar bottom edge, higher settings reduce the chance of rocks and gravel from being collected.
- To increase traction during plow operation, operators can try: Securing weight to the ATV / UTV for additional tire downforce, reducing tire air pressure, or installing tire chains.





## WARNING



### TO AVOID SERIOUS INJURY OR DEATH:

1. DO NOT EXCEED 5 MPH (8 KMH) WITH BLADE INSTALLED
2. OPERATE WITH EXTREME CAUTION ON SLOPES, STEEP GRADES, AND ROUGH TERRAIN
3. ALLOW NO RIDERS ON BLADE OR ATV WHILE MOVING OR STATIONARY
4. KEEP BYSTANDERS AWAY FROM THE BLADE OR ATV WHILE MOVING OR STATIONARY
5. WHEN PUSHING HEAVY MATERIAL, DIRECTION CONTROL MAY BECOME DIFFICULT
6. BEFORE ADJUSTING BLADE: STOP ATV ENGINE; SET AND LOCK BRAKES; RAISE AND LOCK BLADE
7. LOWER BLADE TO DOWN POSITION WHEN BLADE AND ATV ARE NOT IN USE
8. READ BLADE INSTRUCTION SHEETS AND ATV OWNER'S MANUAL

## REQUIRED SOLD SEPARATELY

Only parts for installation of the Plow Push Frame Kit are included. For complete snow plow system installation, additional items are required such as a plow blade, plow frame, vehicle plow mount, winch, and winch mount. See [www.Kolpin.com](http://www.Kolpin.com) for products to complete your plow system.

## TOOLS REQUIRED

- Safety Glasses
- Socket Set, Metric
- Torque Wrench
- Wrench Set, Metric

## IMPORTANT

The use of a Kolpin winch with the combination of Kolpin auto-stop and synthetic winch rope are recommended for use with this plow system to prevent premature failure of the winch cable. The winch should be installed on the unit prior to installing this kit.

# KIT CONTENTS

Item	Qty	Part Description	Part Number
1	2	Tube Clamp Bracket, Painted	-
2	1	Lift Point Tube Support, Painted	-
3	1	Plow Frame Extension	-
4	2	Hex Flange Screw, Zinc Plated, M10-1.5 x 35mm LG	-
5	4	Hex Flange Screw, Zinc Plated, M8-1.25 x 25mm LG	-
6	4	Hex Flange Locknut, Zinc Plated, M10-1.5	-
7	4	Lock Washer, Zinc Plated, M8	-
8	2	Flat Washer, Zinc Plated, M10	-
9	2	Lock Washer, Zinc Plated, M10	-
10	4	Flat Washer, Zinc Plated, M8	-
11	4	Carriage Screw, Zinc Plated, M10-1.5 x 35mm LG	-
12	1	Instruction Manual (not shown)	-

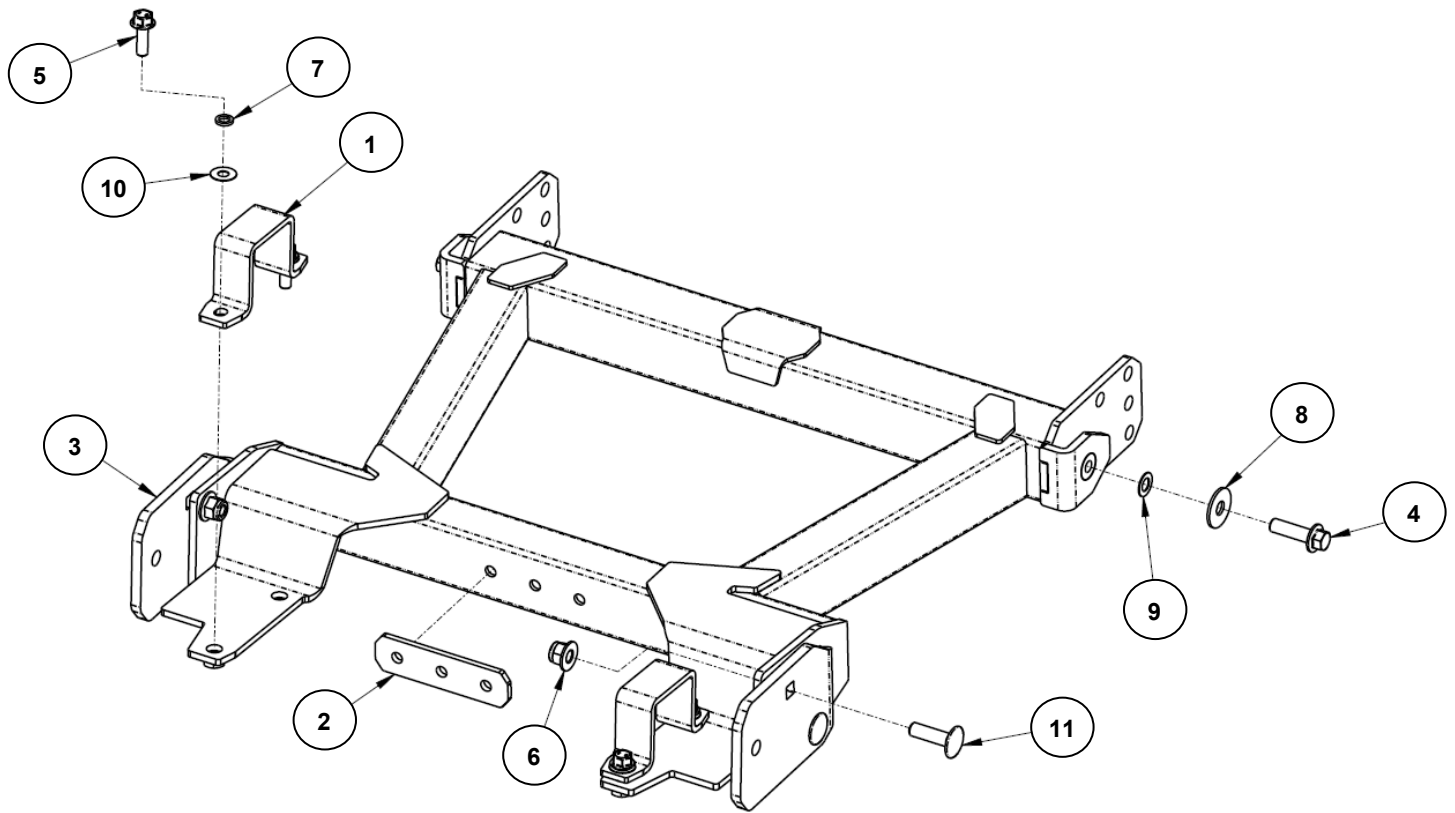



# INSTALLATION INSTRUCTIONS

## EXTENSION FRAME ASSEMBLY

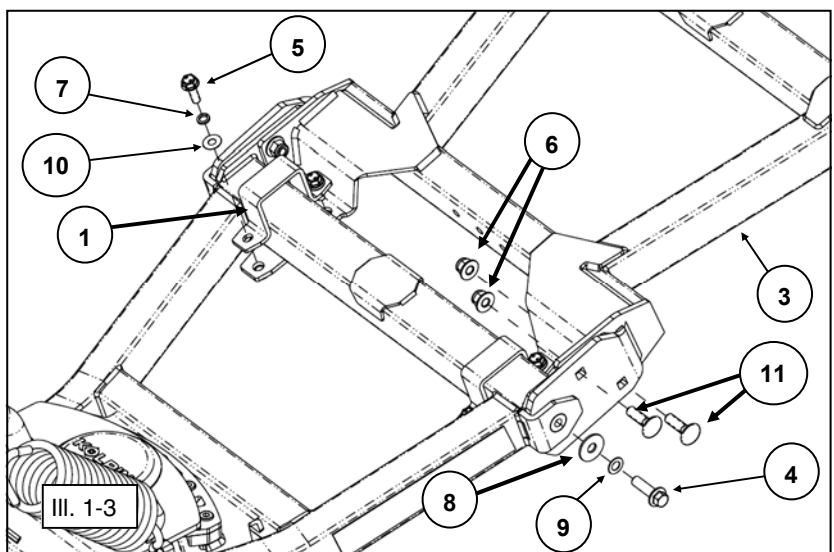
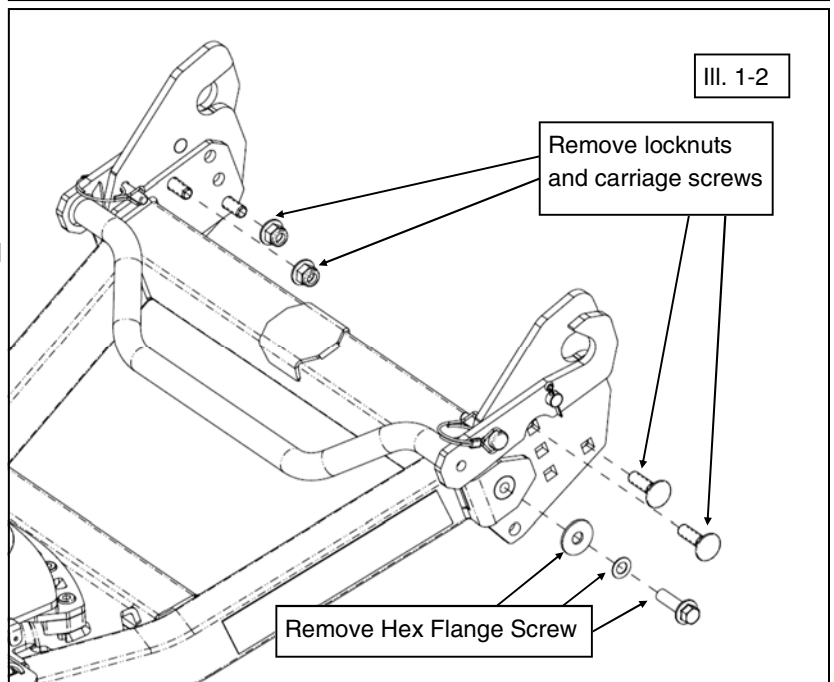
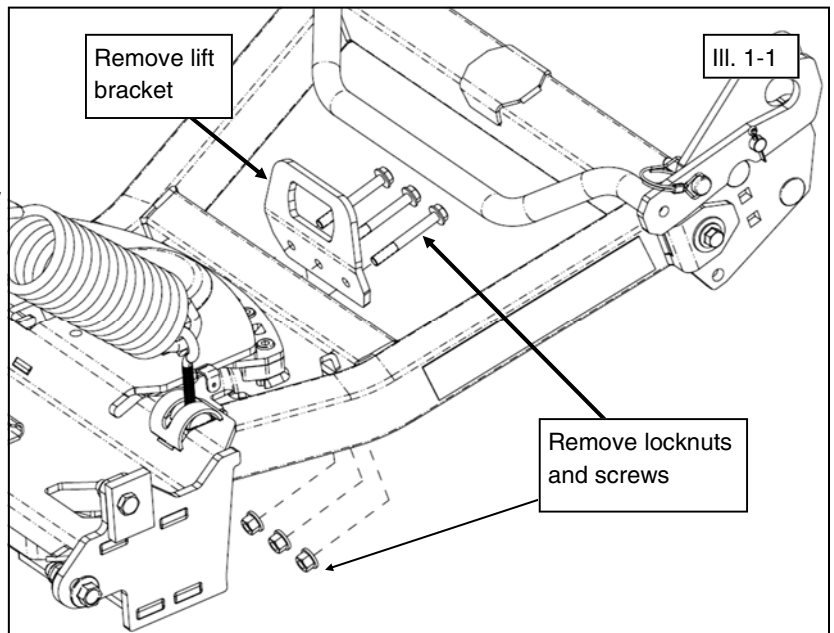
1. Remove the lift point bracket (bracket and three screws & locknuts) from the 35-0070 Plow Frame as shown. Keep the as these will be reinstalled onto the 35-0350 extension frame (item #3). (See illustration 1-1).
2. Remove the Connection Latch assembly (latch tube, two side plates, two M10 hex flange screws & washers, four M10 carriage screws & locknuts) from the 35-0070 Plow Frame as shown. Keep the items as these will be reinstalled onto the rear of 35-0350 extension frame (item #3). (See illustration 1-2). **Note, keep the cotter pin and safety wire lock pins installed with the Connection Latch assembly.**
3. Install Extension Frame (item #3) onto the rear of the 35-0070 Plow Frame as shown. Install the M10 carriage screws (item #11) through the Extension Frame and Plow Frame holes and fasten using M10 locknuts (item #6). Install the M10 hex flange screws (item #4) through M10 lock washer (item #9) and through M10 flat washer (item #8) and through the Plow Frame. (See illustration 1-3).
4. Install the tube frame clamp brackets (item #1) over the Plow Frame as shown. Fasten using M8 hex flange screws (item #5) through M8 lock washer (item #7) through M8 flat washer (item #10) and into the Extension Frame threaded tab. (See illustration 1-3).
5. Tighten all hardware to specifications.



 = T
<b>10MM FASTENER TORQUE:</b> 34 ft-lbs. (46 N-m)

 = T
<b>8MM FASTENER TORQUE:</b> 17 ft-lbs. (23 N-m)

## INSTALLATION INSTRUCTIONS

### EXTENSION FRAME ASSEMBLY (continued)

6. Install the Connection Latch Assembly onto the rear of the Extension Frame (item #3) as shown. Install using the M10 hardware removed in step 2 and tighten to M10 specifications. (See illustration 1-4). **Note, refer to 35-0070 Plow Frame install instructions for additional assistance.**
7. Install the lift point bracket onto the Extension Frame (item #3) as shown using the M8 hardware. Install the Tube Support Plate (item #2) under the locknuts. Tighten to M8 specifications. (See illustration 1-5). **Note, the lift point bracket can be installed on the rear of the extension tube as shown or on the front of the extension tube (not shown).**

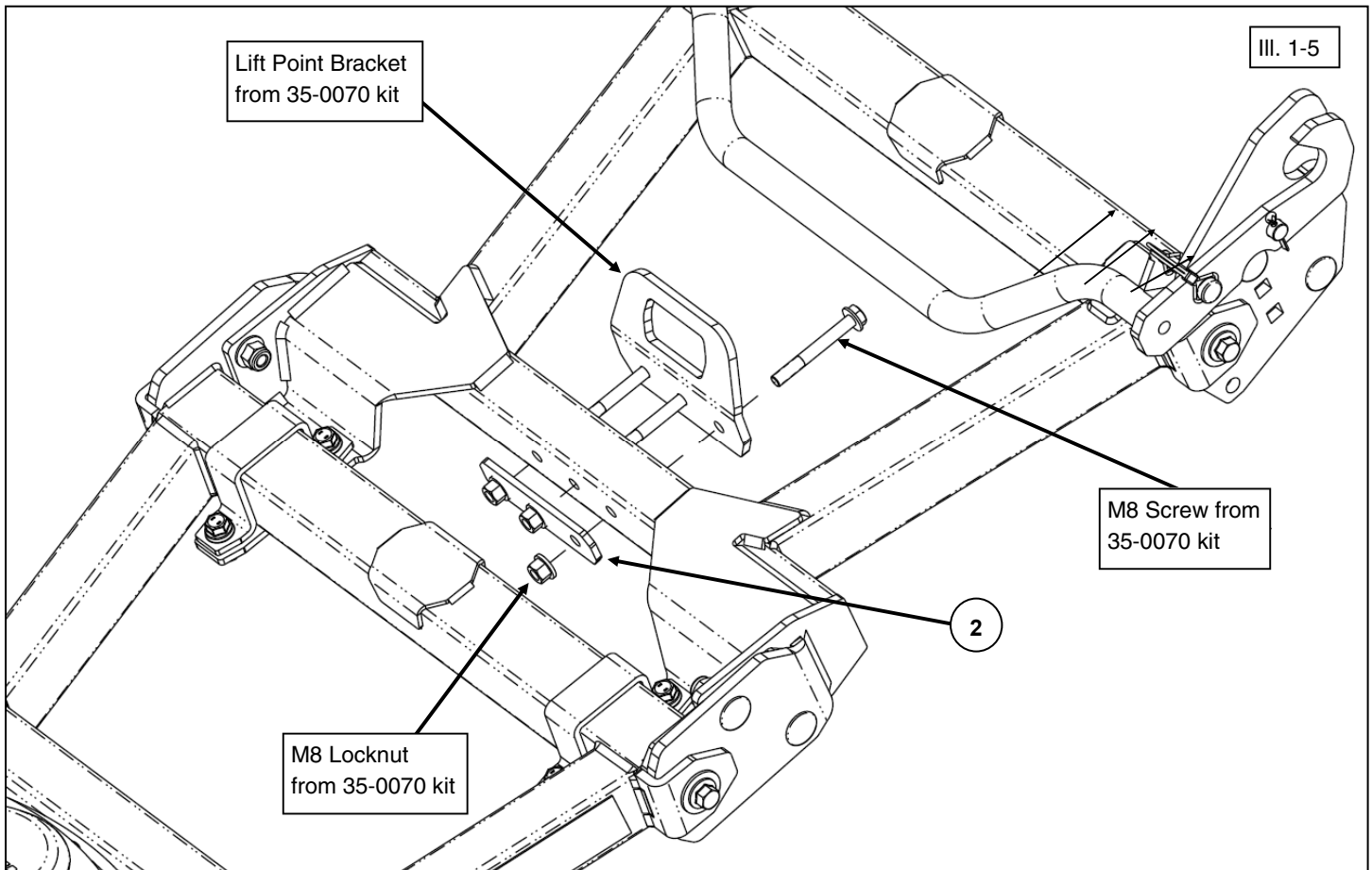
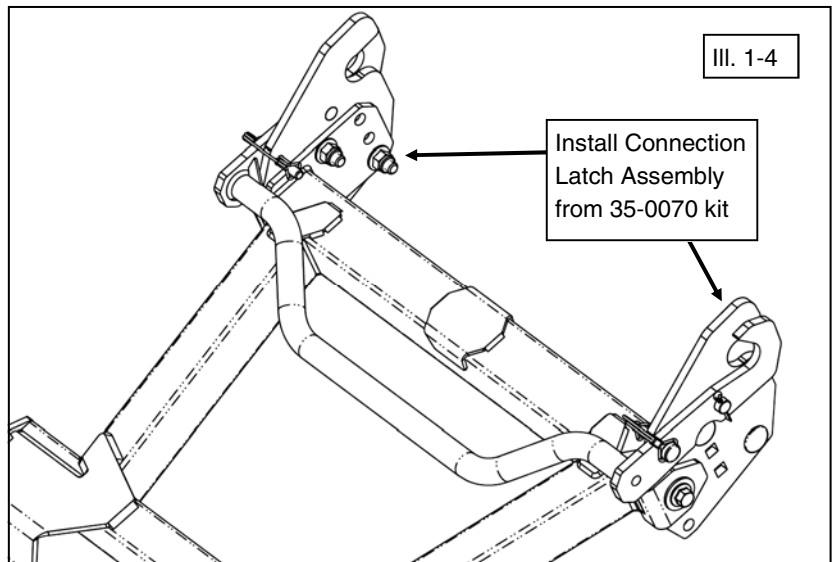



## **Two Year Limited Warranty**

For the period of two (2) years from the purchase date, Kolpin will replace for the original purchaser, free of charge, any part or parts found upon examination by Kolpin to be defective in material, workmanship, or both.

All transportation costs incurred submitting product to Kolpin for warranty consideration must be borne by the purchaser. If Kolpin determines that the product must be returned to the factory for credit, please call 1-877-956-5746 for a Return Merchandise Authorization (RMA) number and shipping instructions.

This warranty does not apply to parts that have been damaged by accident, alteration, abuse, improper maintenance, normal wear, or other causes beyond the manufacturer's control. In order to protect you and your ATV, certain parts of the plow system and/or hardware are designed to fail when the equipment is over-stressed. Parts that are lost due to loosening and improper maintenance are not covered under warranty. This warranty does not cover removal or reinstallation labor fees of the plow system and related components.

Peripheral products such as engines, electric motors, and actuators may carry an original manufacturer's warranty. Most hardware is general in nature and is easily obtained locally. Be sure to replace with minimum metric class 8.8 specification.

**Kolpin Outdoors, Inc.**

**Telephone: (763)-478-5800**

**Toll Free: (877)-956-5746**

**Fax Number: (800)-245-7569**

**[www.kolpin.com](http://www.kolpin.com)**

**Email: [customerservice@kolpin.com](mailto:customerservice@kolpin.com)**

# KOLPIN<sup>®</sup>

## OUTDOORS

# HIGH RISE POWER ANGLE KIT

P/N 33-0100

## OWNER'S MANUAL

Application

HIGH RISE PUSH TUBE 33-0000 & 34-0000

**ATTENTION DEALER: CUSTOMER MUST RECEIVE A COPY OF THIS MANUAL  
AT THE TIME OF SALE.**

Before you begin, please read these instructions and check to be sure all parts and tools are accounted for. These instructions will help you to become familiar with operation of the plow push frame. Instructions contain details required to install, service the contents of this kit, for adjustment and maintenance.

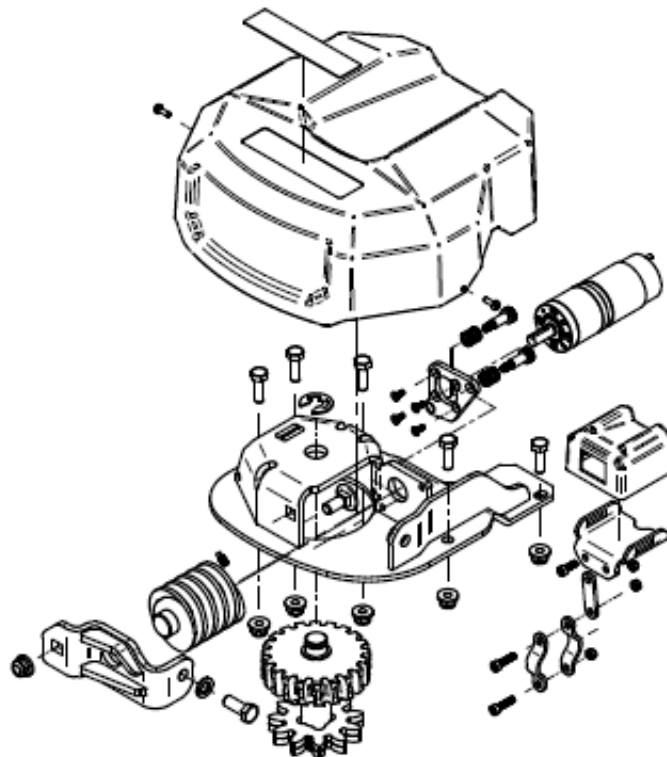

# OPERATING INSTRUCTIONS

Congratulations! You've just purchased one of the industry's top plow system component. The High Rise Power Angle works great for all types of plowing. With proper care and maintenance, your power angle kit will last for many years!

The power angle motor design allows the operator to select a finite range of angled left-or-right blade positions while sitting on the ATV. The heavy-duty gear system is designed to absorb the impact loading during normal operation. Once installed, the power angle kit will remain on the High Rise push frame and includes a wire disconnect terminal. Additionally, this power angle will handle light to medium-duty summer landscape work in moderate climates.

## NOTICE

**Plow operation requires additional components for operation:  
*Kolpin Snow Plow Blade, High Rise Push Frame, Winch Kit, Mid-Body Plow Mount \****

*\*These components may be specific to your vehicle.*



Please read and understand all assembly instructions, notices and warnings before assembling and operating your High Rise Power Angle plow system.

### Follow these guidelines to ensure satisfactory operation:

- Read this manual and your ATV operators manual before use.
- Periodically check for wear and tightness of all fasteners. Replace or re-torque fasteners as necessary.
- Before first use, set plow in the furthest right or left angled position to check for clearance between the plow and front tires.
- Do not operate angling kit in temperatures above 65°F (18°C) or below -20°F (-28°C).
- *The Power Angle motor provides enough torque to pivot when blade is in lifted position only. **Do not pivot system when blade is resting on the ground. Damage may result.***
- *Once the plow is not turning anymore (due to an obstacle or being locked in the furthest angle position on either side), release the switch.*
- ***Do not keep operating the angling kit when the plow is locked. Damage may result.***
- Operate with extreme caution on slopes and rough terrain. Be familiar with the area before you plow.
- Be aware of immovable objects that could be hidden in the area you are plowing.
- To avoid damage when pushing snow into a pile, reverse direction before raising the plow blade.
- Do not ram the plow blade into piles of snow. **\*\*Slow down before hitting a pile.\*\***
- For best results, set the suspension preload of your ATV to the stiffest setting.
- To reduce steering effort and increase mobility, set the air pressure of your tires to the maximum pressure specification.
- The plow skids are adjustable. General skid setting is even with the plow wear bar bottom edge, higher settings reduce the chance of rocks and gravel from being collected.
- To increase traction during plow operation, operators can try: Securing weight to the ATV for additional tire downforce, reducing tire air pressure, or installing tire chains.
- The plow blade assembly is designed to 'trip' when it strikes an object or digs in too far. When pressure is released, the plow springs back into position. ***Spring tension can be increased by tightening the locknuts on the bottom of the eyebolts. For less spring tension, loosen the locknuts.***
- Always wear appropriate protective clothing as recommended in ATV's operator's manual.
- Keep away from blade and moving parts during operation.

## SAFETY INFORMATION

Our plow systems were designed with your safety in mind. Please read and understand all Cautions, Notices and Warnings in this manual before you begin. In order to protect you and your ATV, certain parts of the plow system and/or hardware are designed to fail when the equipment is over-stressed.

 **WARNING** 

**TO AVOID SERIOUS INJURY OR DEATH:**

1. **DO NOT EXCEED 5 MPH (8 KMH) WITH BLADE INSTALLED**
2. **OPERATE WITH EXTREME CAUTION ON SLOPES, STEEP GRADES, AND ROUGH TERRAIN**
3. **ALLOW NO RIDERS ON BLADE OR ATV WHILE MOVING OR STATIONARY**
4. **KEEP BYSTANDERS AWAY FROM THE BLADE OR ATV WHILE MOVING OR STATIONARY**
5. **WHEN PUSHING HEAVY MATERIAL, DIRECTION CONTROL MAY BECOME DIFFICULT**
6. **BEFORE ADJUSTING BLADE: STOP ATV ENGINE; SET AND LOCK BRAKES; RAISE AND LOCK BLADE**
7. **LOWER BLADE TO DOWN POSITION WHEN BLADE AND ATV ARE NOT IN USE**
8. **READ BLADE INSTRUCTION SHEETS AND ATV OWNER'S MANUAL**

### BEFORE YOU BEGIN:

- Your Kolpin accessory is exclusively designed for your vehicle.
- Please read and understand all instructions.
- Verify all parts and tools are accounted for.
- To ensure a satisfactory installation, follow all steps correctly and in the sequence described.
- Keep these instructions for future reference or for informational requests.
- To facilitate installation, make sure that your vehicle is clean and free of debris.
- All directions referring to right and left are when the rider is sitting on the machine

### TOOLS REQUIRED:

- 10mm wrench
- 8mm wrench or 8mm socket
- 13mm wrench and 13mm socket
- 4mm allen key wrench
- Long nose pliers or spring puller or shoe-string sized rope
- For UTV installations only, plastic cutting tool (Dremel tool or drill bit)

## APPROXIMATE ASSEMBLY TIME: 30 minutes

Note: The High Rise Power Angle kit comes mostly assembled from factory. Some assembly is required.

**RE-TORQUE ALL BOLTS AND NUTS AFTER THE FIRST 30 MINUTES OF USE.**



## Kit Contents:

Item	Qty	Part Description	Part Number
1	13	Cable Tie, 141mm long	-
2	1	Carriage Bolt, Zinc Plated, M10-1.5 x 25mm	-
3	1	Circlip, Zinc Plated	-
4	4	Flat Socket Head Cap Screw, Zinc Plated, M4-0.7 x 10mm	-
5	1	Set Screw, Zinc Plated, M6-1.0 x 12mm	-
6	1	Hex Bolt, Zinc Plated, M10-1.5 x 25mm	-
7	5	Hex Bolt, Zinc Plated, M8-1.25 x 25mm	-
8	3	Hex Nylon Nut, Zinc Plated, M5-0.8	-
9	1	Lock Washer, Zinc Plated, M10	-
10	1	Nylon Flange Nut, Zinc Plated, M10-1.5	-
11	5	Nylon Flange Nut, Zinc Plated, M8-1.25	-
12	2	Shoulder Screw, Zinc Plated, Dia. 8mm x 14mm, M6-1.0	-
13	1	Socket Head Cap Screw, Zinc Plated, M5-0.8 x 14mm LG	-
14	2	Socket Head Cap Screw, Zinc Plated, M5-0.8 x 20mm LG	-
15	1	Gear Assembly, Zinc Plated	-
16	2	Handlebar Clamp, Painted	-
17	1	Straight Section Bracket, Painted	-
18	1	Switch Bracket, Painted	-
19	1	Plastic Handlebar Switch Cap	-
20	1	Welded Frame Assembly, Zinc Plated	-
21	1	Wiring Harness Assembly (motor side)	-
22	1	Plate Assembly, Zinc Plated	-
23	1	ATV/UTV Wiring Harness with Switch and Fuse (vehicle side)	-
24	1	Worm Gear, Zinc Plated	-
25	1	Plastic Motor Cap	33-0120
26	1	Decal	-
27	2	Spring	-
28	1	Motor Mounting Plate, Zinc Plated	-
29	1	Electric Motor	33-0111
30	2	Self-Tapping Screw, Zinc Plated, M4-0.7 x 12mm LG	-
31	1	Instruction Guide (not shown)	-

# Kit Contents (continued):

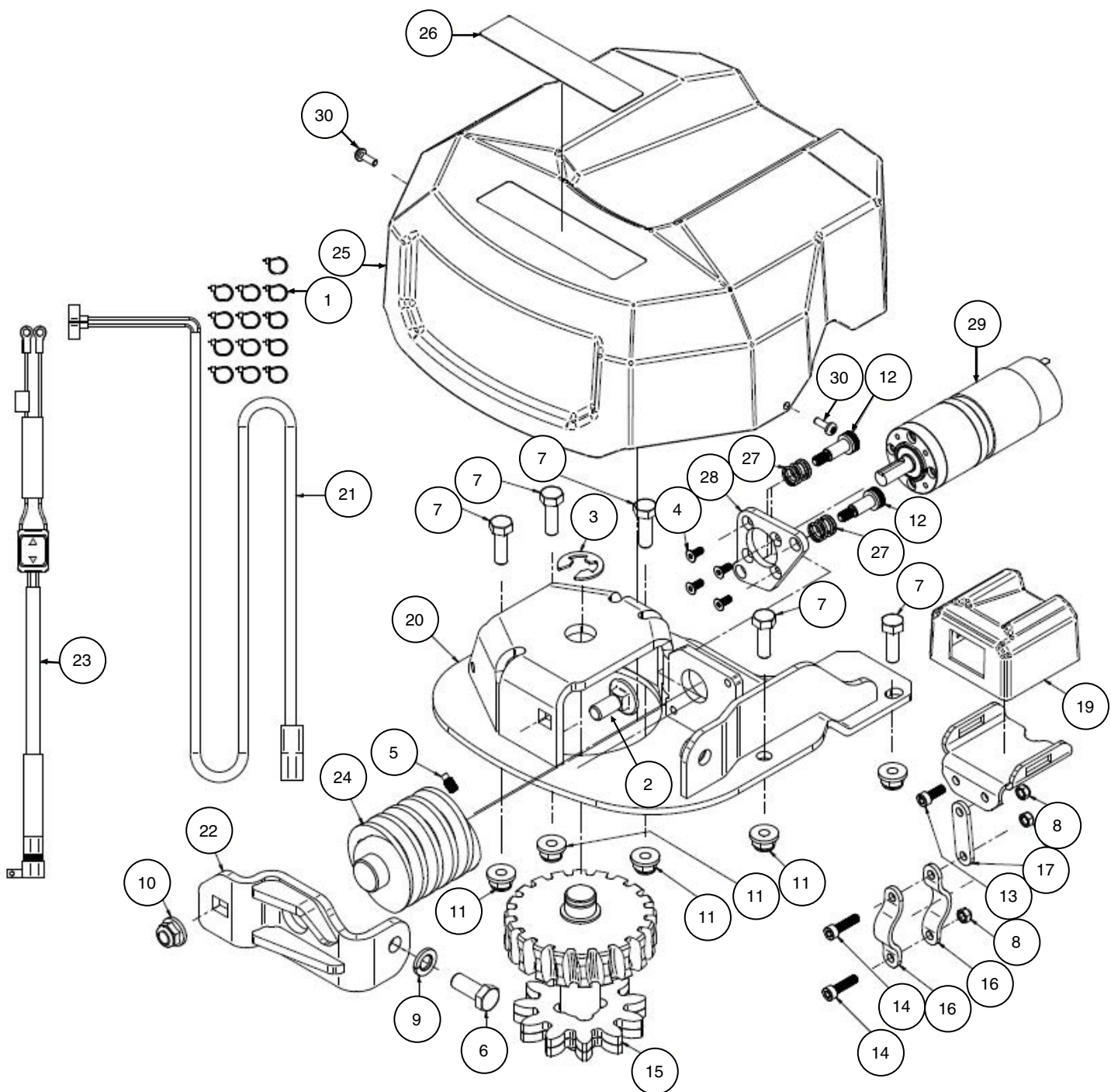

## ASSEMBLY INSTRUCTIONS:

### INSTALLATION PREP:

1. Remove the plastic cap from the push frame. Remove the spring and the screw securing the angling arm as shown. Using a rope or a spring puller to pull on the higher side allows for easy removal of spring. (See illustration 1-1).

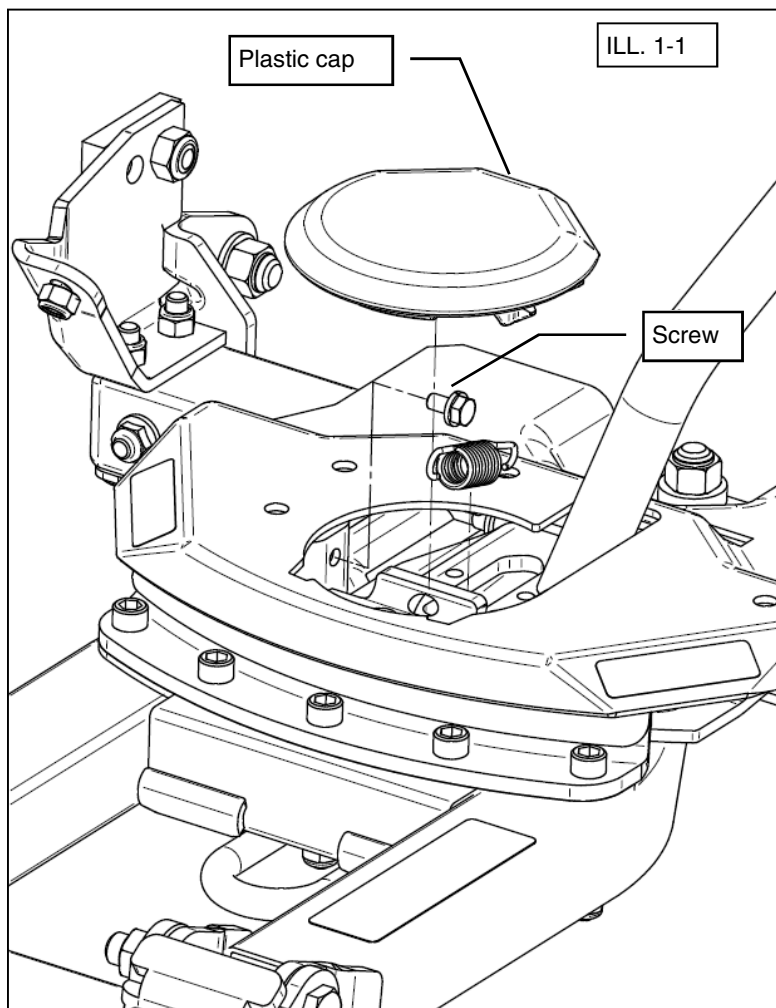

2. Tilt the angling arm up toward the blade, then pull it toward the ATV. The arm will come out of push frame. (See illustration 1-2).

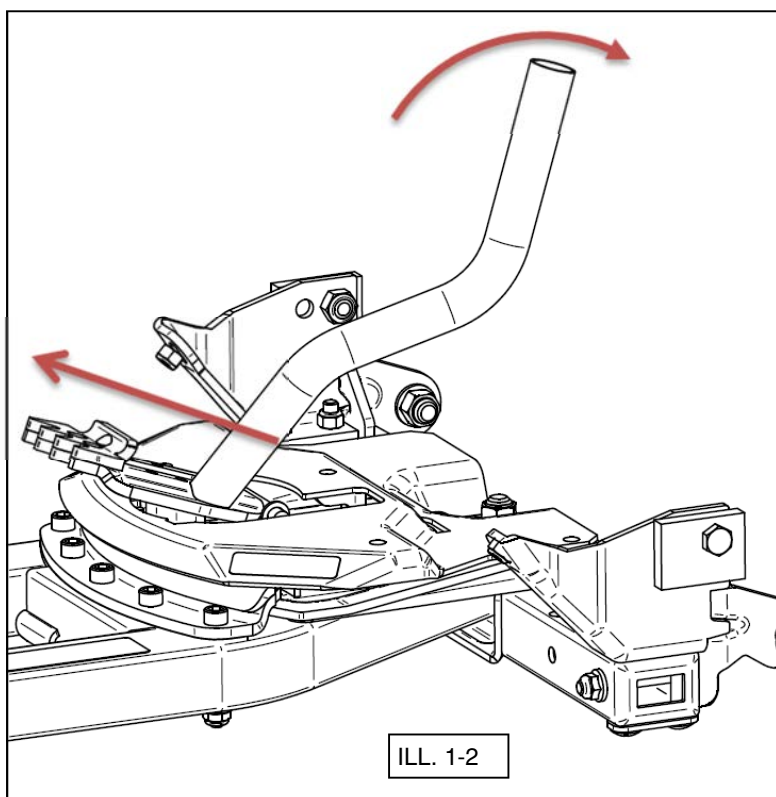

## POWER ANGLE INSTALLATION ONTO PUSH FRAME ASSEMBLY:

1. Position the power angle motor frame assembly onto the push frame as shown. The hole (see illustration 2.2) in the push frame pivot assembly serves as bottom alignment guide for the gear assembly. Insert the five bolts, item #7, thru the power angle frame holes and push frame holes. Fasten the five flanged M8 nylon nuts, item # 11, onto bolts. Tighten to specification. (See illustration 2-1).

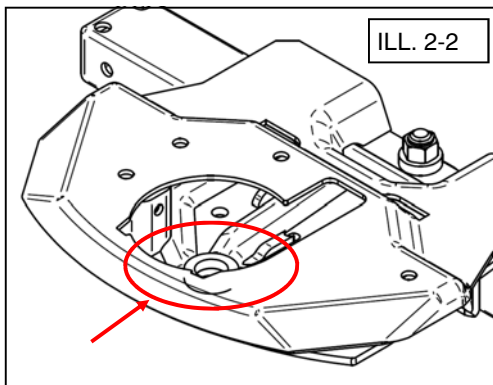
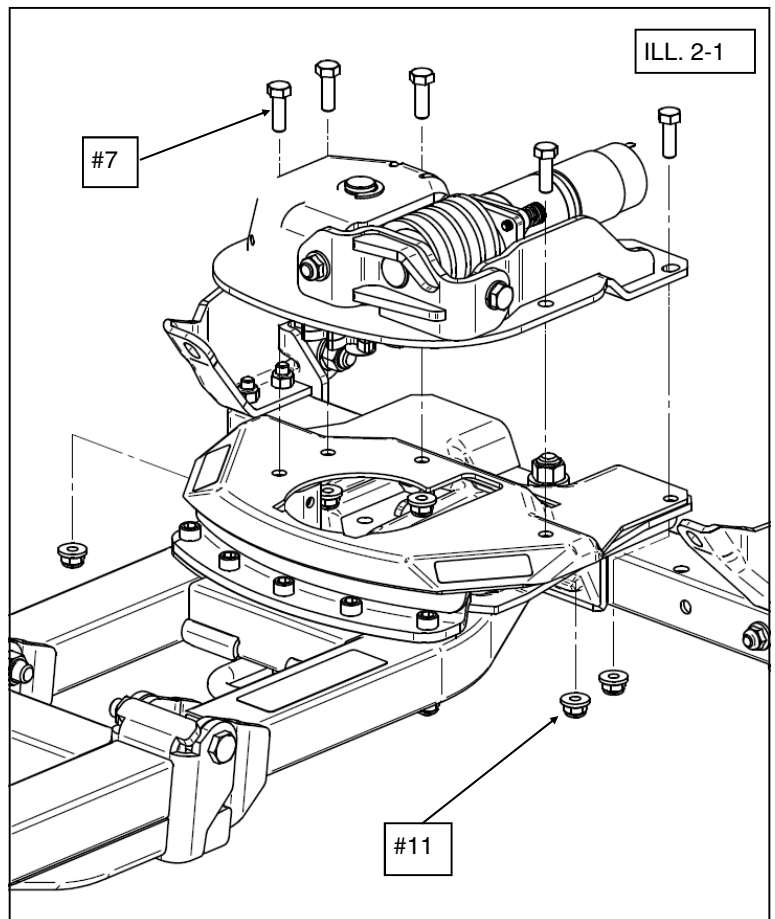
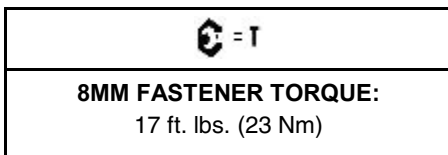

2. Note, for the hard-to-reach nuts, use a 13mm wrench to hold the nuts while tightening. (See illustration 2-3).

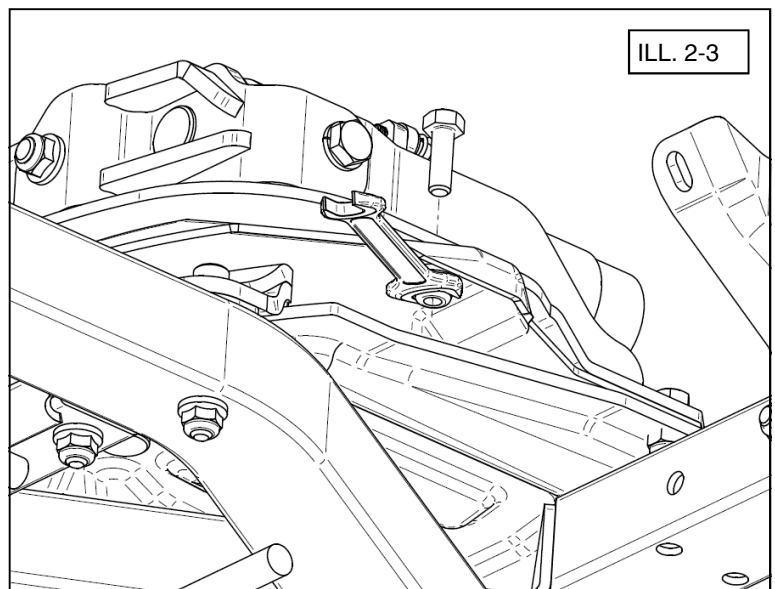

## POWER ANGLE INSTALLATION ONTO PUSH FRAME ASSEMBLY (continued):

3. Connect the wiring (item #21) to the motor. Plug the white wire and black wire to the motor connectors as shown. Use the holes found on the left side of the gear housing to safely route the wiring using the included cable ties. (See illustration 2-4).
4. Then connect the wire harness (item #23) to the vehicle battery or power terminal block. The fused ring terminal wire lead connects to 12 VDC positive connection. The black ring terminal wire connects to the vehicle ground connection or negative battery terminal. **Note, see the wiring diagram and switch installations on following pages.**
5. Install the new plastic cap (item #25) over the angling kit as shown. Be careful not to damage the wiring during installation. Begin by hooking the front of the cap to the front of the unit, then tilt the rear down until it clips. (See illustration 2-5).
6. Once cap is installed, secure using self-tapping screws (item #30) as shown. Tighten the screws until snug. (See illustration 2-6). **Note, older gen plow frames may not have pre-drilled holes for self-tapping screws. Use the plastic cap as pattern to mark hole location and drill using 1/8" drill bit (3.2mm).**

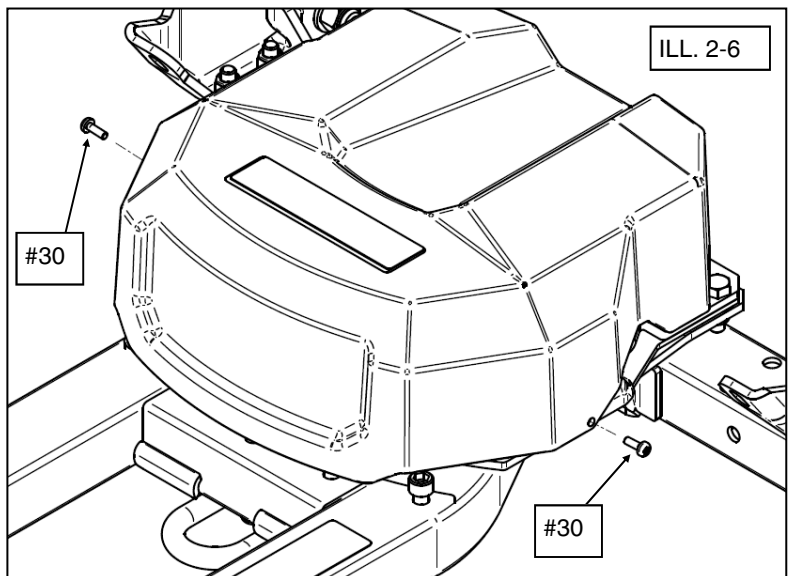
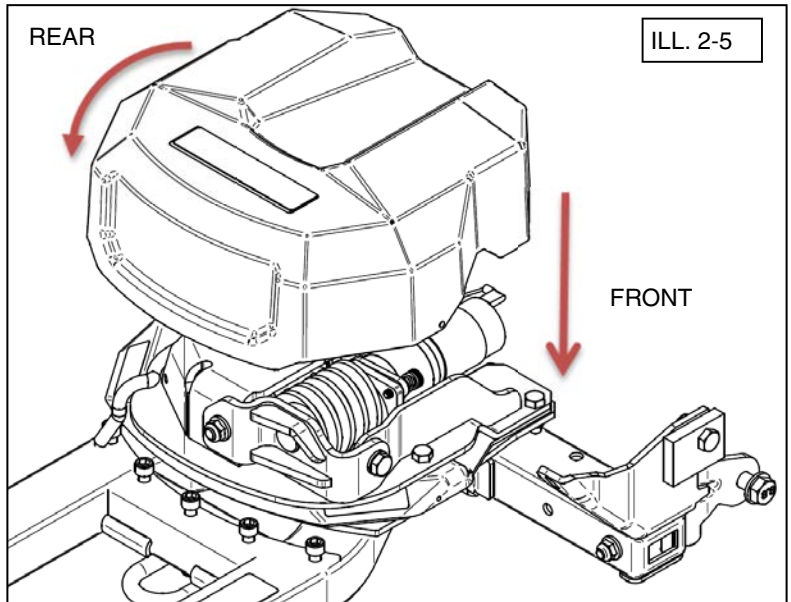
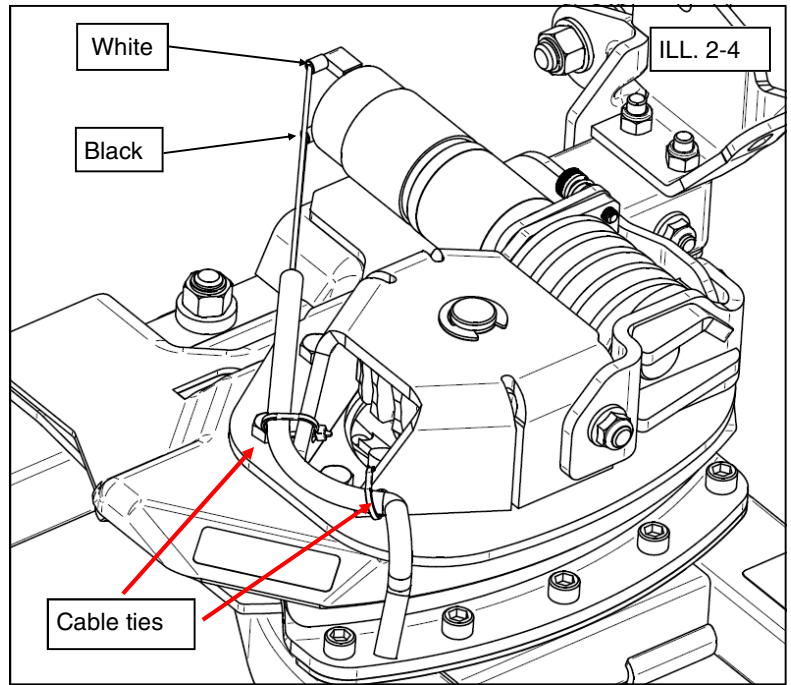



## SWITCH INSTALLATION ONTO ATV VEHICLE:

1. Install the bar clamps (item #16), straight section bracket (item #17) and switch bracket (item #18) onto the handlebar using screws (items #13 & #14) and nuts (item #8) as shown below. (See illustration 3-1).
2. Route the wiring and connected switch thru the plastic cap (item #19), then continue routing it along the handlebar using included cable ties. **Note, make sure to route wires where it will not make contact with hot engine surfaces or will be pinched by body components or make contact with moving parts.**
3. Verify the orientation of the angling kit switch by operating the motor using the switch. This will determine the orientation of the switch in the housing. Using the left arrow, the blade should be rotating counterclockwise (the left side of the plow rotating toward the vehicle). Be careful of your surroundings when operating the plow angling kit.
4. Install the switch inside the plastic cover (item #19) in the correct orientation.
5. Clip the plastic cover to the switch bracket (item #18). **Note, if the angling kit is not turning the correct way, the switch will need to be rotated 180 degrees in the housing. Using the left arrow, the blade should be rotating counterclockwise to the left (the left side of the blade rotating toward ATV).**

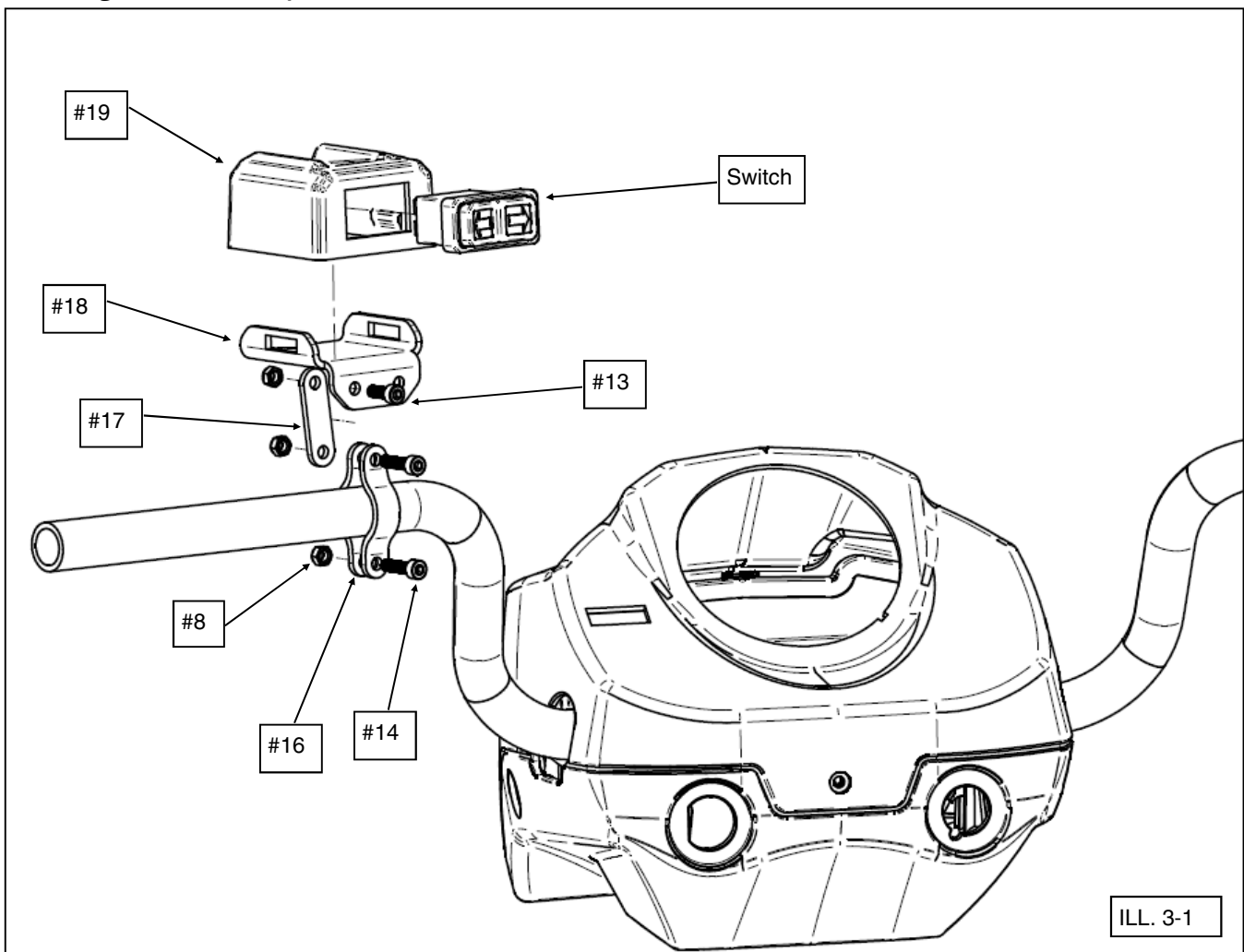

ILL. 3-1

## SWITCH INSTALLATION ONTO UTV VEHICLE:

1. To dash mount switch onto UTV, the switch bracket will need to be disassembled from factory ATV setup. Remove the switch from the switch bracket (item #18) and plastic switch cap (item #19) as shown below. For UTV installations, the ATV switch cover and bracket assemblies will not be needed. Save the wiring for next steps. (See illustration 4-1).
2. Prepare location for dash panel mount. Using the panel hole cut out pattern below, mark or scribe the rectangle pattern into the dash. Using plastic cutting tool such as Dremel or drill bit, remove the material for the cut out. (See illustration 4-2 for cut out pattern dimensions. **Note illustration 4-2 is not to scale, please confirm measurements with ruler.**)
3. Route the wiring and connected switch thru the dash cut out, then continue routing it along the body or frame using included cable ties. **Note, make sure to route wires where it will not make contact with hot engine surfaces or will be pinched by body components or make contact with moving parts.**
4. Verify the orientation of the angling kit switch by operating the motor using the switch. This will determine the orientation of the switch in the housing. Using the left arrow, the blade should be rotating counterclockwise (the left side of the plow rotating toward the vehicle). Be careful of your surroundings when operating the plow angling kit.
5. Clip the switch into the dash hole cut-out. (See example images below). **Note, if the angling kit is not turning the correct way, the switch will need to be rotated 180 degrees in the housing. Using the left arrow, the blade should be rotating counterclockwise to the left (the left side of the blade rotating toward UTV).**

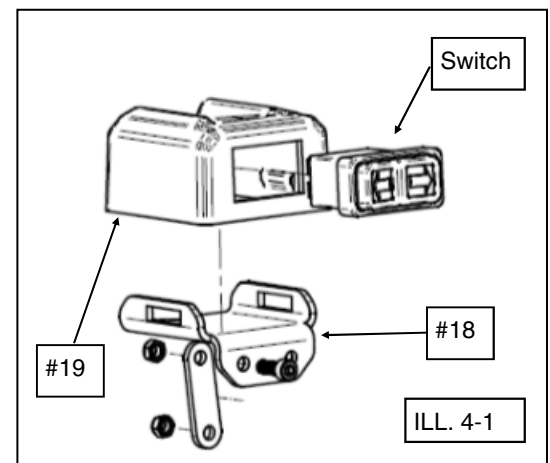
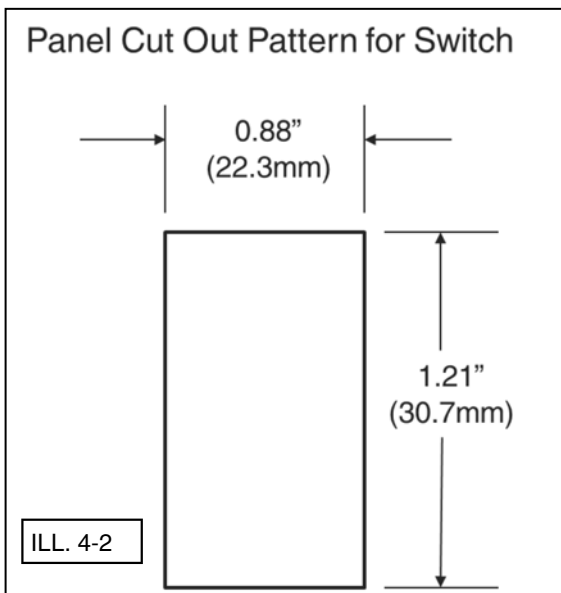

## Wiring Diagram:

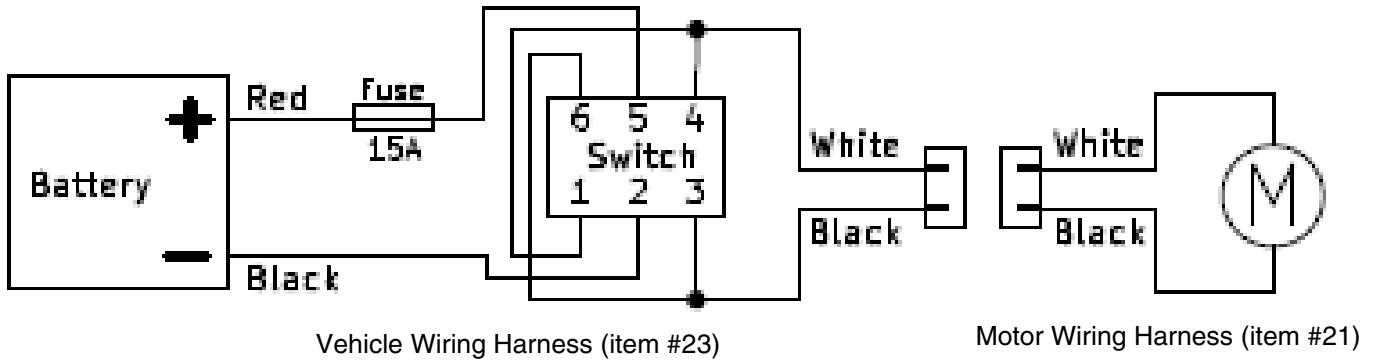

## WIRE HARNESS ROUTING ON VEHICLE:

1. The vehicle wire harness (item #23) can be routed to the front grill area and secured using provided cable ties (item #1) as shown. To allow for plow raising and lowering movements, make sure to leave enough slack wire length from connector to cable tie. (See illustration 5-1).
2. The vehicle wire harness (item #23) includes a cover cap for the connector. The cap can be attached to the vehicle using provided cable ties (item #1) or badge trim adhesive (not included). When the plow is not attached to vehicle, the wire harness can be plugged into the cover cap as shown. (See illustration 5-2).

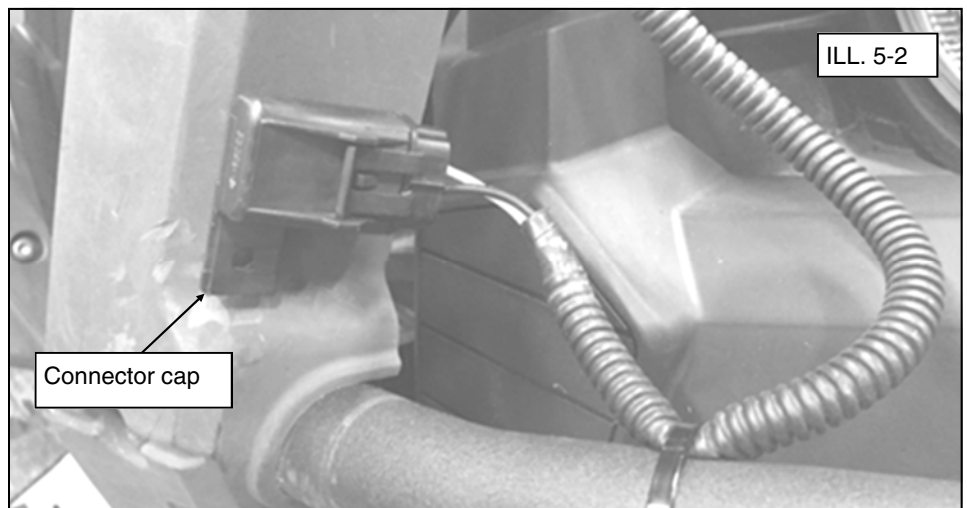
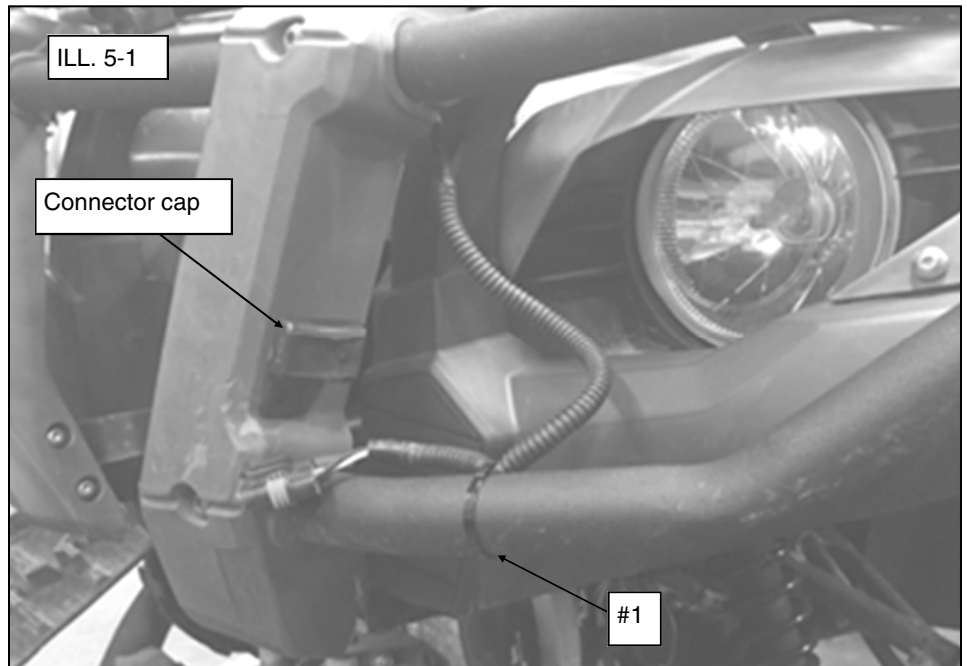



## **USAGE INSTRUCTIONS:**

1. Use the angling kit only when the plow is up, with no contact on the ground or against any obstacle.
2. Once the plow is not turning anymore (due to an obstacle or being locked in the furthest angle position on either side), release the switch.
3. Do not keep operating the angling kit when the plow is locked.
4. If there is ice build-up on gear system preventing power angle pivot operation, let plow system thaw in warm environment for 30 minutes.
5. Operate the power angle system per the duty cycle listed below.

## **DUTY CYCLE:**

- Run Time: 10 seconds free or 2 seconds locked
- Cool Time: 45 seconds
- Do not use over 65°F (18°F) or under -20°F (-28°C)

## **TROUBLESHOOTING:**

- If the plow is not turning:
  - ◇ Check the fuse (located near positive terminal connection) for the Power Angle wiring harness
  - ◇ Check for dust or debris (ice, gravel, etc.) in the gears (located under plastic cap)
  - ◇ Check for any damage to the gear sets or plow push frame (related to hard impacts)
  - ◇ Check the connectors on the motor for a loose connection
  - ◇ Check the wiring for any damage
  - ◇ Check the battery voltage (continuous use with the vehicle not running will drain the battery)

## **MAINTENANCE:**

- Lightly grease the worm gears annually
- To remove dust or debris build-up on gears, use water to loosen material, then blow dry with pressurized clean air

# SPARE KITS

Item	Description	Motor kit P/N 33-0111	Wiring kit P/N 33-0112	Gear kit P/N 33-0115	Hardware kit P/N 33-0117	Plastic Cap kit P/N 33-0120
1	Cable Tie, 141mm long		13x			
2	Carriage Bolt, Zinc Plated, M10-1.5 x 25mm				1x	
3	Circlip, Zinc Plated			1x		
4	Flat Socket Head Cap Screw, Zinc Plated, M4-0.7 x 10mm				4x	
5	Set Screw, Zinc Plated, M6-1.0 x 12mm			1x		
6	Hex Bolt, Zinc Plated, M10-1.5 x 25mm				1x	
7	Hex Bolt, Zinc Plated, M8-1.25 x 25mm				5x	
8	Hex Nylon Nut, Zinc Plated, M5-0.8		3x			
9	Lock Washer, Zinc Plated, M10				1x	
10	Nylon Flange Nut, Zinc Plated, M10-1.5				1x	
11	Nylon Flange Nut, Zinc Plated, M8-1.25				5x	
12	Shoulder Screw, Zinc Plated, Dia. 8mm x 14mm, M6-1.0				2x	
13	Socket Head Cap Screw, Zinc Plated, M5-0.8 x 14mm		1x			
14	Socket Head Cap Screw, Zinc Plated, M5-0.8 x 20mm		2x			
15	Gear Assembly			1x		
16	Handlebar Clamp		2x			
17	Straight Section Bracket		1x			
18	Switch Bracket		1x			
19	Plastic Switch Cap		1x			
21	Wiring Assembly		1x			
23	ATV Wiring Harness		1x			
24	Worm			1x		
25	Plastic Cap					1x
26	Decal					1x
27	Spring				2x	
28	Motor Mounting Plate				1x	
29	Electric Motor	1x				
30	Self-Tapping Screw, Zinc Plated, M4-0.7 x 12mm LG					2x

## SPARE KITS:

See the table on page 12 for a full description.

Motor kit (PN 33-0111)

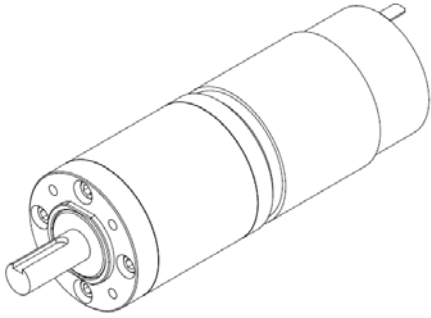

Wiring kit  
(PN 33-0112)

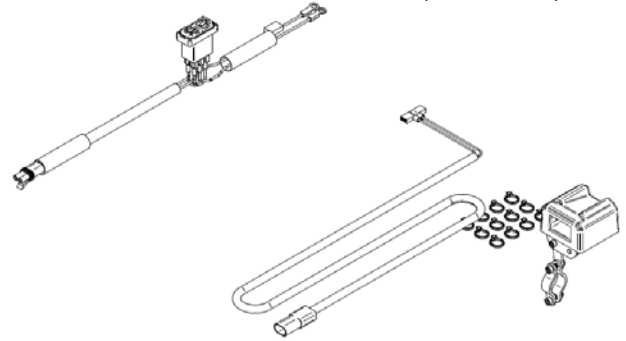

Gear kit (PN 33-0115)

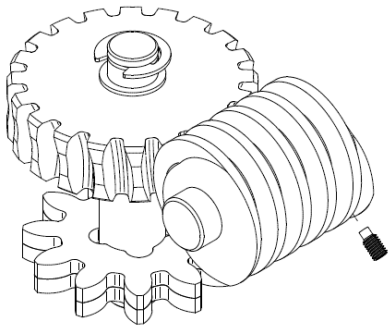

Hardware kit  
(PN 33-0117)

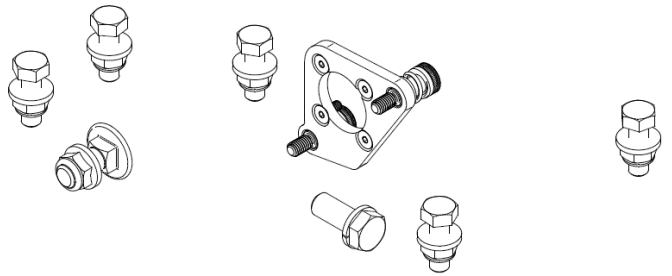

Plastic cap kit  
(PN 33-0120)

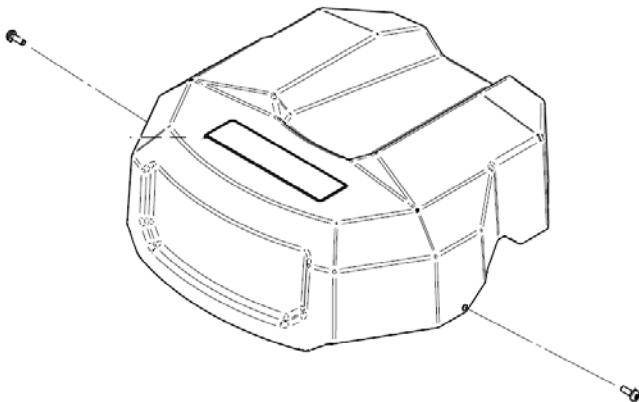



## Two Year Limited Warranty

For the period of two (2) years from the purchase date, Kolpin will replace for the original purchaser, free of charge, any part or parts found upon examination by Kolpin to be defective in material, workmanship, or both.

All transportation costs incurred submitting product to Kolpin for warranty consideration must be borne by the purchaser. If Kolpin determines that the product must be returned to the factory for credit, please call 1-877-956-5746 for a Return Merchandise Authorization (RMA) number and shipping instructions.

This warranty does not apply to parts that have been damaged by accident, alteration, abuse, improper maintenance, normal wear, or other causes beyond the manufacturer's control. In order to protect you and your ATV, certain parts of the plow system and/or hardware are designed to fail when the equipment is over-stressed. Parts that are lost due to loosening and improper maintenance are not covered under warranty. This warranty does not cover removal or reinstallation labor fees of the plow system and related components.

Peripheral products such as engines, electric motors, and actuators may carry an original manufacturer's warranty. Most hardware is general in nature and is easily obtained locally. Be sure to replace with minimum metric class 8.8 specification.

**Kolpin Outdoors, Inc.**

**Telephone: (763)-478-5800**

**Toll Free: (877)-956-5746**

**Fax Number: (800)-245-7569**

**[www.kolpin.com](http://www.kolpin.com)**

**Email: [customerservice@kolpin.com](mailto:customerservice@kolpin.com)**

# **KOLPIN<sup>®</sup>** **OUTDOORS**

**2500 lb / 3500 lb / 4500 lb**

## **ATV / UTV WINCH KIT**

**P/Ns: 25-9250, 25-9255, 25-9350, 25-9355, 25-9450, 25-9455**

**OWNER'S / OPERATING INSTRUCTIONS / SPARE PARTS**

Application

WINCH MOUNT NO. 25-XXXX, OEM VEHICLE WINCH MOUNTS

Before you begin, please read these instructions and check to be sure all parts and tools are accounted for. The following instructions contain details required to operate, install and service the contents of this kit. Save these instructions. Important safety instructions are included in this manual.



# **TABLE OF CONTENTS**

## **Introduction**

Introduction .....	3
Guidebook Conventions .....	3

## **Controls and Features** .....

4

Winch .....	4
-------------	---

## **Assembly** .....

5

Mounting .....	5
Mounting the winch .....	5
Mounting the handlebar switch .....	6
Mounting the contactor/solenoid .....	6
Mounting the remote switch (optional) .....	7

Wiring the winch .....	7
Winch Wiring diagram .....	8
Corded Remote and Rocker Switch Wiring Diagram .....	9

## **ATV/UTV Winch User Guide** .....

10

Winch Safety Precautions .....	10-11
Winch Operation .....	12-14
Wire Cable Care .....	14
Shock loading .....	15

## **Winch Maintenance and Service Safety** .....

16

Lubrication .....	16
Cable Assembly Replacement .....	16

## **Specifications** .....

17

Performance Specifications .....	17
Parts Kit Diagrams and replacement part numbers .....	18-23

## **Troubleshooting** .....

24

## **Warranty** .....

25

## INTRODUCTION

Congratulations on your purchase of a Kolpin winch! The Kolpin winch works great for vehicle recovery and plow lift applications. With proper use and maintenance, this winch will bring many years of satisfying service.

Every effort has been made to ensure the accuracy and completeness of the information in this manual. We reserve the right to change, alter and/or improve the product and this document at any time without prior notice.

Record the part numbers, date of purchase and place of purchase for future reference. Please have this information available when ordering parts and when making technical or warranty inquiries.

<b>Kolpin Outdoors Support</b>
1-877-956-5746
<b>Part Number</b>
<b>Date of Purchase</b>
<b>Purchase Location</b>

## GUIDEBOOK CONVENTIONS

This manual uses the following symbols to help differentiate between different kinds of information. The safety symbol is used with a signal word to alert you to potential hazards in operating and owning power equipment. Follow all safety messages to avoid or reduce the risk of serious injury or death. Each message has a specific purpose. **PLEASE WORK SAFELY!**

 <b>WARNING</b>
<b>WARNING</b> indicates a potentially hazardous situation that, if not avoided, could result in death or serious injury.

<b>NOTICE</b>
<b>NOTICE</b> indicates a potentially hazardous situation which, if not avoided, may result in property damage.

 <b>CAUTION</b>
<b>CAUTION</b> indicates a potentially hazardous situation that, if not avoided, may result in minor or moderate injury.

<b>NOTE</b>
If you have questions regarding your winch, we can help. Please call our help line at <b>1-877-956-5746</b> .

# CONTROLS AND FEATURES

Read this owner's manual before operating your winch. Familiarize yourself with the location and function of the controls and features. Save this manual for future reference. Some features may not exist on all models, but can be ordered as options, please contact technical services at **1-877-956-5746**.

## WINCH

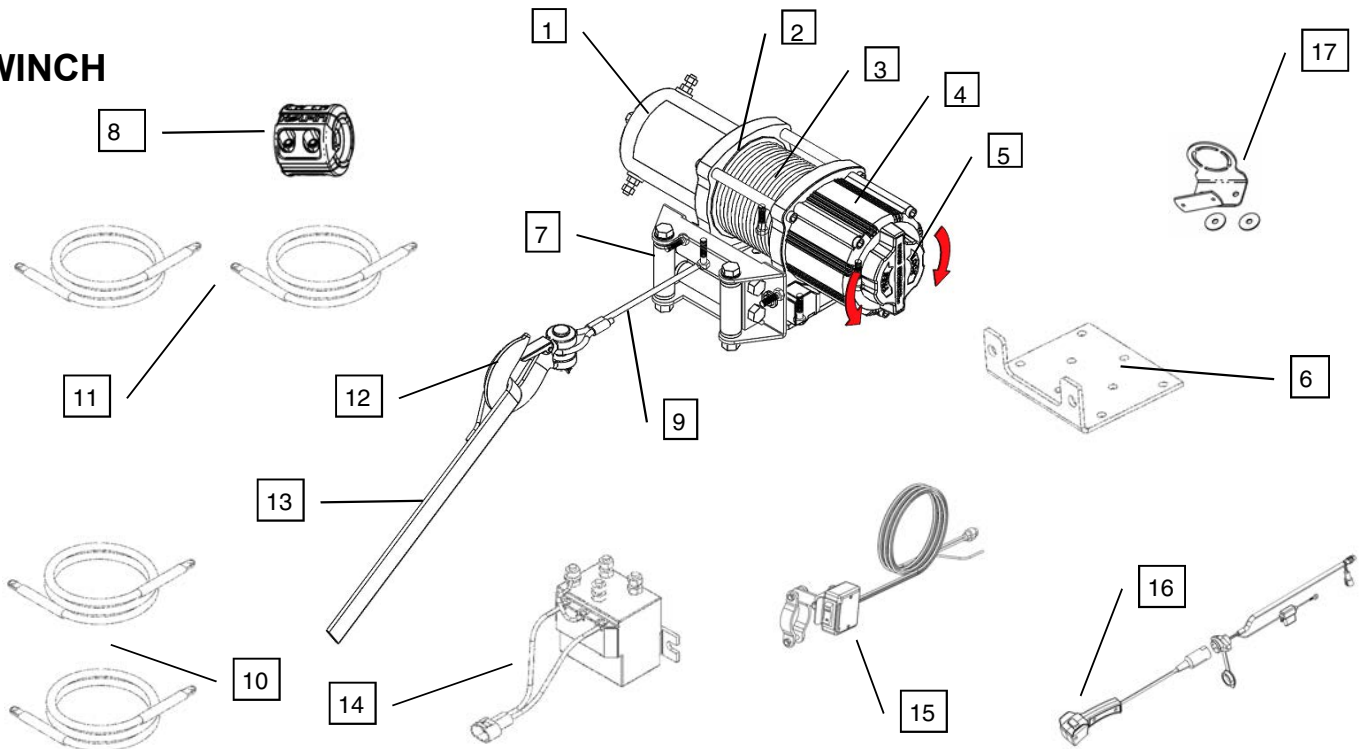

- (1) **Motor:** 12V DC motor provides power to the planetary gear mechanism.
- (2) **Braking System:** Braking action is automatically applied to the winch drum when the winch motor is stopped and there is a load on the winch cable.
- (3) **Winch Drum:** The winch drum is the cylinder on which the wire rope is stored. It can feed or wind the rope depending on the remote winch switch signal.
- (4) **Planetary Gear System:** The reduction gears convert the winch motor power into extreme pulling forces. This system allows high torque while maintaining compact size and light weight.
- (5) **Free Spooling Clutch:** The clutch allows the operator to manually disengage “Out” the spooling drum from the gear train, free spool. Engaging the clutch “In” locks the winch into the gear system.
- (6) **Mount Assembly:** Flatbed mounting channel.
- (7) **Roller Fairlead:** When using the winch at an angle, the roller fairlead acts to guide the wire rope onto the drum and minimizes damage to the wire rope from abrasion on the winch mount or bumper.
- (8) **Rubber Winch Stop:** Increases life of cables, ropes and fairleads. Quiets hook rattling noise.
- (9) **Rope:** Galvanized steel aircraft cable or synthetic rope designed specifically for winch load capacities.
- (10) **Winch Connection Cables:** Used to connect the contactor to the winch motor.
- (11) **Battery Connection Cables:** Used to connect the battery to the contactor.
- (12) **Clevis Hook:** Provides a means for connecting the looped ends of cables to an anchor.
- (13) **Strap:** Used to assist cable feed.
- (14) **Contactor/solenoid:** Power from the vehicle battery flows through the weather sealed contactor/solenoid switch before being directed to the winch motor.
- (15) **Rocker Switch:** Rocker switch with handlebar mount for powering the rope in or out of your winch drum.
- (16) **Corded Remote Switch:** Corded remote switch allows the operator to stand clear during the winching process.
- (17) **Dash Mount Bracket:** Bracket allows the handlebar rocker switch to be installed onto a dash surface.



# ASSEMBLY

The winch kit comes mostly assembled from the factory. Some pre-assembly of the kit is required for installation into vehicles.

## BEFORE YOU BEGIN:

- Your Kolpin accessory is designed for a universe fit for most vehicles.
- Please read and understand all instructions.
- Verify all parts and tools are accounted for.
- To ensure a satisfactory installation, follow all steps correctly and in the sequence described.
- To facilitate installation, make sure that your vehicle is clean and free of debris.
- All directions referring to right and left are when the rider is sitting on the machine.

## TOOLS REQUIRED:

- Basic metric wrench set
- Basic metric socket set
- Pliers
- Philips screwdriver

## MOUNTING THE WINCH

- If using a winch mounting kit, refer to the kit's manual for specific installation instructions. *See Kolpin.com for a full assortment of custom winch mounts for ATV/UTVs.*
- Mount the winch to the mount plate (not included) as shown below. Rotate the lock knob to the free spool position and feed the winch cable through the rollers of the roller fairlead.
- Mount the roller fairlead plate and attach the hook clevis and nylon pull strap. Rotate the lock knob back to the lock position.

**! WARNING**  
ALWAYS use supplied hook strap.

## NOTICE

ALWAYS ensure that the 3 major sections (motor, drum, gear housing) are properly aligned if utilizing a mounting plate. Proper alignment of the winch will allow for even distribution of the full rated load.

Roller fairlead or aluminum hawse (orientate warning label to face upwards or outwards so it is visible when viewing from front of vehicle)

Clevis hook

Nylon strap

**Note: If any hardware is missing, do not return to the store. Call us to help, Toll Free 1-877-956-5746.**

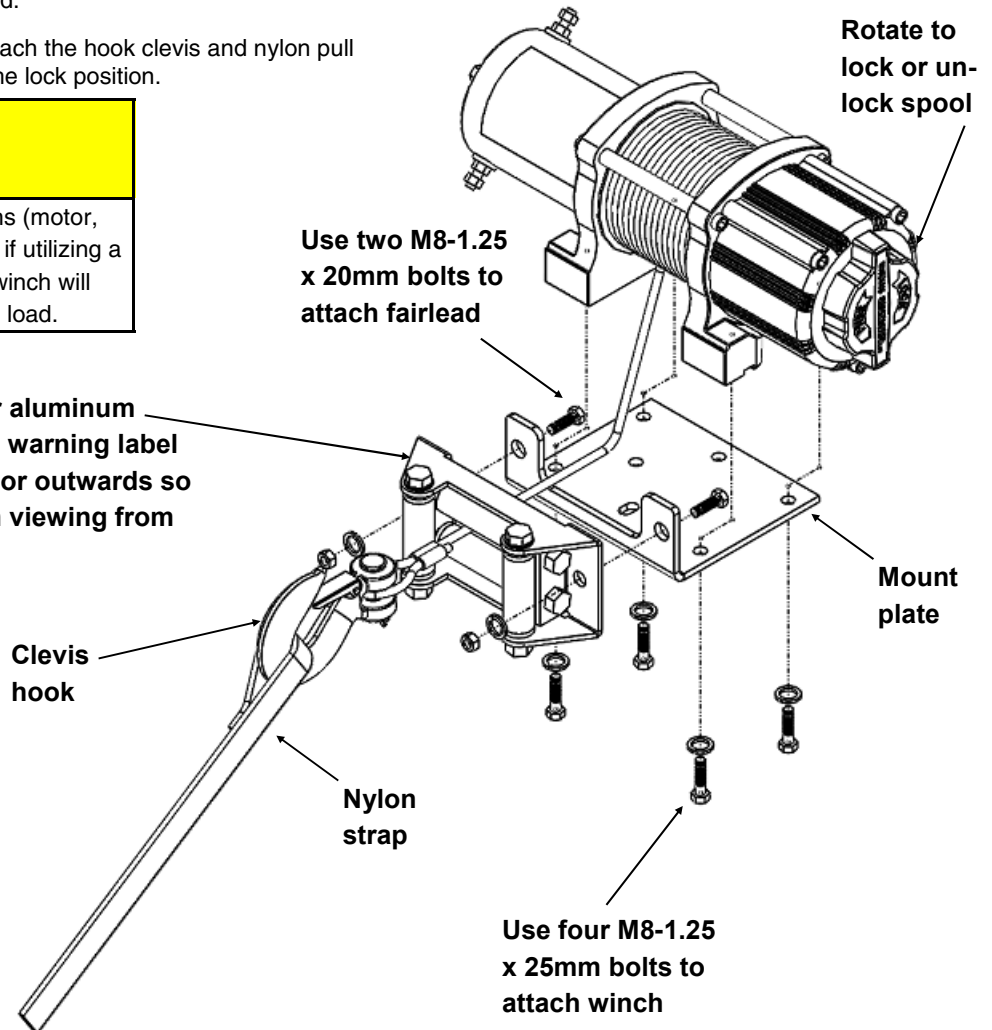

## MOUNTING THE HANDLEBAR SWITCH

- Install the rocker switch to the handlebar using the hardware included in this kit as shown below.
- It is recommended that the switch be installed on the left handlebar. Exact position may vary depending on vehicle.
- Use a piece of electrical tape (not provided) around the handlebar to help prevent rotation of the switch bracket mount.
- Tighten the rocker switch in place. DO NOT overtighten or tighten/clamp over any hose, wiring or cables.
- Once the rocker switch is mounted, the wires can be routed to the contactor/solenoid location.
- Make sure the handlebars have full range of motion, vehicle switches/brakes/throttle can move freely, and then secure the rocker switch's cable with the supplied cable ties.
- Using the provided wire splice, splice the end of the red 20ga wire to a key controlled, fused, accessory circuit (power point) of the ATV/UTV. The wire should only have power when the key is in the "ON" position.

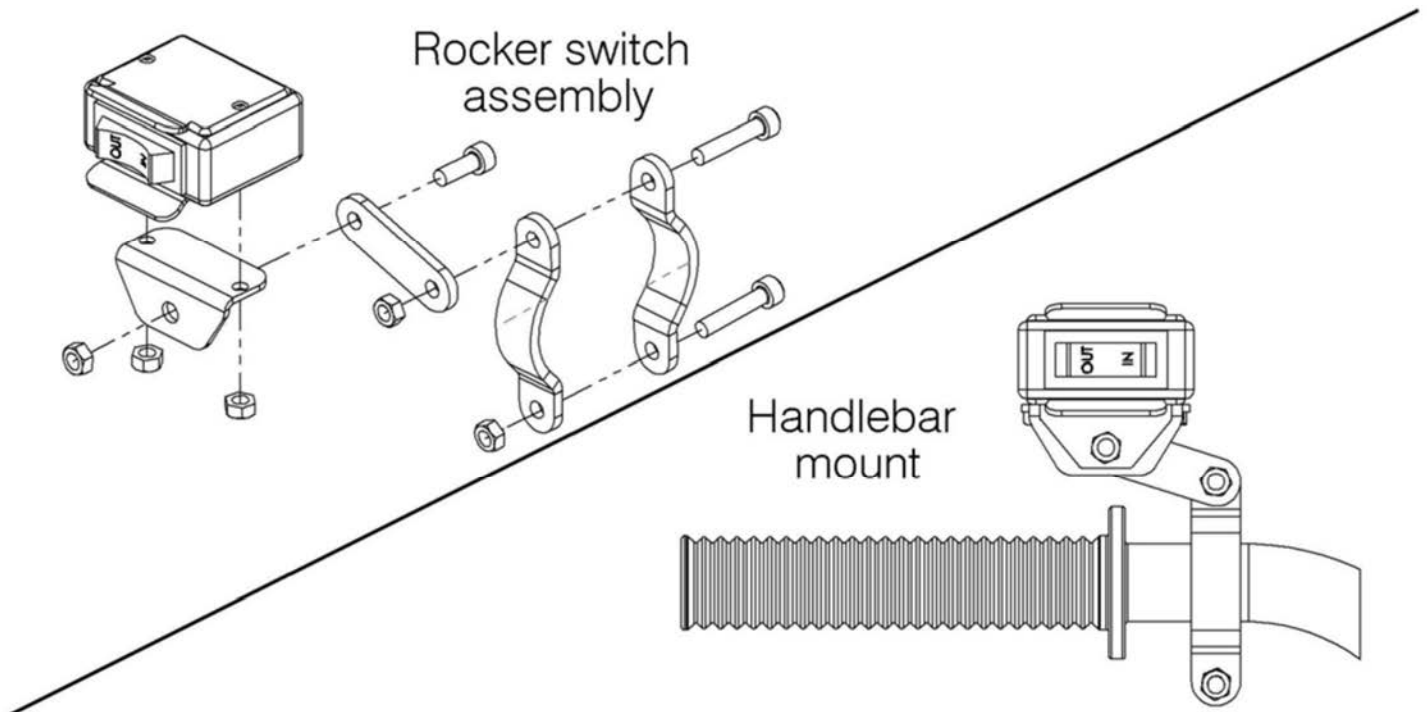

## MOUNTING THE CONTACTOR/SOLENOID

- The contactor/solenoid is a primary safety feature in the winch system. It disconnects the winch from its power source when the vehicle is not in use. The contactor/solenoid must be correctly installed to work properly.
- Find a location for the contactor/solenoid. It is recommended that the contactor/solenoid be mounted close to the battery in a clean, dry location. The exact location of the contactor/solenoid will vary depending on the vehicle. Make sure the location chosen allows for sufficient clearance from all metal components such as frame tubes. DO NOT place tools or other items in a position that might come in contact with the contactor/solenoid posts.
- Drill mounting holes if required. Secure the contactor/solenoid using the provided hardware.
- Once a location is found for the contactor/solenoid, DO NOT install the unit until all wiring is completed (see wiring section). Pre-fit all wiring to confirm its long enough to reach the battery and the winch contact locations.

**! WARNING**

**NEVER** short battery terminals with metal objects. Be aware terminals in contact with metal will cause a direct short, possibly causing contactor/ solenoid

## MOUNTING THE REMOTE SWITCH

### (optional on some models)

- Determine the mounting location for the remote socket. Exact position may vary depending on vehicle. Drill three holes and install to vehicle dash panel or body panel.
- Route the wire harness to where the contactor/solenoid will be mounted. Secure the socket's cable with the supplied cable ties.
- Using the provided wire splice, splice the end of the red 20ga wire to a key controlled, accessory circuit (power-point) of the ATV/UTV or use the provided 20ga wire eyelet terminal connector to connect to a vehicle terminal strip post. The wire should only have power when the key is in the "ON" position.
- **NOTE: If installing both switches (handlebar rocker and corded remote), both 20ga red wires must be connected together with the provided plug connectors or spliced to a key-controlled accessory circuit of the ATV/UTV as described in the above step.**

## NOTICE

**ALWAYS** make sure to splice into keyed accessory wire that has power when key is turned on. You may need to use a test light to locate a suitable wire.

## WIRING THE WINCH

- Install the wiring using the diagram on the next page.
- Slip terminal boots on yellow and blue cable ends. Connect the yellow and blue cables to the color-matched motor terminals on the winch. Tighten the terminal nuts on the motor. **DO NOT** overtighten. Seat boots over terminal. Route the other ends to the contactor/solenoid location.
- Connect the yellow and blue cables to the contactor/solenoid (yellow to yellow and blue to blue). **DO NOT** tighten nuts or seat boots at this time.
- Slip terminal boots on the ring terminal ends of the black and red cables. Connect the black and red cables to the contactor/solenoid (red to red and black to black). **DO NOT** tighten nuts or seat boots at this time. Route red and black cables to battery. **DO NOT** connect cables to battery at this time.
- **Mount the contactor to the location planned in the previous steps with provided hardware. Tighten the contactor/solenoid mounting fasteners. DO NOT overtighten.**
- Adjust cables to facilitate orderly and straight routing of the cables from the contactor/solenoid. Avoid kinks or sharp bends in the cables. Avoid crossing cables over each other for at least the first 6" of cable starting from the contactor/solenoid post. Tighten the contactor/solenoid terminal nuts. **DO NOT** over tighten. Seat terminal boots over ring terminals and posts.
- Connect the rocker switch to the contactor/solenoid using the provided plug. Splice the end of the red wire on the rocker switch, to a vehicle accessory circuit controlled by ignition controlled power source (keyed). The wire should only have power when the key is in the "ON" position.
- Carefully inspect battery and winch electrical cable routing to ensure it is neat and tidy. Secure electrical cables and wiring harnesses with provided cable ties. Cable ties should be snug, but not cutting into wire insulation. Use electrical tape, pieces of rubber hose or electrical conduit to protect electrical cables and wire harnesses where needed to avoid electrical cable insulation wear or abrasion.
- Connect the red lead to the positive (+) terminal of the vehicle's 12 volt battery first. Connect the black lead to the negative (-) terminal of the vehicle's 12 volt battery second. Install protective boots as appropriate to protect connection. Tighten battery terminal fasteners as directed in the vehicle service manual to the proper torque specification.
- Check for proper drum rotation. Pull and turn the clutch knob to the "free spool" position. Pull out some cable from the drum, and then turn the clutch knob to the "locked spool" position to engage the gears. Press the cable out button on the rocker switch. If the drum is turning and releasing more cable, your connections are accurate. If the drum is turning and collecting more cable, then reverse the leads on the motor. Repeat and check rotation.
- With some applications, the motor terminal posts may need to be rotated to avoid interference with other components.

## CAUTION

**NEVER** route electrical cables across any sharp edges, through and /or near moving parts, or near parts that may become hot.

## CAUTION

**ALWAYS** leave some slack for electrical cable movement. Battery cables should **NOT** be drawn taut.

# WINCH WIRING DIAGRAM

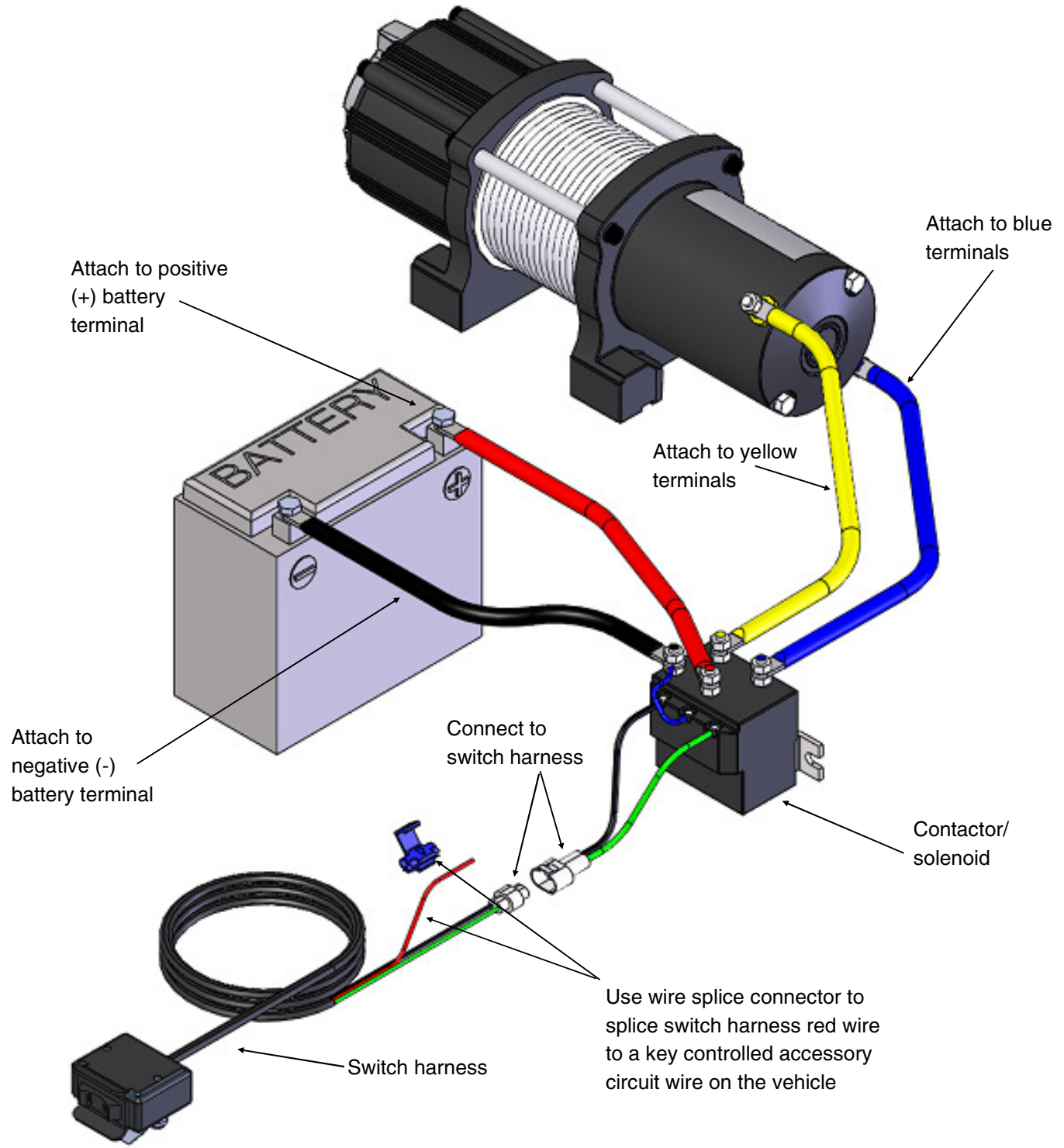



# CORDED REMOTE AND ROCKER SWITCH WIRING DIAGRAM

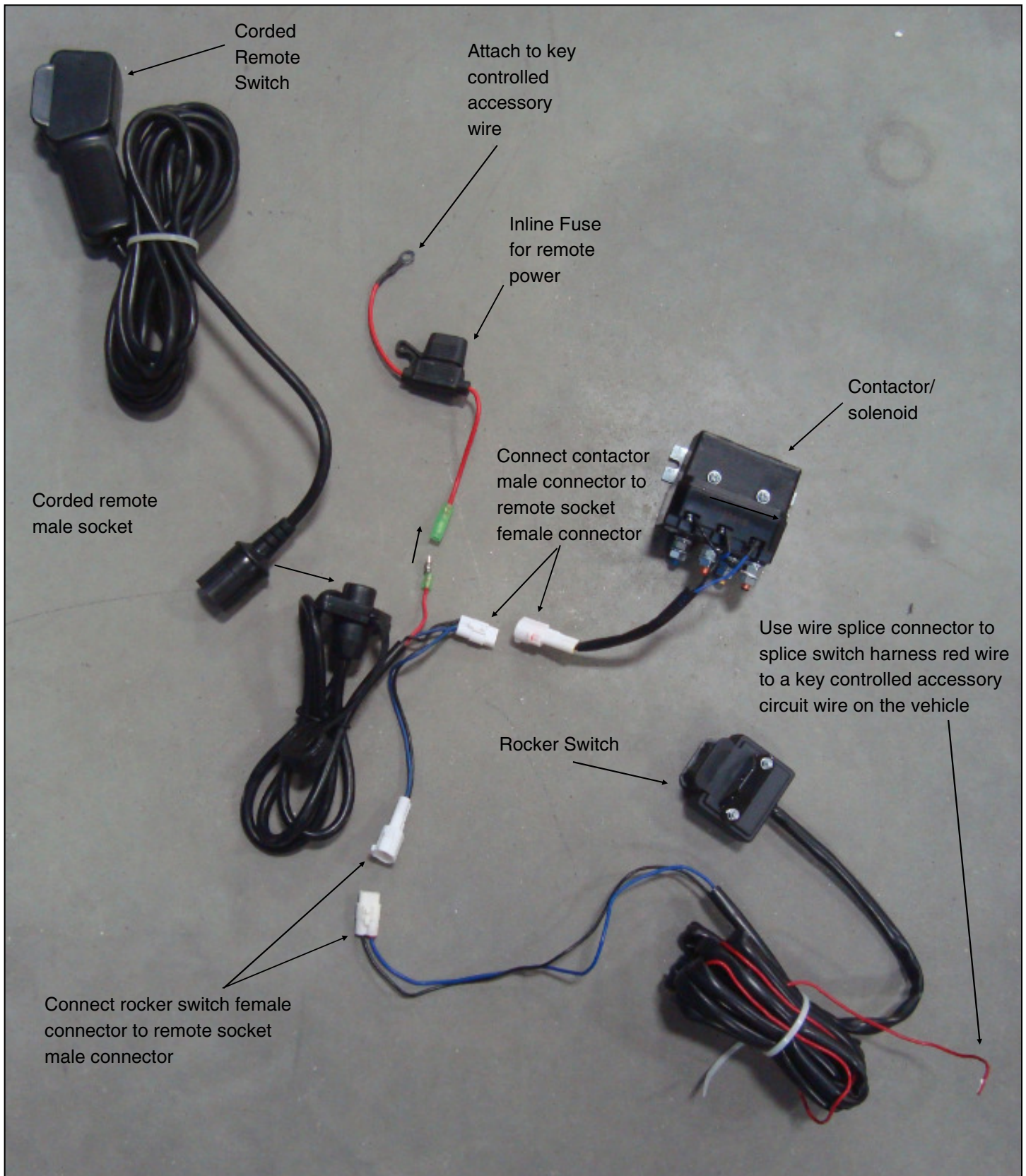

# ATV/UTV WINCH USER GUIDE

Before you begin using your winch, read and understand the guide. Please retain this guide for future reference.

These safety warnings and instructions apply if you choose to add an accessory winch to your vehicle.



Your winch may have a cable made of either wire rope or specially designed synthetic rope. The term “winch cable” will be used for either unless noted otherwise.

## WINCH SAFETY PRECAUTIONS

1. Read all sections of this manual.
2. Never use alcohol or drugs before or while operating the winch.
3. Never allow children under 16 years of age to operate the winch.
4. Always wear eye protection and heavy gloves when operating the winch.
5. Always keep body, hair, clothing and jewelry clear of the winch cable, fairlead and hook when operating winch.
6. Never attempt to “jerk” a load attached to the winch with a moving vehicle. See the **Shock Loading** section on page 15.
7. Always keep the area around the vehicle, winch, winch cable and load clear of people (especially children) and distractions while operating the winch.
8. Always turn the vehicle ignition power OFF when it and the winch are not being used.
9. Always be sure that at least five full turns of winch cable are wrapped around the winch drum at all times. The friction provided by this wrapped cable allows the drum to pull on the winch cable and move the load.
10. Always apply your vehicle’s park brake and/or park mechanism to hold the vehicle in place during winching. Use wheel chocks if needed.
11. Always align the vehicle and winch with the load directly in front of the vehicle as much as possible. Avoid winching with the winch cable at an angle to the winching vehicle’s center line whenever possible.
12. If winching at an angle is unavoidable, follow these precautions:
  - A. Look at the winch drum occasionally. Never let the winch cable “stack” or accumulate at one end of the winch drum. Too much winch cable at one end of the winch drum can damage the winch and the winch cable.
  - B. If stacking occurs, stop winching. Follow step 15 on page 4 to feed and rewind the cable evenly before continuing the winch operation.
13. Never winch up or down at sharp angles. This can destabilize the winching vehicle and possibly cause it to move without warning.
14. Never attempt to winch loads that weigh more than the winch’s rated capacity.
15. The winch motor may become hot during winch use. If you winch for more than 45 seconds, or if the winch stalls during operation, stop winching and permit the winch to cool down for 10 minutes before using it again.

## WINCH SAFETY PRECAUTIONS (continued)

16. Never touch, push, pull or straddle the winch cable while winching a load.
17. Never let the winch cable run through your hands, even if wearing heavy gloves.
18. Never release the clutch on the winch when the winch cable is under load.
19. Never use the winch for lifting or transporting people.
20. Never use the winch to hoist or suspend a vertical load.
21. Never immerse or submerge your winch in water. Take your winch to your dealer for service if this occurs.
22. Always inspect your winch and winch cable before each use.
23. Never winch the hook fully into the winch. This can cause damage to winch components.
24. Unplug the remote control from the vehicle when the winch is not in use to prevent inadvertent activation and use by unauthorized persons.
25. Never grease or oil the winch cable. This will cause the winch cable to collect debris that will shorten the life of the cable.

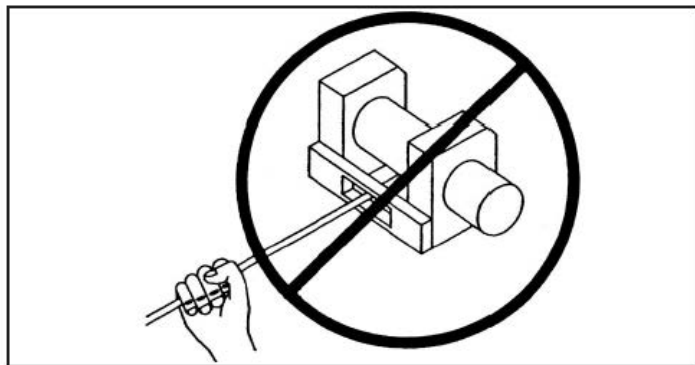

## WINCH OPERATION

Read the *Winch Safety Precautions* in the preceding pages before using your winch.

**TIP:** Consider practicing the operation and use of your winch before you actually need to use it in the field.

 **WARNING**

**ALWAYS** follow all winch instructions and warnings in this manual. Improper winch use can result in SEVERE INJURY or DEATH.

Each winching situation is unique:

- Take your time to think through the winching you are about to do.
  - Proceed slowly and deliberately.
  - Never hurry or rush during winching.
  - Always pay attention to your surroundings.
  - You may need to change your winching strategy if it is not working.
  - Always remember that your winch is very powerful.
  - There are simply some situations that you and your winch will not be able to deal with. Do not be afraid to ask others to help when this happens.
1. Always inspect the vehicle, winch, winch cable and winch controls for any signs of damage or parts in need of repair or replacement before each use. **Pay particular attention to the first three feet (one meter) of the winch cable if the winch is being used (or has been used) for lifting an accessory plow assembly.** Promptly replace any worn or damaged cable.
  2. Never operate a winch or a vehicle in need of repair or service.
  3. Always apply your vehicle's parking brake and/or park mechanism to hold the vehicle in place during winching. Use wheel chocks if needed.
  4. Always use the hook strap when handling the hook.

 **WARNING**

**NEVER** put your fingers into the hook. This could lead to SEVERE INJURY.

- A. Attach the hook itself onto the load or use a tow strap or chain to secure the load to the winch cable.

**TIP:** A "tow strap" is NOT intended to stretch. A "recovery strap" is designed to stretch.

 **WARNING**

**NEVER** use a recovery strap when winching due to the excessive energy that can be released if the winch cable breaks. This can result in SEVERE INJURY or DEATH. See the Shock Loading section on page 15.

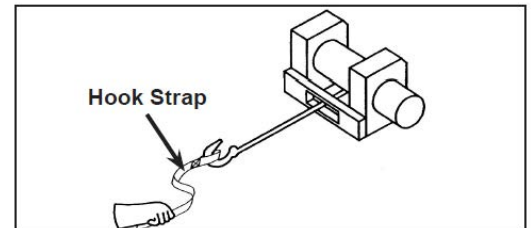



## WINCH OPERATION (continued)

- B. Never hook the winch cable back onto itself. This will damage the winch cable and may result in winch cable failure.

 **WARNING**

**ALWAYS** replace the winch cable at the first sign of damage to prevent SEVERE INJURY or DEATH in the event of a failure. For your safety, always replace KOLPIN winch parts (including the cable) with KOLPIN replacement parts available at your authorized KOLPIN dealer or the KOLPIN website.

- C. If possible, keep the winch cable aligned with the center line of the winching vehicle. This will help the spooling of the winch cable and reduce the load on the fairlead.
- D. If freeing a stuck vehicle by attaching to a tree, use an item such as a tow strap to avoid damaging the tree during winch operation. Sharp cables and chains can damage and even kill trees. Please remember to Tread Lightly® (treadlightly.org).

- E. Before operating the winch, be sure that the safety latch on the winch cable hook is fully seated when the load is attached.
- F. Never operate your winch with a damaged hook or latch. Always replace damaged parts before using the winch.

5. Never remove the hook strap from the hook.

6. Release the winch clutch and pull out the winch cable.

7. Pulling out as much cable as possible maximizes the winch's pulling capacity.

Always be sure that at least five full turns of winch cable are wrapped around the winch drum at all times. The friction provided by this wrapped cable allows the drum to pull on the winch cable and move the load.

8. Read and adhere to the following information for winch damping to ensure safe winch use.

- A. In order to absorb energy that could be released by a winch cable failure, always place a "damper" on the winch cable. A damper can be a heavy jacket, tarp, or other soft, dense object. A damper can absorb much of the energy released if a winch cable breaks when winching. Even a tree limb can help as a damper if no other items are available to you.
- B. Lay the damper on top of the mid-point of the winch cable length that is spooled out.
- C. On a long pull, it may be necessary to stop winching so that the damper can be repositioned to the new mid-point of the winch cable. Always release the tension on the winch cable before repositioning the damper.
- D. Avoid being directly in line with the winch cable whenever possible. Also, never permit others to stand near or in line with the winch cable during winch operation.

9. Never hook the winch cable back onto itself. This will damage the winch cable and may result in winch cable failure.

10. Never use straps, chains or other rigging items that are damaged or worn.

11. The **ONLY** time a winch-equipped vehicle should be moving when using the winch is when the vehicle itself is stuck. The winch equipped vehicle should **NEVER** be in motion to "shock" load the winch cable in an attempt to move a second stuck vehicle. See the **Shock Loading** section on page 14. For your safety, always follow these guidelines when winching a vehicle free:

- A. Release the winch clutch and spool out the necessary length of winch cable.
- B. Align the winch cable as close as possible to the winching vehicle's center line.
- C. Attach the winch cable hook to the anchor point or the stuck vehicle's frame following instructions in this manual.
- D. Re-engage the clutch on the winch.
- E. Slowly winch in the slack in the winch cable.
- F. Select the proper vehicle gear to propel the stuck vehicle in the direction of winching.
- G. Shift to the lowest gear available on the stuck vehicle.
- H. Slowly and carefully apply vehicle throttle and winch together to free the vehicle.
- I. Stop winching as soon as the stuck vehicle is able to propel itself without the help of the winch.
- J. Detach the winch cable hook.
- K. Rewind the winch cable evenly back onto the winch drum following the instructions in this manual.

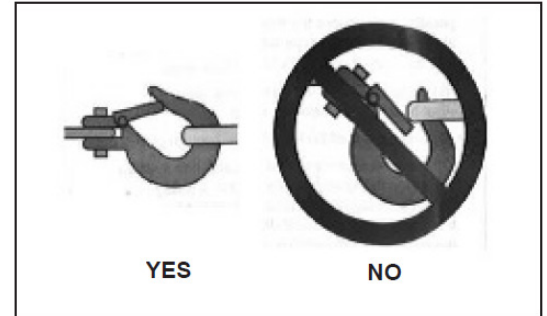

## WINCH OPERATION (continued)

12. Never attempt to winch another stuck vehicle by attaching the winch cable to a suspension component, brush guard, bumper or cargo rack. Vehicle damage may result. Instead, attach the winch to a strong portion of the vehicle frame or hitch.
13. Extensive winching will run down the battery on the winching vehicle. Let the winching vehicle's engine run while operating the winch to prevent the battery from running low if winching for long periods.
14. The winch motor may become hot during winch use. If you winch for more than 45 seconds, or if the winch stalls during operation, stop winching and permit the winch to cool down for 10 minutes before using it again.
15. After winching is complete, especially if winching at an angle, it may be necessary to re-distribute the winch cable across the winch drum. You will need an assistant to perform this task.
  - A. Release the clutch on the winch.
  - B. Feed out the winch cable that is unevenly bunched up in one area.
  - C. Re-engage the winch clutch.
  - D. Have an assistant pull the winch cable tightly with about 100 lbs. (45 kg) of tension using the hook strap.
  - E. Slowly winch the cable in while your assistant moves the end of the winch cable back and forth horizontally to evenly distribute the winch cable on the drum.
  - F. Doing this reduces the chances of the winch cable "wedging" itself between lower layers of winch cable.

## WINCH CABLE CARE

For your safety, always replace KOLPIN winch parts (including the cable) with KOLPIN replacement parts available at your authorized KOLPIN dealer or the KOLPIN website (Kolpin.com).

 **WARNING**

**NEVER** use a worn or damaged cable. Use of a worn or damaged cable could lead to sudden failure and SEVERE INJURY.

1. Always inspect your winch before each use. Inspect for worn or loose parts including mounting hardware. Never use the winch if any part needs repair or replacement.
2. Always inspect your winch cable before each use. Inspect for worn or kinked winch cable.
  - A. A kinked winch cable made of wire rope is shown at right. Even after being "straightened out," this cable has already been permanently and severely damaged. Promptly discontinue use of a winch cable in this condition.
  - B. A kinked winch cable made of wire rope that has been "straightened out" is shown at right. Even though it may look usable, the cable has been permanently and severely damaged. It can no longer transmit the load that it could prior to kinking. Promptly discontinue use of a winch cable in this condition.
  - C. A winch cable made of synthetic rope should be inspected for signs of fraying. Replace the cable if fraying is observed (shown at right). Promptly discontinue use of a winch cable in this condition.
  - D. Also replace the winch cable if there are fused or melted fibers. Such an area of the synthetic rope will be stiff and appear smooth or glazed. Promptly discontinue use of a winch cable in this condition.

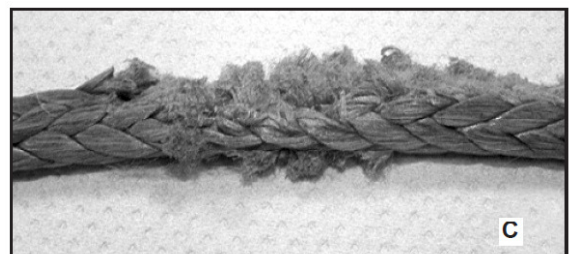
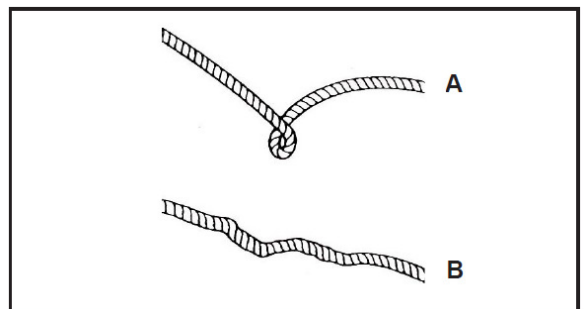

## SHOCK LOADING

 <b>WARNING</b>
<p><b>NEVER</b> shock load a winch cable. Your winch cable is very strong but it is NOT designed for dynamic, or “shock” loading. Shock loading may tension a winch cable beyond its strength and cause the cable to break. The end of a broken winch cable under such high loading can cause SEVERE INJURY or DEATH to you and other bystanders.</p>

*Winch cables are designed to NOT absorb energy. This is true of both wire-rope and synthetic-rope winch cables.*

1. Never attempt to “jerk” a load with the winch. For example, never take up slack in the winch cable by moving the winching vehicle in an attempt to move an object. This is a dangerous practice. It generates high winch cable loads that may exceed the strength of the cable. Even a slowly moving vehicle can create large shock loads in a winch cable.

 <b>WARNING</b>
<p><b>NEVER</b> use a broken winch cable. SEVERE INJURY or DEATH can result.</p>

2. Never quickly turn the winch ON and OFF repeatedly (“jogging”). This puts extra load on the winch, winch cable, and generates excessive heat from the motor. This is a form of shock loading.
3. Never tow a vehicle or other object with your winch. Towing an object with a winch produces shock loading of the cable even when towing at slow speeds. Towing from a winch also positions the towing force high on the vehicle. This can cause instability of the vehicle and possibly lead to an accident.
4. Never use recovery straps with your winch. Recovery straps are designed to stretch and can store energy. This stored energy in the recovery strap is released if a winch cable fails making the event even more hazardous. Similarly, never use elastic “bungee” cords for winching.
5. Never use the winch to tie down a vehicle to a trailer or other transportation vehicle. This type of use also causes shock loading that can cause damage to the winch, winch cable, or vehicles used.
6. ***Your winch cable is designed and tested to withstand the loads produced by the winch motor when operated from a stationary vehicle. Always remember that the winch and winch cable are NOT designed for shock loading.***

## WINCH MAINTENANCE AND SERVICE SAFETY

### **WARNING**

**ALWAYS** follow all winch instructions and warnings in this manual. Improper or lack of winch maintenance and service could lead to SEVERE INJURY or DEATH.

1. Always inspect your winch before each use. Inspect for worn or kinked winch cable. Also inspect for worn or loose parts including mounting hardware.
2. Permit your winch motor to cool down prior to servicing your winch.
3. Never work on your winch without first disconnecting the battery connections to prevent accidental activation of the winch
4. For your safety, always replace KOLPIN winch parts (including the cable) with KOLPIN replacement parts available at your authorized KOLPIN dealer or the KOLPIN website (Kolpin.com).
5. Some winch models use wire rope as the winch cable. Other winches use a specially designed synthetic rope as the winch cable.
6. Never replace a synthetic-rope winch cable with a consumer-grade polymer rope such as can be purchased in a hardware store. Although they may look similar, they are NOT alike. A polymer rope not designed for winch use will stretch and store excessive energy when winching.

### **WARNING**

**ALWAYS** be aware that failure of a stretched rope under winching conditions will release all of the stored energy. This will increase the chances of SEVERE INJURY or DEATH.

## LUBRICATION

All moving parts within the electric winch have been lubricated using high temperature grease at the factory. No internal lubrication is required. Never grease or oil the winch cable. This will cause the winch cable to collect debris that will shorten the life of the cable.

## CABLE ASSEMBLY REPLACEMENT

It is recommended that only KOLPIN supplied parts be used.

1. Move the clutch to the “free-spool” position.
2. Extend cable assembly to its full length. Note how the existing cable is connected to the inside of the drum.
3. Remove old cable assembly and attach new one.
4. Retract cable assembly onto drum being careful not to allow kinking.

### **NOTE**

For service or parts assistance, contact our help line at **1-877-956-5746**.

# PERFORMANCE SPECIFICATIONS

- Motor: 12V DC, permanent magnet type, heavy duty
  - 1.1 HP ..... 2500 lb. rated pull
  - 1.2 HP ..... 3500 lb. rated pull
  - 1.3 HP ..... 4500 lb. rated pull
- Motor duty cycle: Intermittent
- Gear reduction ratio ..... 166 : 1
- Brake: Mechanical
- Electric cable leads ..... 8 gauge (2500 lb. & 3500 lb.), 6 gauge (4500 lb.)
- Winch cable size:
  - 50' length x 3/16" diameter wire rope (3/16" diameter synthetic model) ..... 2500 lb. rated pull
  - 50' length x 7/32" diameter wire rope (3/16" diameter synthetic model) ..... 3500 lb. rated pull
  - 50' length x 7/32" diameter wire rope (1/4" diameter synthetic model) ..... 4500 lb. rated pull
- Drum size: 50mm diameter x 74mm length

**2500 lb. Specifications:**

Line Pull (lbs)	Line Speed (ft/min)	Motor (amps)
0	25	24
500	18	50
1500	15	118
2500	9	210

**3500 lb. Specifications:**

Line Pull (lbs)	Line Speed (ft/min)	Motor (amps)
0	23	24
500	17	56
1500	14	120
2500	9	220
3500	7	240

**4500 lb. Specifications:**

Line Pull (lbs)	Line Speed (ft/min)	Motor (amps)
0	23	29
500	17	60
1500	14	130
2500	9	225
3500	7	260
4500	5	310

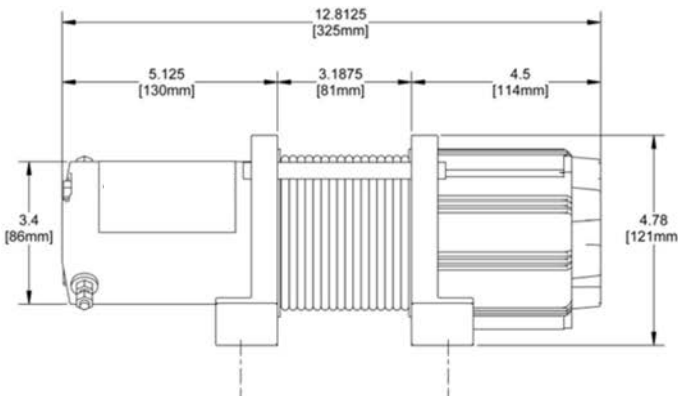

Winch Dimensions - Front View

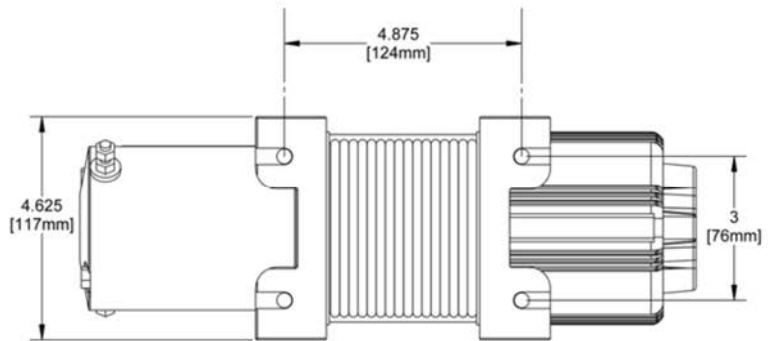

Winch Dimensions - Bottom View

**25-9250 Kit Contents (2500 lb) and Replacement Part Numbers:**

Item	Qty	Part Description	Replacement Part Number
1	1	Replacement Winch 2500#	25-9250R
2	1	Kolpin winch hook strap, orange	85071
3	1	Kolpin steel cable, 3/16" diameter x 50' length	85062
4	1	Rocker switch	85066
5	1	Contactora/solenoid	85068
6	1	Roller fairlead	85069
7	2	Lock washer, M4	-
8	2	Flat washer, M4	-
9	1	Scotch lock	-
10	6	Cable tie, 8"	-
11	2	Hex nut, M4	-
12	8	Flat washer, M8	-
13	4	Hex nut, M8 x 1.25	-
14	4	Lock washer, M8	-
15	6	Hex bolt, M8 x 1.25 x 25mm zinc plated	-
16	2	Hex bolt, M8 x 1.25 x 20mm zinc plated	-
17	6	Terminal cap	RPR0109
18	1	Clevis hook	RPR0108
19	1	Cable, red, 8-gauge, 36"	85089
20	1	Cable, black, 8-gauge, 36"	85089
21	1	Cable, yellow, 8-gauge, 96"	85090
22	1	Cable, blue, 8-gauge, 96"	85090
23	1	Universal Fairlead Mount Bracket	-
24	2	Pan screw, M4 x 30	-

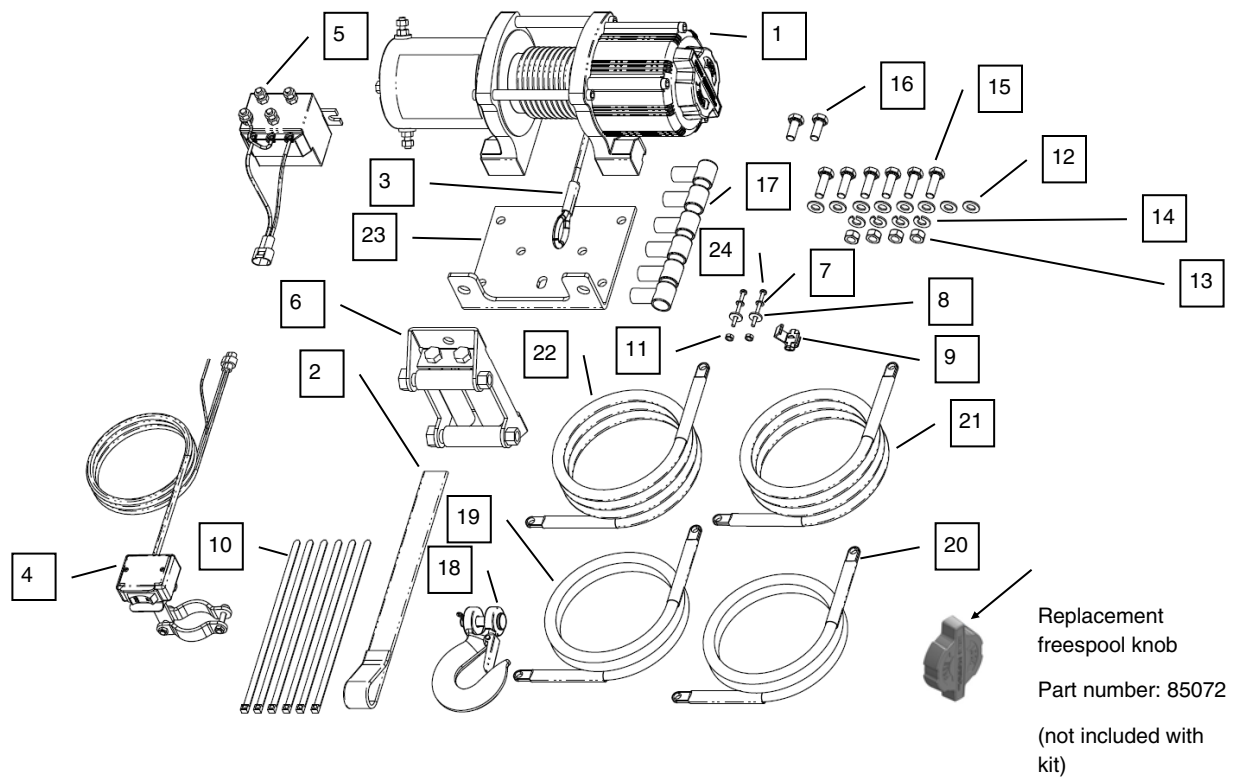

**25-9255 Kit Contents (2500 lb) and Replacement Part Numbers:**

Item	Qty	Part Description	Replacement Part Number
1	1	Replacement Winch 2500#	25-9250R
2	1	Kolpin winch hook strap, orange	85071
3	1	Kolpin synthetic rope, 1/4" diameter x 50' length	85064
4	1	Rocker switch	85066
5	1	Contactor/solenoid	85068
6	1	Roller fairlead	85069
7	2	Lock washer, M4	-
8	2	Flat washer, M4	-
9	1	Scotch lock	-
10	6	Cable tie, 8"	-
11	2	Hex nut, M4	-
12	8	Flat washer, M8	-
13	4	Hex nut, M8 x 1.25	-
14	4	Lock washer, M8	-
15	6	Hex bolt, M8 x 1.25 x 25mm zinc plated	-
16	2	Hex bolt, M8 x 1.25 x 20mm zinc plated	-
17	6	Terminal cap	RPR0109
18	1	Clevis hook	RPR0108
19	1	Cable, red, 8-gauge, 36"	85089
20	1	Cable, black, 8-gauge, 36"	85089
21	1	Cable, yellow, 8-gauge, 96"	85090
22	1	Cable, blue, 8-gauge, 96"	85090
23	1	Winch Stop	85080
24	1	Universal Fairlead Mount Bracket	-
25	2	Pan screw, M4 x 30	-

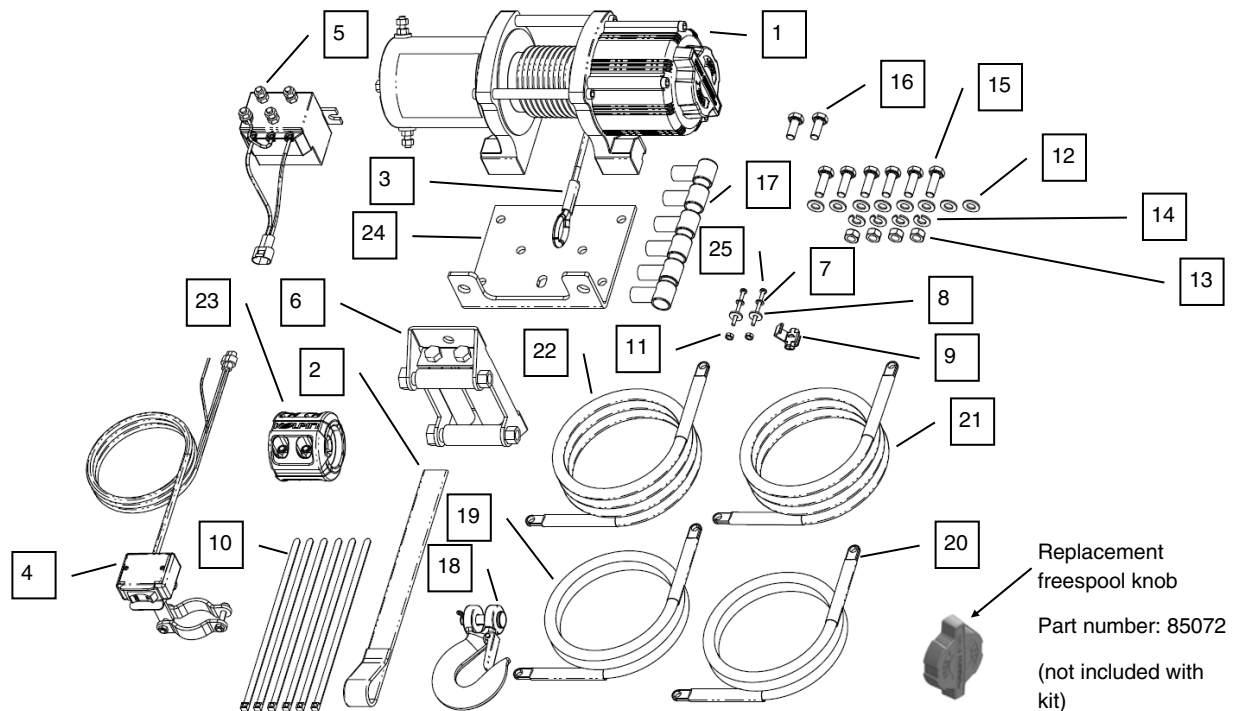



**25-9350 Kit Contents (3500 lb) and Replacement Part Numbers:**

Item	Qty	Part Description	Replacement Part Number
1	1	Replacement Winch 3500#	25-9350R
2	1	Kolpin winch hook strap, orange	85071
3	1	Kolpin steel cable, 7/32" diameter x 50' length	85063
4	1	Rocker switch	85066
5	1	Contactora/solenoid	85068
6	1	Roller fairlead	85069
7	2	Lock washer, M4	-
8	2	Flat washer, M4	-
9	1	Scotch lock	-
10	6	Cable tie, 8"	-
11	2	Hex nut, M4	-
12	8	Flat washer, M8	-
13	4	Hex nut, M8 x 1.25	-
14	4	Lock washer, M8	-
15	6	Hex bolt, M8 x 1.25 x 25mm zinc plated	-
16	2	Hex bolt, M8 x 1.25 x 20mm zinc plated	-
17	6	Terminal cap	RPR0109
18	1	Clevis hook	RPR0108
19	1	Cable, red, 8-gauge, 36"	85089
20	1	Cable, black, 8-gauge, 36"	85089
21	1	Cable, yellow, 8-gauge, 96"	85090
22	1	Cable, blue, 8-gauge, 96"	85090
23	1	Corded Remote Switch	85067
24	1	Universal Fairlead Mount Bracket	-
25	2	Pan screw, M4 x 30	-

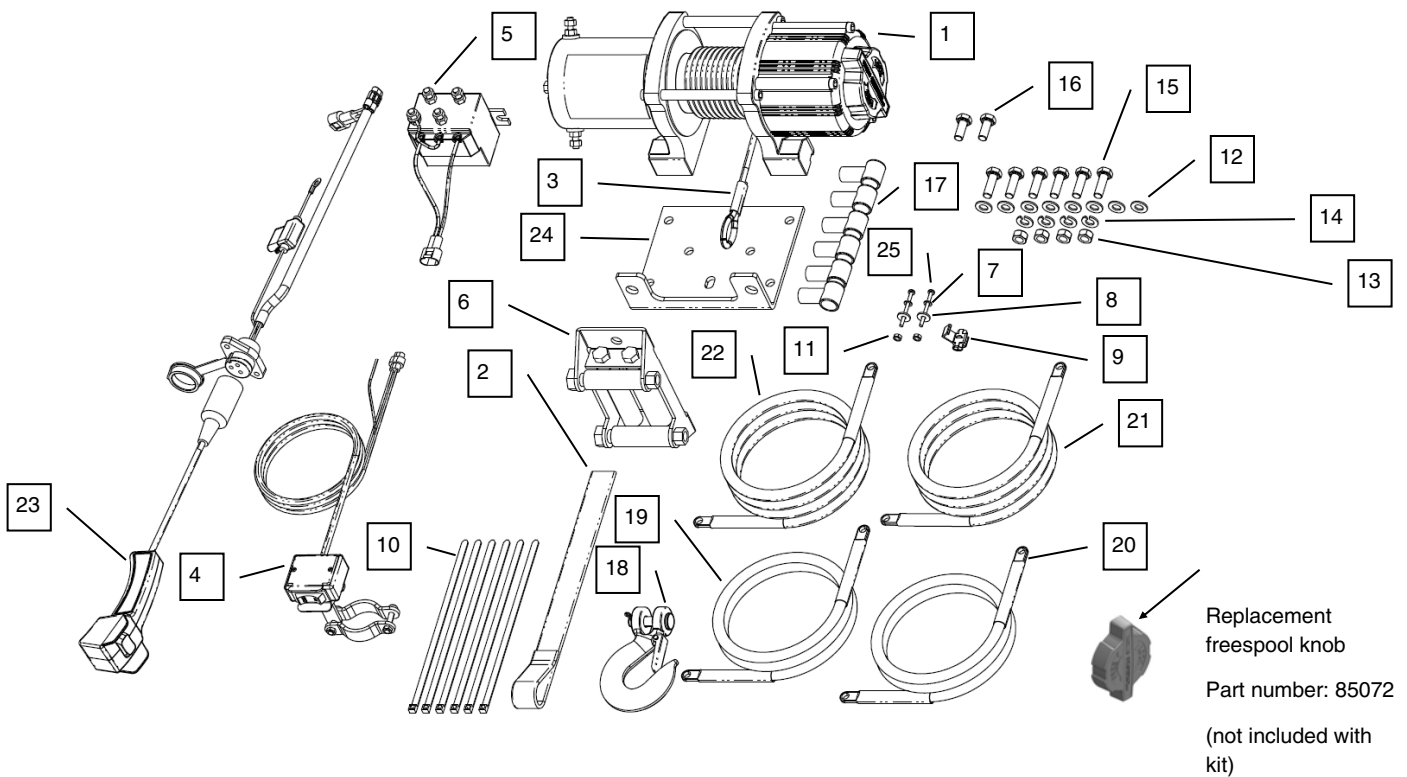



**25-9355 Kit Contents (3500 lb) and Replacement Part Numbers:**

Item	Qty	Part Description	Replacement Part Number
1	1	Replacement Winch 3500#	25-9350R
2	1	Kolpin winch hook strap, orange	85071
3	1	Kolpin synthetic rope, 1/4" diameter x 50' length	85064
4	1	Rocker switch	85066
5	1	Contactor/solenoid	85068
6	1	Roller fairlead	85069
7	2	Lock washer, M4	-
8	2	Flat washer, M4	-
9	1	Scotch lock	-
10	6	Cable tie, 8"	-
11	2	Hex nut, M4	-
12	8	Flat washer, M8	-
13	4	Hex nut, M8 x 1.25	-
14	4	Lock washer, M8	-
15	6	Hex bolt, M8 x 1.25 x 25mm zinc plated	-
16	2	Hex bolt, M8 x 1.25 x 20mm zinc plated	-
17	6	Terminal cap	RPR0109
18	1	Clevis hook	RPR0108
19	1	Cable, red, 8-gauge, 36"	85089
20	1	Cable, black, 8-gauge, 36"	85089
21	1	Cable, yellow, 8-gauge, 96"	85090
22	1	Cable, blue, 8-gauge, 96"	85090
23	1	Winch Stop	85080
24	1	Corded Remote Switch	85067
25	1	Universal Fairlead Mount Bracket	-
26	2	Pan screw, M4 x 30	-

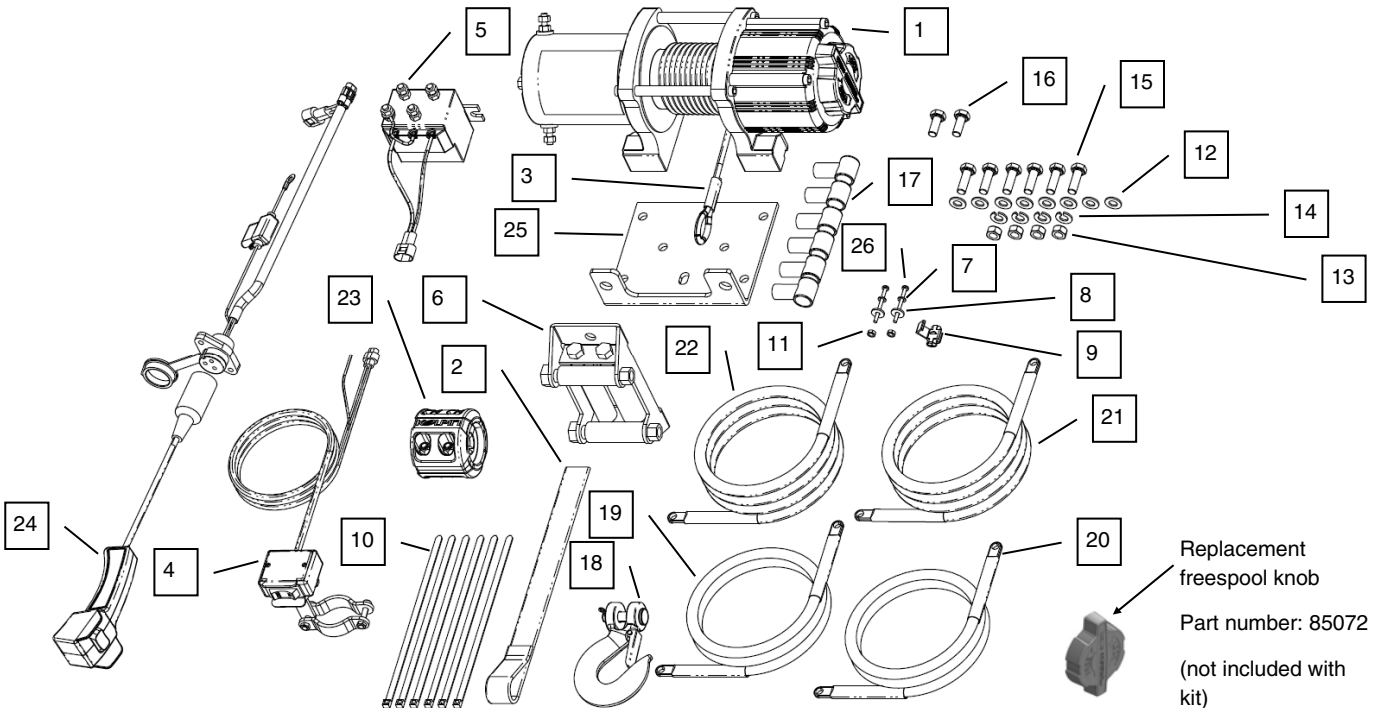

**25-9450 Kit Contents (4500 lb) and Replacement Part Numbers:**

Item	Qty	Part Description	Replacement Part Number
1	1	Replacement Winch 4500#	25-9450R
2	1	Kolpin winch hook strap, orange	85071
3	1	Kolpin steel cable, 7/32" diameter x 50' length	85063
4	1	Rocker switch	85066
5	1	Contactora/solenoid	85068
6	1	Roller fairlead	85069
7	2	Lock washer, M4	-
8	2	Flat washer, M4	-
9	1	Scotch lock	-
10	6	Cable tie, 8"	-
11	2	Hex nut, M4	-
12	8	Flat washer, M8	-
13	4	Hex nut, M8 x 1.25	-
14	4	Lock washer, M8	-
15	6	Hex bolt, M8 x 1.25 x 25mm zinc plated	-
16	2	Hex bolt, M8 x 1.25 x 20mm zinc plated	-
17	6	Terminal cap	RPR0109
18	1	Clevis hook	RPR0108
19	1	Cable, red, 6-gauge, 36"	85089
20	1	Cable, black, 6-gauge, 36"	85089
21	1	Cable, yellow, 6-gauge, 96"	85090
22	1	Cable, blue, 6-gauge, 96"	85090
23	1	Corded Remote Switch	85067
24	1	Dash Mount Bracket	85082
25	1	Universal Fairlead Mount Bracket	-
26	2	Pan screw, M4 x 30	-

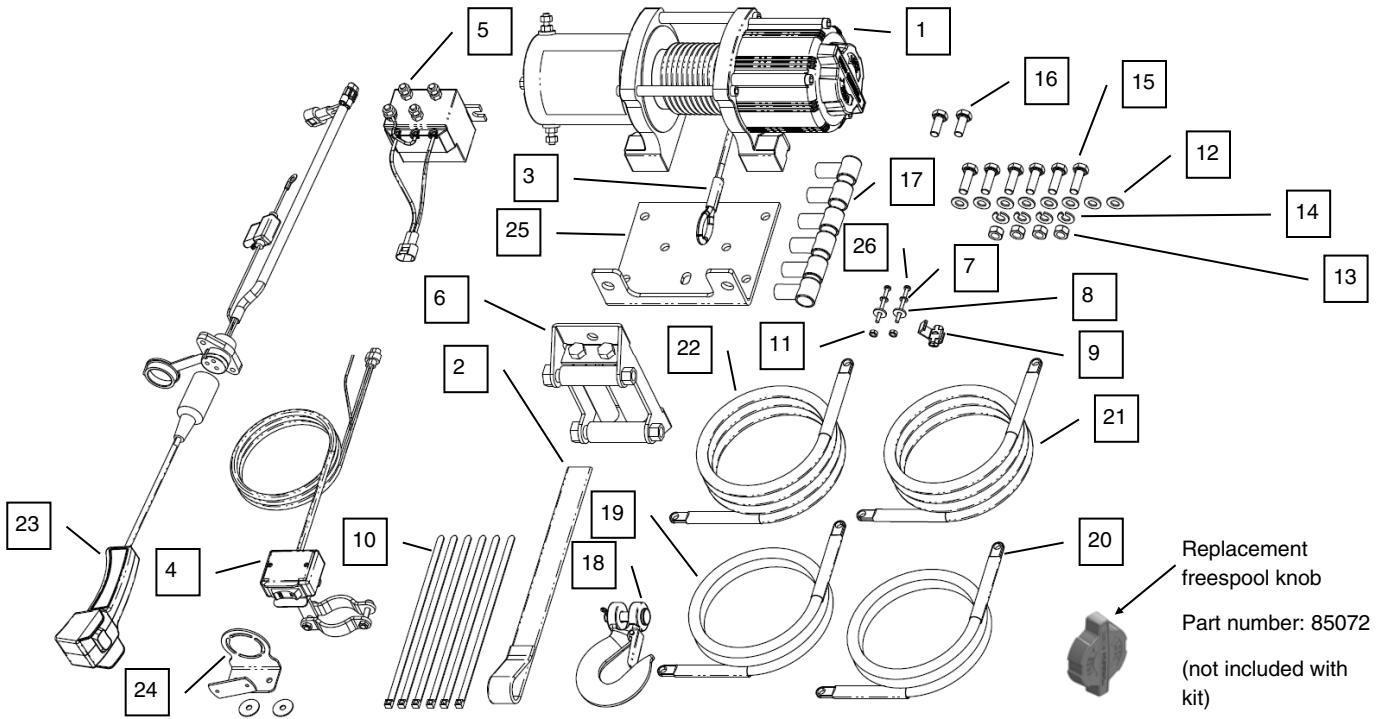

**25-9455 Kit Contents (4500 lb) and Replacement Part Numbers:**

Item	Qty	Part Description	Replacement Part Number
1	1	Replacement Winch 4500#	25-9450R
2	1	Kolpin winch hook strap, orange	85071
3	1	Kolpin synthetic rope, 1/4" diameter x 50' length	85064
4	1	Rocker switch	85066
5	1	Contactor/solenoid	85068
6	1	Roller fairlead	85069
7	2	Lock washer, M4	-
8	2	Flat washer, M4	-
9	1	Scotch lock	-
10	6	Cable tie, 8"	-
11	2	Hex nut, M4	-
12	8	Flat washer, M8	-
13	4	Hex nut, M8 x 1.25	-
14	4	Lock washer, M8	-
15	6	Hex bolt, M8 x 1.25 x 25mm zinc plated	-
16	2	Hex bolt, M8 x 1.25 x 20mm zinc plated	-
17	6	Terminal cap	RPR0109
18	1	Clevis hook	RPR0108
19	1	Cable, red, 6-gauge, 36"	85089
20	1	Cable, black, 6-gauge, 36"	85089
21	1	Cable, yellow, 6-gauge, 96"	85090
22	1	Cable, blue, 6-gauge, 96"	85090
23	1	Winch Stop	85080
24	1	Corded Remote Switch	85067
25	1	Dash Mount Bracket	85082
26	1	Universal Fairlead Mount Bracket	-
27	2	Pan screw, M4 x 30	-

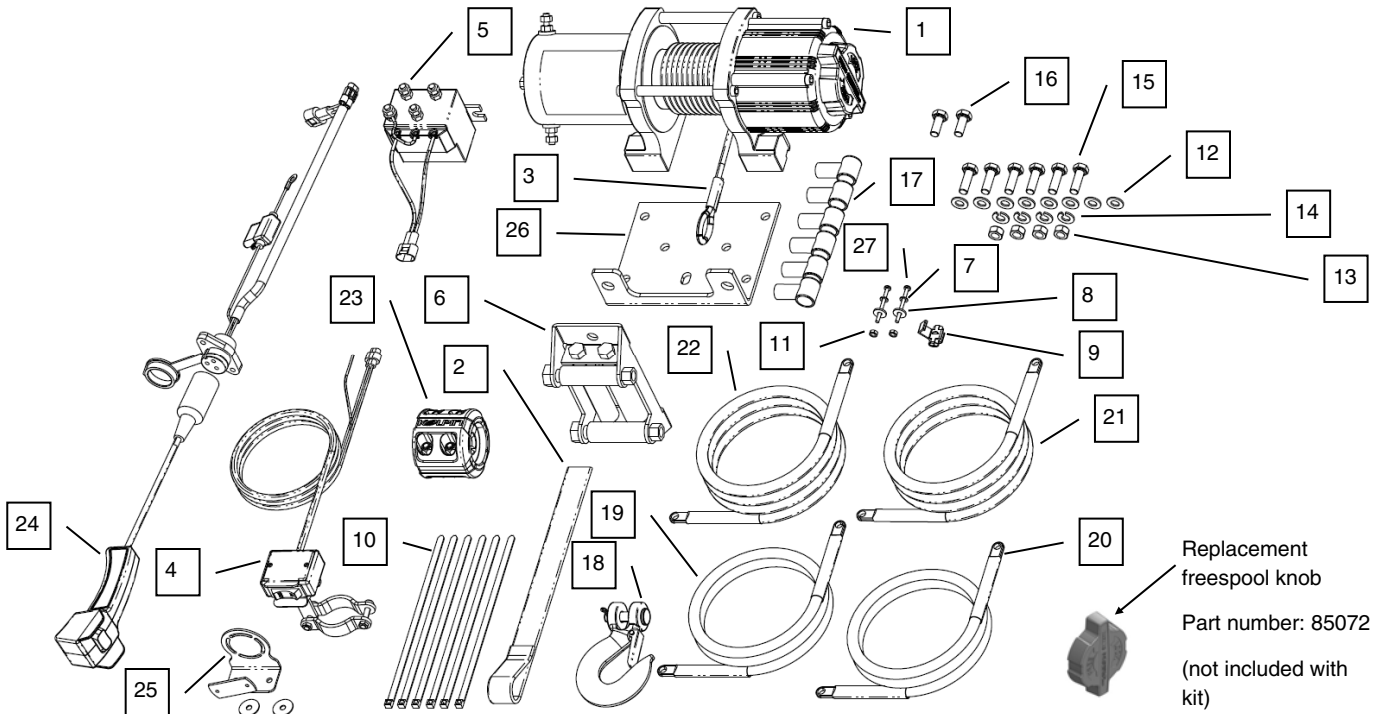

## TROUBLESHOOTING

Problem	Cause	Solution
Motor does not turn	Switch assembly not connected properly	Insert switch assembly all the way into the connector.
	Loose battery cable connections	Tighten nuts on all cable connections.
	Contactor malfunctioning	Tap contactor to loosen contacts. Apply 12 volts to coil terminals directly. A clicking indicates proper activation.
	Defective switch assembly	Replace switch assembly.
	Defective motor	Check for voltage at armature port with switch pressed. If voltage is present, replace winch assembly.
	Nested and bounded cable within winch assembly	Move freespool knob to the "free spool" position. Manually pull cable out of winch until end is met and then re-spool cable back into winch.
	Water has entered motor	Allow to drain and dry. Run in short bursts without load until completely dry.
Motor runs but cable drum does not turn	Clutch (freespool knob) not engaged	Move freespool knob to the "locked spool" position. If problem persists, a qualified technician needs to check and repair.
Motor runs slowly or without normal power	Insufficient current or voltage	The battery is weak, recharge. Run winch with vehicle motor running (battery should have a strong charge).
	Loose or corroded battery cable connections	Clean, tighten, or replace.
Motor overheating	Winch running time too long	Allow winch to cool down periodically.
Motor runs in one direction only	Defective or stuck contactor	Tap contactor to loosen contacts.
		Repair or replace contactor.
	Defective switch assembly	Replace switch assembly.
	Defective brake assembly	Replace winch assembly.

***Note: If any hardware is missing, do not return to the store. Call us to help, Toll Free 1-877-956-5746.***

### NOTE

For further technical support, contact our help line at **1-877-956-5746**.



## **Five Year Mechanical Limited Warranty and Three Year Electrical Limited Warranty**

For the period of five (5) years from the purchase date, Kolpin will replace for the original purchaser, free of charge, any mechanical part or mechanical parts found upon examination by Kolpin to be defective in material, workmanship, or both. For the period of three (3) years from the purchase date, Kolpin will replace for the original purchaser, free of charge, any electrical part or electrical parts found upon examination by Kolpin to be defective in material, workmanship, or both.

All transportation costs incurred submitting product to Kolpin for warranty consideration must be borne by the purchaser. If Kolpin determines that the product must be returned to the factory for credit, please call 1-877-956-5746 for a Return Merchandise Authorization (RMA) number and shipping instructions.

This warranty does not apply to parts that have been damaged by accident, alteration, abuse, improper maintenance, normal wear, or other causes beyond the manufacturer's control. In order to protect you and your ATV, certain parts of the winch/plow system and/or hardware are designed to fail when the equipment is over-stressed. Parts that are lost due to loosening and improper maintenance are not covered under warranty. This warranty does not cover removal or reinstallation labor fees of the winch/plow system and related components.

Peripheral products such as engines, electric motors, and actuators may carry an original manufacturer's warranty. Most hardware is general in nature and is easily obtained locally. Be sure to replace with minimum metric class 8.8 specification.

**Kolpin Outdoors, Inc.**

**Telephone: (763)-478-5800**

**Toll Free: (877)-956-5746**

**Fax Number: (800)-245-7569**

**[www.kolpin.com](http://www.kolpin.com)**

**Email: [customerservice@kolpin.com](mailto:customerservice@kolpin.com)**

# **KOLPIN<sup>®</sup>** **OUTDOORS**

**2500 lb / 3500 lb / 4500 lb**

## **ATV / UTV WINCH KIT**

**P/Ns: 25-9250, 25-9255, 25-9350, 25-9355, 25-9450, 25-9455**

**OWNER'S / OPERATING INSTRUCTIONS / SPARE PARTS**

Application

WINCH MOUNT NO. 25-XXXX, OEM VEHICLE WINCH MOUNTS

Before you begin, please read these instructions and check to be sure all parts and tools are accounted for. The following instructions contain details required to operate, install and service the contents of this kit. Save these instructions. Important safety instructions are included in this manual.



# **TABLE OF CONTENTS**

## **Introduction**

Introduction .....	3
Guidebook Conventions .....	3

## **Controls and Features** .....

4

Winch .....	4
-------------	---

## **Assembly** .....

5

Mounting .....	5
Mounting the winch .....	5
Mounting the handlebar switch .....	6
Mounting the contactor/solenoid .....	6
Mounting the remote switch (optional) .....	7

Wiring the winch .....	7
Winch Wiring diagram .....	8
Corded Remote and Rocker Switch Wiring Diagram .....	9

## **ATV/UTV Winch User Guide** .....

10

Winch Safety Precautions .....	10-11
Winch Operation .....	12-14
Wire Cable Care .....	14
Shock loading .....	15

## **Winch Maintenance and Service Safety** .....

16

Lubrication .....	16
Cable Assembly Replacement .....	16

## **Specifications** .....

17

Performance Specifications .....	17
Parts Kit Diagrams and replacement part numbers .....	18-23

## **Troubleshooting** .....

24

## **Warranty** .....

25

## INTRODUCTION

Congratulations on your purchase of a Kolpin winch! The Kolpin winch works great for vehicle recovery and plow lift applications. With proper use and maintenance, this winch will bring many years of satisfying service.

Every effort has been made to ensure the accuracy and completeness of the information in this manual. We reserve the right to change, alter and/or improve the product and this document at any time without prior notice.

Record the part numbers, date of purchase and place of purchase for future reference. Please have this information available when ordering parts and when making technical or warranty inquiries.

<b>Kolpin Outdoors Support</b>
1-877-956-5746
<b>Part Number</b>
<b>Date of Purchase</b>
<b>Purchase Location</b>

## GUIDEBOOK CONVENTIONS

This manual uses the following symbols to help differentiate between different kinds of information. The safety symbol is used with a signal word to alert you to potential hazards in operating and owning power equipment. Follow all safety messages to avoid or reduce the risk of serious injury or death. Each message has a specific purpose. **PLEASE WORK SAFELY!**

 <b>WARNING</b>
<b>WARNING</b> indicates a potentially hazardous situation that, if not avoided, could result in death or serious injury.

<b>NOTICE</b>
<b>NOTICE</b> indicates a potentially hazardous situation which, if not avoided, may result in property damage.

 <b>CAUTION</b>
<b>CAUTION</b> indicates a potentially hazardous situation that, if not avoided, may result in minor or moderate injury.

<b>NOTE</b>
If you have questions regarding your winch, we can help. Please call our help line at <b>1-877-956-5746</b> .



# CONTROLS AND FEATURES

Read this owner's manual before operating your winch. Familiarize yourself with the location and function of the controls and features. Save this manual for future reference. Some features may not exist on all models, but can be ordered as options, please contact technical services at **1-877-956-5746**.

## WINCH

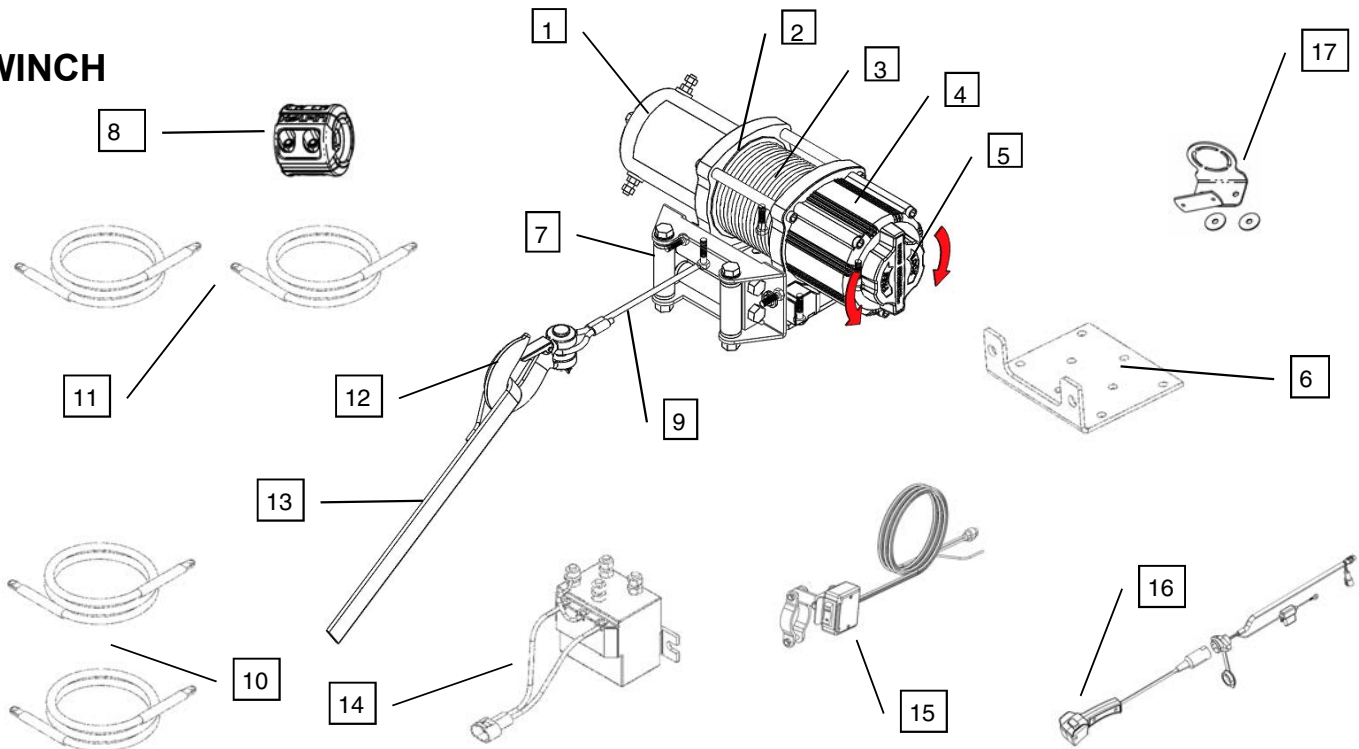

- (1) **Motor:** 12V DC motor provides power to the planetary gear mechanism.
- (2) **Braking System:** Braking action is automatically applied to the winch drum when the winch motor is stopped and there is a load on the winch cable.
- (3) **Winch Drum:** The winch drum is the cylinder on which the wire rope is stored. It can feed or wind the rope depending on the remote winch switch signal.
- (4) **Planetary Gear System:** The reduction gears convert the winch motor power into extreme pulling forces. This system allows high torque while maintaining compact size and light weight.
- (5) **Free Spooling Clutch:** The clutch allows the operator to manually disengage "Out" the spooling drum from the gear train, free spool. Engaging the clutch "In" locks the winch into the gear system.
- (6) **Mount Assembly:** Flatbed mounting channel.
- (7) **Roller Fairlead:** When using the winch at an angle, the roller fairlead acts to guide the wire rope onto the drum and minimizes damage to the wire rope from abrasion on the winch mount or bumper.
- (8) **Rubber Winch Stop:** Increases life of cables, ropes and fairleads. Quiets hook rattling noise.
- (9) **Rope:** Galvanized steel aircraft cable or synthetic rope designed specifically for winch load capacities.
- (10) **Winch Connection Cables:** Used to connect the contactor to the winch motor.
- (11) **Battery Connection Cables:** Used to connect the battery to the contactor.
- (12) **Clevis Hook:** Provides a means for connecting the looped ends of cables to an anchor.
- (13) **Strap:** Used to assist cable feed.
- (14) **Contactor/solenoid:** Power from the vehicle battery flows through the weather sealed contactor/solenoid switch before being directed to the winch motor.
- (15) **Rocker Switch:** Rocker switch with handlebar mount for powering the rope in or out of your winch drum.
- (16) **Corded Remote Switch:** Corded remote switch allows the operator to stand clear during the winching process.
- (17) **Dash Mount Bracket:** Bracket allows the handlebar rocker switch to be installed onto a dash surface.

# ASSEMBLY

The winch kit comes mostly assembled from the factory. Some pre-assembly of the kit is required for installation into vehicles.

## BEFORE YOU BEGIN:

- Your Kolpin accessory is designed for a universe fit for most vehicles.
- Please read and understand all instructions.
- Verify all parts and tools are accounted for.
- To ensure a satisfactory installation, follow all steps correctly and in the sequence described.
- To facilitate installation, make sure that your vehicle is clean and free of debris.
- All directions referring to right and left are when the rider is sitting on the machine.

## TOOLS REQUIRED:

- Basic metric wrench set
- Basic metric socket set
- Pliers
- Philips screwdriver

## MOUNTING THE WINCH

- If using a winch mounting kit, refer to the kit's manual for specific installation instructions. *See Kolpin.com for a full assortment of custom winch mounts for ATV/UTVs.*
- Mount the winch to the mount plate (not included) as shown below. Rotate the lock knob to the free spool position and feed the winch cable through the rollers of the roller fairlead.
- Mount the roller fairlead plate and attach the hook clevis and nylon pull strap. Rotate the lock knob back to the lock position.

**! WARNING**  
ALWAYS use supplied hook strap.

## NOTICE

ALWAYS ensure that the 3 major sections (motor, drum, gear housing) are properly aligned if utilizing a mounting plate. Proper alignment of the winch will allow for even distribution of the full rated load.

Roller fairlead or aluminum hawse (orientate warning label to face upwards or outwards so it is visible when viewing from front of vehicle)

Clevis hook

Nylon strap

**Note: If any hardware is missing, do not return to the store. Call us to help, Toll Free 1-877-956-5746.**

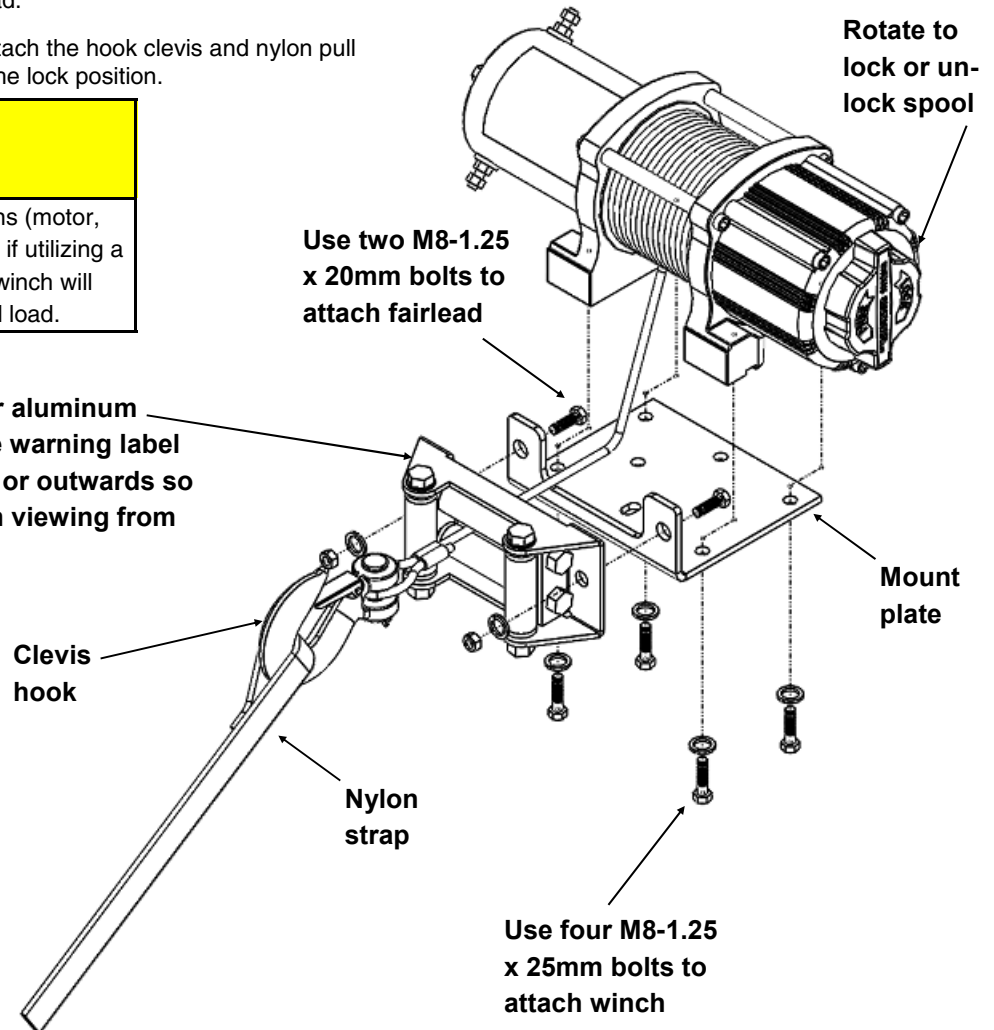

## MOUNTING THE HANDLEBAR SWITCH

- Install the rocker switch to the handlebar using the hardware included in this kit as shown below.
- It is recommended that the switch be installed on the left handlebar. Exact position may vary depending on vehicle.
- Use a piece of electrical tape (not provided) around the handlebar to help prevent rotation of the switch bracket mount.
- Tighten the rocker switch in place. DO NOT overtighten or tighten/clamp over any hose, wiring or cables.
- Once the rocker switch is mounted, the wires can be routed to the contactor/solenoid location.
- Make sure the handlebars have full range of motion, vehicle switches/brakes/throttle can move freely, and then secure the rocker switch's cable with the supplied cable ties.
- Using the provided wire splice, splice the end of the red 20ga wire to a key controlled, fused, accessory circuit (power point) of the ATV/UTV. The wire should only have power when the key is in the "ON" position.

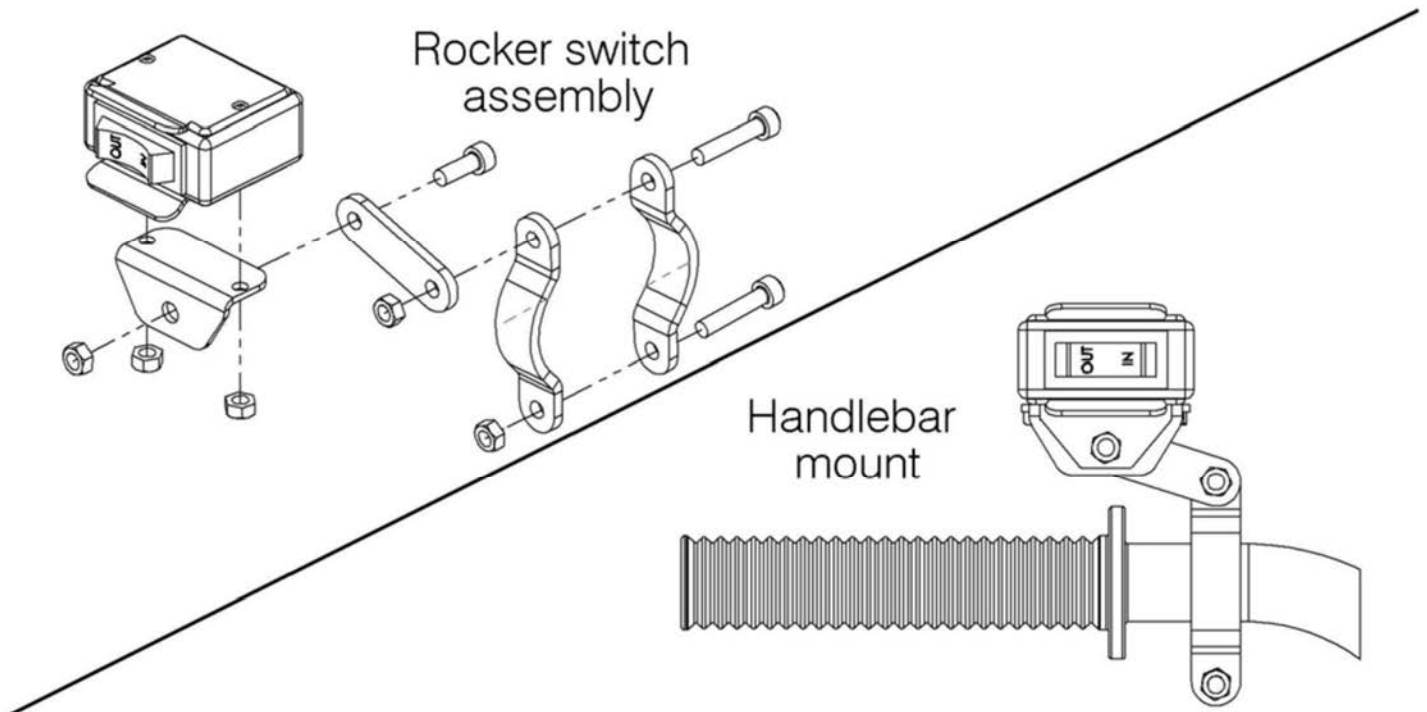

## MOUNTING THE CONTACTOR/SOLENOID

- The contactor/solenoid is a primary safety feature in the winch system. It disconnects the winch from its power source when the vehicle is not in use. The contactor/solenoid must be correctly installed to work properly.
- Find a location for the contactor/solenoid. It is recommended that the contactor/solenoid be mounted close to the battery in a clean, dry location. The exact location of the contactor/solenoid will vary depending on the vehicle. Make sure the location chosen allows for sufficient clearance from all metal components such as frame tubes. DO NOT place tools or other items in a position that might come in contact with the contactor/solenoid posts.
- Drill mounting holes if required. Secure the contactor/solenoid using the provided hardware.
- Once a location is found for the contactor/solenoid, DO NOT install the unit until all wiring is completed (see wiring section). Pre-fit all wiring to confirm its long enough to reach the battery and the winch contact locations.

**! WARNING**

**NEVER** short battery terminals with metal objects. Be aware terminals in contact with metal will cause a direct short, possibly causing contactor/ solenoid

## MOUNTING THE REMOTE SWITCH

### (optional on some models)

- Determine the mounting location for the remote socket. Exact position may vary depending on vehicle. Drill three holes and install to vehicle dash panel or body panel.
- Route the wire harness to where the contactor/solenoid will be mounted. Secure the socket's cable with the supplied cable ties.
- Using the provided wire splice, splice the end of the red 20ga wire to a key controlled, accessory circuit (power-point) of the ATV/UTV or use the provided 20ga wire eyelet terminal connector to connect to a vehicle terminal strip post. The wire should only have power when the key is in the "ON" position.
- **NOTE: If installing both switches (handlebar rocker and corded remote), both 20ga red wires must be connected together with the provided plug connectors or spliced to a key-controlled accessory circuit of the ATV/UTV as described in the above step.**

## NOTICE

**ALWAYS** make sure to splice into keyed accessory wire that has power when key is turned on. You may need to use a test light to locate a suitable wire.

## WIRING THE WINCH

- Install the wiring using the diagram on the next page.
- Slip terminal boots on yellow and blue cable ends. Connect the yellow and blue cables to the color-matched motor terminals on the winch. Tighten the terminal nuts on the motor. **DO NOT** overtighten. Seat boots over terminal. Route the other ends to the contactor/solenoid location.
- Connect the yellow and blue cables to the contactor/solenoid (yellow to yellow and blue to blue). **DO NOT** tighten nuts or seat boots at this time.
- Slip terminal boots on the ring terminal ends of the black and red cables. Connect the black and red cables to the contactor/solenoid (red to red and black to black). **DO NOT** tighten nuts or seat boots at this time. Route red and black cables to battery. **DO NOT** connect cables to battery at this time.
- **Mount the contactor to the location planned in the previous steps with provided hardware. Tighten the contactor/solenoid mounting fasteners. DO NOT overtighten.**
- Adjust cables to facilitate orderly and straight routing of the cables from the contactor/solenoid. Avoid kinks or sharp bends in the cables. Avoid crossing cables over each other for at least the first 6" of cable starting from the contactor/solenoid post. Tighten the contactor/solenoid terminal nuts. **DO NOT** over tighten. Seat terminal boots over ring terminals and posts.
- Connect the rocker switch to the contactor/solenoid using the provided plug. Splice the end of the red wire on the rocker switch, to a vehicle accessory circuit controlled by ignition controlled power source (keyed). The wire should only have power when the key is in the "ON" position.
- Carefully inspect battery and winch electrical cable routing to ensure it is neat and tidy. Secure electrical cables and wiring harnesses with provided cable ties. Cable ties should be snug, but not cutting into wire insulation. Use electrical tape, pieces of rubber hose or electrical conduit to protect electrical cables and wire harnesses where needed to avoid electrical cable insulation wear or abrasion.
- Connect the red lead to the positive (+) terminal of the vehicle's 12 volt battery first. Connect the black lead to the negative (-) terminal of the vehicle's 12 volt battery second. Install protective boots as appropriate to protect connection. Tighten battery terminal fasteners as directed in the vehicle service manual to the proper torque specification.
- Check for proper drum rotation. Pull and turn the clutch knob to the "free spool" position. Pull out some cable from the drum, and then turn the clutch knob to the "locked spool" position to engage the gears. Press the cable out button on the rocker switch. If the drum is turning and releasing more cable, your connections are accurate. If the drum is turning and collecting more cable, then reverse the leads on the motor. Repeat and check rotation.
- With some applications, the motor terminal posts may need to be rotated to avoid interference with other components.

## CAUTION

**NEVER** route electrical cables across any sharp edges, through and /or near moving parts, or near parts that may become hot.

## CAUTION

**ALWAYS** leave some slack for electrical cable movement. Battery cables should **NOT** be drawn taut.

# WINCH WIRING DIAGRAM

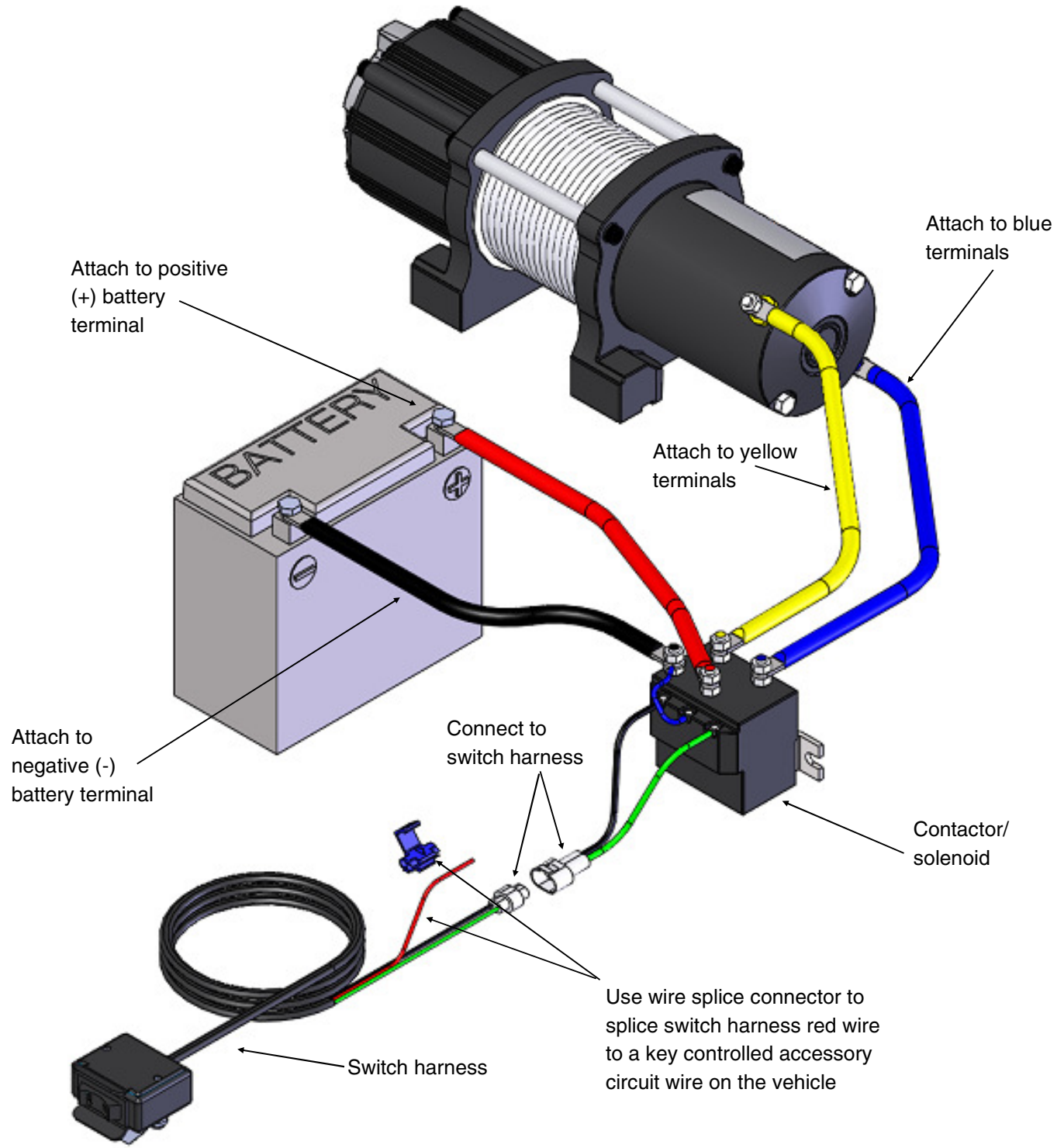



# CORDED REMOTE AND ROCKER SWITCH WIRING DIAGRAM

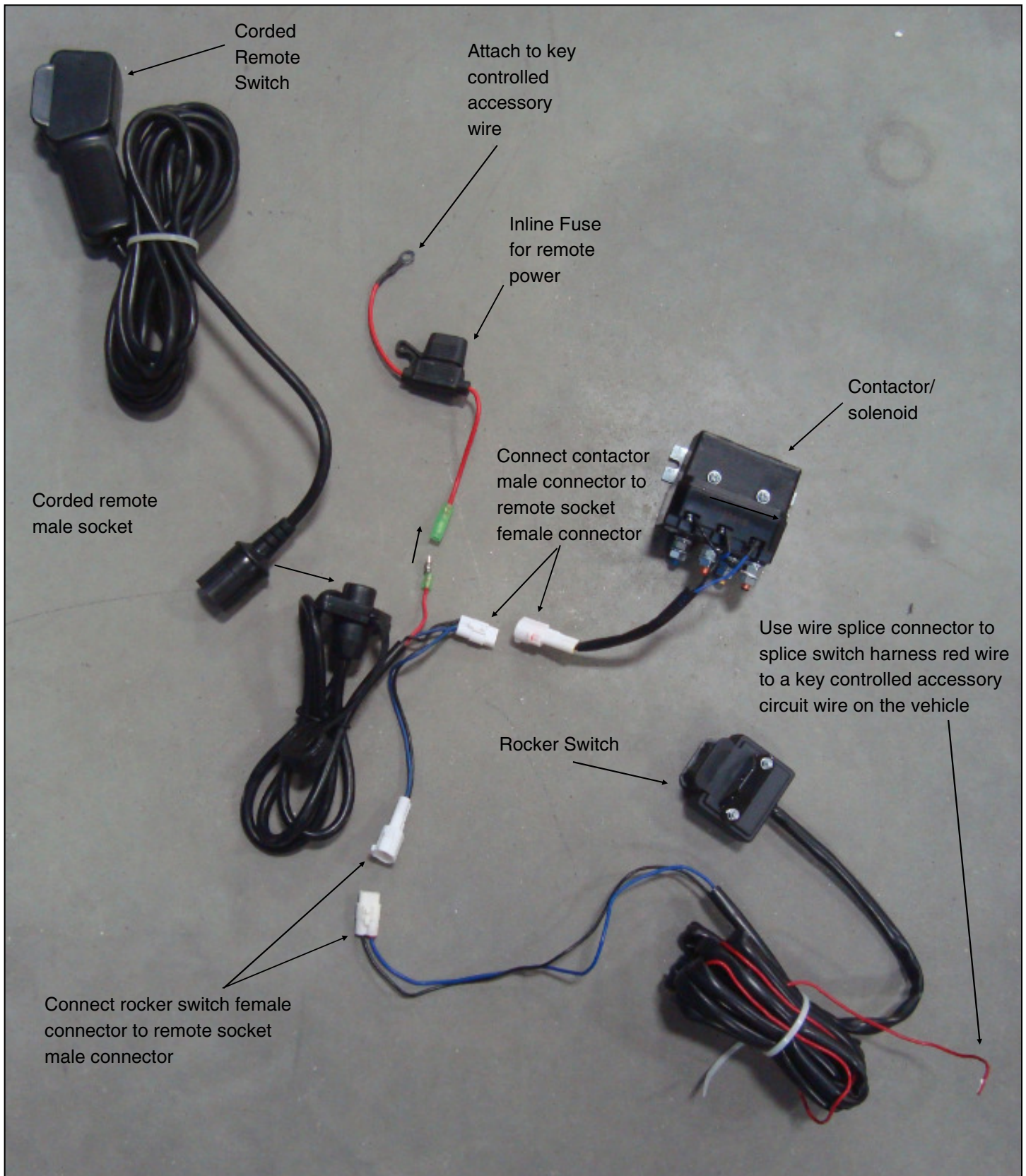

# ATV/UTV WINCH USER GUIDE

Before you begin using your winch, read and understand the guide. Please retain this guide for future reference.

These safety warnings and instructions apply if you choose to add an accessory winch to your vehicle.



Your winch may have a cable made of either wire rope or specially designed synthetic rope. The term “winch cable” will be used for either unless noted otherwise.

## WINCH SAFETY PRECAUTIONS

1. Read all sections of this manual.
2. Never use alcohol or drugs before or while operating the winch.
3. Never allow children under 16 years of age to operate the winch.
4. Always wear eye protection and heavy gloves when operating the winch.
5. Always keep body, hair, clothing and jewelry clear of the winch cable, fairlead and hook when operating winch.
6. Never attempt to “jerk” a load attached to the winch with a moving vehicle. See the **Shock Loading** section on page 15.
7. Always keep the area around the vehicle, winch, winch cable and load clear of people (especially children) and distractions while operating the winch.
8. Always turn the vehicle ignition power OFF when it and the winch are not being used.
9. Always be sure that at least five full turns of winch cable are wrapped around the winch drum at all times. The friction provided by this wrapped cable allows the drum to pull on the winch cable and move the load.
10. Always apply your vehicle’s park brake and/or park mechanism to hold the vehicle in place during winching. Use wheel chocks if needed.
11. Always align the vehicle and winch with the load directly in front of the vehicle as much as possible. Avoid winching with the winch cable at an angle to the winching vehicle’s center line whenever possible.
12. If winching at an angle is unavoidable, follow these precautions:
  - A. Look at the winch drum occasionally. Never let the winch cable “stack” or accumulate at one end of the winch drum. Too much winch cable at one end of the winch drum can damage the winch and the winch cable.
  - B. If stacking occurs, stop winching. Follow step 15 on page 4 to feed and rewind the cable evenly before continuing the winch operation.
13. Never winch up or down at sharp angles. This can destabilize the winching vehicle and possibly cause it to move without warning.
14. Never attempt to winch loads that weigh more than the winch’s rated capacity.
15. The winch motor may become hot during winch use. If you winch for more than 45 seconds, or if the winch stalls during operation, stop winching and permit the winch to cool down for 10 minutes before using it again.

## WINCH SAFETY PRECAUTIONS (continued)

16. Never touch, push, pull or straddle the winch cable while winching a load.
17. Never let the winch cable run through your hands, even if wearing heavy gloves.
18. Never release the clutch on the winch when the winch cable is under load.
19. Never use the winch for lifting or transporting people.
20. Never use the winch to hoist or suspend a vertical load.
21. Never immerse or submerge your winch in water. Take your winch to your dealer for service if this occurs.
22. Always inspect your winch and winch cable before each use.
23. Never winch the hook fully into the winch. This can cause damage to winch components.
24. Unplug the remote control from the vehicle when the winch is not in use to prevent inadvertent activation and use by unauthorized persons.
25. Never grease or oil the winch cable. This will cause the winch cable to collect debris that will shorten the life of the cable.

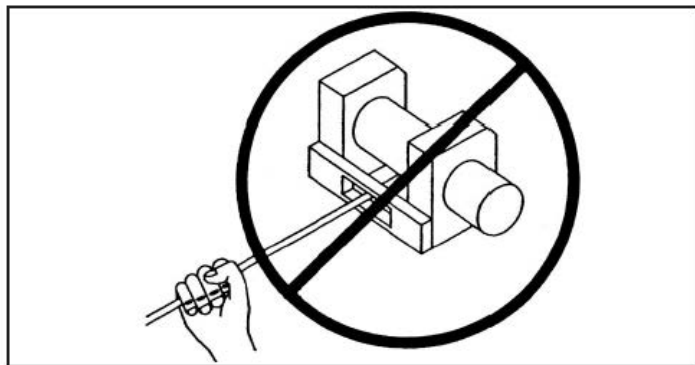



## WINCH OPERATION

Read the *Winch Safety Precautions* in the preceding pages before using your winch.

**TIP:** Consider practicing the operation and use of your winch before you actually need to use it in the field.

 **WARNING**

**ALWAYS** follow all winch instructions and warnings in this manual. Improper winch use can result in SEVERE INJURY or DEATH.

Each winching situation is unique:

- Take your time to think through the winching you are about to do.
  - Proceed slowly and deliberately.
  - Never hurry or rush during winching.
  - Always pay attention to your surroundings.
  - You may need to change your winching strategy if it is not working.
  - Always remember that your winch is very powerful.
  - There are simply some situations that you and your winch will not be able to deal with. Do not be afraid to ask others to help when this happens.
1. Always inspect the vehicle, winch, winch cable and winch controls for any signs of damage or parts in need of repair or replacement before each use. **Pay particular attention to the first three feet (one meter) of the winch cable if the winch is being used (or has been used) for lifting an accessory plow assembly.** Promptly replace any worn or damaged cable.
  2. Never operate a winch or a vehicle in need of repair or service.
  3. Always apply your vehicle's parking brake and/or park mechanism to hold the vehicle in place during winching. Use wheel chocks if needed.
  4. Always use the hook strap when handling the hook.

 **WARNING**

**NEVER** put your fingers into the hook. This could lead to SEVERE INJURY.

- A. Attach the hook itself onto the load or use a tow strap or chain to secure the load to the winch cable.

**TIP:** A "tow strap" is NOT intended to stretch. A "recovery strap" is designed to stretch.

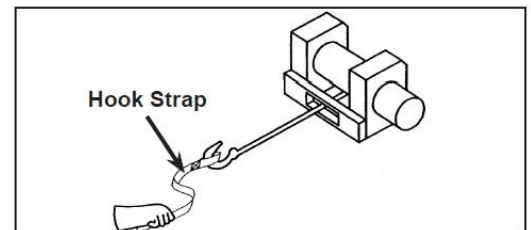

 **WARNING**

**NEVER** use a recovery strap when winching due to the excessive energy that can be released if the winch cable breaks. This can result in SEVERE INJURY or DEATH. See the Shock Loading section on page 15.

## WINCH OPERATION (continued)

- B. Never hook the winch cable back onto itself. This will damage the winch cable and may result in winch cable failure.

 **WARNING**

**ALWAYS** replace the winch cable at the first sign of damage to prevent SEVERE INJURY or DEATH in the event of a failure. For your safety, always replace KOLPIN winch parts (including the cable) with KOLPIN replacement parts available at your authorized KOLPIN dealer or the KOLPIN website.

- C. If possible, keep the winch cable aligned with the center line of the winching vehicle. This will help the spooling of the winch cable and reduce the load on the fairlead.
- D. If freeing a stuck vehicle by attaching to a tree, use an item such as a tow strap to avoid damaging the tree during winch operation. Sharp cables and chains can damage and even kill trees. Please remember to Tread Lightly® (treadlightly.org).

- E. Before operating the winch, be sure that the safety latch on the winch cable hook is fully seated when the load is attached.
- F. Never operate your winch with a damaged hook or latch. Always replace damaged parts before using the winch.

5. Never remove the hook strap from the hook.

6. Release the winch clutch and pull out the winch cable.

7. Pulling out as much cable as possible maximizes the winch's pulling capacity.

Always be sure that at least five full turns of winch cable are wrapped around the winch drum at all times. The friction provided by this wrapped cable allows the drum to pull on the winch cable and move the load.

8. Read and adhere to the following information for winch damping to ensure safe winch use.

- A. In order to absorb energy that could be released by a winch cable failure, always place a "damper" on the winch cable. A damper can be a heavy jacket, tarp, or other soft, dense object. A damper can absorb much of the energy released if a winch cable breaks when winching. Even a tree limb can help as a damper if no other items are available to you.
- B. Lay the damper on top of the mid-point of the winch cable length that is spooled out.
- C. On a long pull, it may be necessary to stop winching so that the damper can be repositioned to the new mid-point of the winch cable. Always release the tension on the winch cable before repositioning the damper.
- D. Avoid being directly in line with the winch cable whenever possible. Also, never permit others to stand near or in line with the winch cable during winch operation.

9. Never hook the winch cable back onto itself. This will damage the winch cable and may result in winch cable failure.

10. Never use straps, chains or other rigging items that are damaged or worn.

11. The **ONLY** time a winch-equipped vehicle should be moving when using the winch is when the vehicle itself is stuck. The winch equipped vehicle should **NEVER** be in motion to "shock" load the winch cable in an attempt to move a second stuck vehicle. See the **Shock Loading** section on page 14. For your safety, always follow these guidelines when winching a vehicle free:

- A. Release the winch clutch and spool out the necessary length of winch cable.
- B. Align the winch cable as close as possible to the winching vehicle's center line.
- C. Attach the winch cable hook to the anchor point or the stuck vehicle's frame following instructions in this manual.
- D. Re-engage the clutch on the winch.
- E. Slowly winch in the slack in the winch cable.
- F. Select the proper vehicle gear to propel the stuck vehicle in the direction of winching.
- G. Shift to the lowest gear available on the stuck vehicle.
- H. Slowly and carefully apply vehicle throttle and winch together to free the vehicle.
- I. Stop winching as soon as the stuck vehicle is able to propel itself without the help of the winch.
- J. Detach the winch cable hook.
- K. Rewind the winch cable evenly back onto the winch drum following the instructions in this manual.

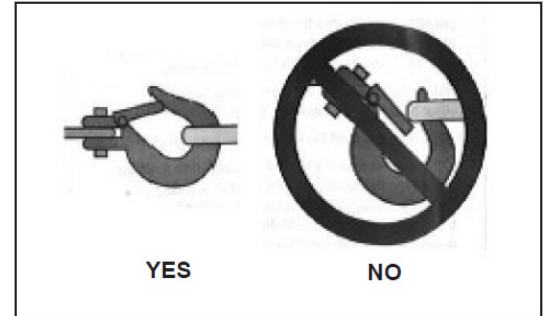

## WINCH OPERATION (continued)

12. Never attempt to winch another stuck vehicle by attaching the winch cable to a suspension component, brush guard, bumper or cargo rack. Vehicle damage may result. Instead, attach the winch to a strong portion of the vehicle frame or hitch.
13. Extensive winching will run down the battery on the winching vehicle. Let the winching vehicle's engine run while operating the winch to prevent the battery from running low if winching for long periods.
14. The winch motor may become hot during winch use. If you winch for more than 45 seconds, or if the winch stalls during operation, stop winching and permit the winch to cool down for 10 minutes before using it again.
15. After winching is complete, especially if winching at an angle, it may be necessary to re-distribute the winch cable across the winch drum. You will need an assistant to perform this task.
  - A. Release the clutch on the winch.
  - B. Feed out the winch cable that is unevenly bunched up in one area.
  - C. Re-engage the winch clutch.
  - D. Have an assistant pull the winch cable tightly with about 100 lbs. (45 kg) of tension using the hook strap.
  - E. Slowly winch the cable in while your assistant moves the end of the winch cable back and forth horizontally to evenly distribute the winch cable on the drum.
  - F. Doing this reduces the chances of the winch cable "wedging" itself between lower layers of winch cable.

## WINCH CABLE CARE

For your safety, always replace KOLPIN winch parts (including the cable) with KOLPIN replacement parts available at your authorized KOLPIN dealer or the KOLPIN website (Kolpin.com).

 **WARNING**

**NEVER** use a worn or damaged cable. Use of a worn or damaged cable could lead to sudden failure and SEVERE INJURY.

1. Always inspect your winch before each use. Inspect for worn or loose parts including mounting hardware. Never use the winch if any part needs repair or replacement.
2. Always inspect your winch cable before each use. Inspect for worn or kinked winch cable.
  - A. A kinked winch cable made of wire rope is shown at right. Even after being "straightened out," this cable has already been permanently and severely damaged. Promptly discontinue use of a winch cable in this condition.
  - B. A kinked winch cable made of wire rope that has been "straightened out" is shown at right. Even though it may look usable, the cable has been permanently and severely damaged. It can no longer transmit the load that it could prior to kinking. Promptly discontinue use of a winch cable in this condition.
  - C. A winch cable made of synthetic rope should be inspected for signs of fraying. Replace the cable if fraying is observed (shown at right). Promptly discontinue use of a winch cable in this condition.
  - D. Also replace the winch cable if there are fused or melted fibers. Such an area of the synthetic rope will be stiff and appear smooth or glazed. Promptly discontinue use of a winch cable in this condition.

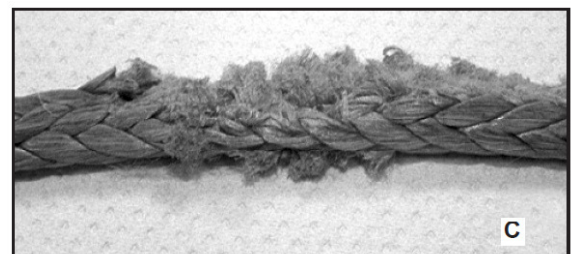
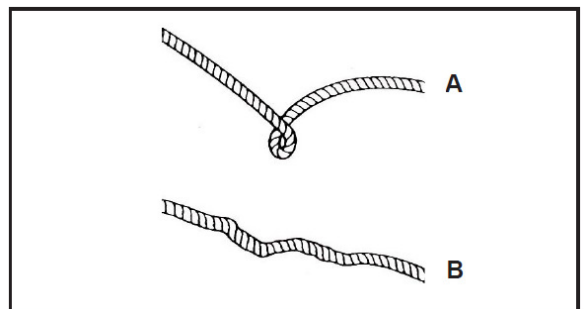

## SHOCK LOADING

 <b>WARNING</b>
<p><b>NEVER</b> shock load a winch cable. Your winch cable is very strong but it is NOT designed for dynamic, or “shock” loading. Shock loading may tension a winch cable beyond its strength and cause the cable to break. The end of a broken winch cable under such high loading can cause SEVERE INJURY or DEATH to you and other bystanders.</p>

*Winch cables are designed to NOT absorb energy. This is true of both wire-rope and synthetic-rope winch cables.*

1. Never attempt to “jerk” a load with the winch. For example, never take up slack in the winch cable by moving the winching vehicle in an attempt to move an object. This is a dangerous practice. It generates high winch cable loads that may exceed the strength of the cable. Even a slowly moving vehicle can create large shock loads in a winch cable.

 <b>WARNING</b>
<p><b>NEVER</b> use a broken winch cable. SEVERE INJURY or DEATH can result.</p>

2. Never quickly turn the winch ON and OFF repeatedly (“jogging”). This puts extra load on the winch, winch cable, and generates excessive heat from the motor. This is a form of shock loading.
3. Never tow a vehicle or other object with your winch. Towing an object with a winch produces shock loading of the cable even when towing at slow speeds. Towing from a winch also positions the towing force high on the vehicle. This can cause instability of the vehicle and possibly lead to an accident.
4. Never use recovery straps with your winch. Recovery straps are designed to stretch and can store energy. This stored energy in the recovery strap is released if a winch cable fails making the event even more hazardous. Similarly, never use elastic “bungee” cords for winching.
5. Never use the winch to tie down a vehicle to a trailer or other transportation vehicle. This type of use also causes shock loading that can cause damage to the winch, winch cable, or vehicles used.
6. ***Your winch cable is designed and tested to withstand the loads produced by the winch motor when operated from a stationary vehicle. Always remember that the winch and winch cable are NOT designed for shock loading.***

## WINCH MAINTENANCE AND SERVICE SAFETY

### **WARNING**

**ALWAYS** follow all winch instructions and warnings in this manual. Improper or lack of winch maintenance and service could lead to SEVERE INJURY or DEATH.

1. Always inspect your winch before each use. Inspect for worn or kinked winch cable. Also inspect for worn or loose parts including mounting hardware.
2. Permit your winch motor to cool down prior to servicing your winch.
3. Never work on your winch without first disconnecting the battery connections to prevent accidental activation of the winch
4. For your safety, always replace KOLPIN winch parts (including the cable) with KOLPIN replacement parts available at your authorized KOLPIN dealer or the KOLPIN website (Kolpin.com).
5. Some winch models use wire rope as the winch cable. Other winches use a specially designed synthetic rope as the winch cable.
6. Never replace a synthetic-rope winch cable with a consumer-grade polymer rope such as can be purchased in a hardware store. Although they may look similar, they are NOT alike. A polymer rope not designed for winch use will stretch and store excessive energy when winching.

### **WARNING**

**ALWAYS** be aware that failure of a stretched rope under winching conditions will release all of the stored energy. This will increase the chances of SEVERE INJURY or DEATH.

## LUBRICATION

All moving parts within the electric winch have been lubricated using high temperature grease at the factory. No internal lubrication is required. Never grease or oil the winch cable. This will cause the winch cable to collect debris that will shorten the life of the cable.

## CABLE ASSEMBLY REPLACEMENT

It is recommended that only KOLPIN supplied parts be used.

1. Move the clutch to the “free-spool” position.
2. Extend cable assembly to its full length. Note how the existing cable is connected to the inside of the drum.
3. Remove old cable assembly and attach new one.
4. Retract cable assembly onto drum being careful not to allow kinking.

### **NOTE**

For service or parts assistance, contact our help line at **1-877-956-5746**.

# PERFORMANCE SPECIFICATIONS

- Motor: 12V DC, permanent magnet type, heavy duty
  - 1.1 HP ..... 2500 lb. rated pull
  - 1.2 HP ..... 3500 lb. rated pull
  - 1.3 HP ..... 4500 lb. rated pull
- Motor duty cycle: Intermittent
- Gear reduction ratio ..... 166 : 1
- Brake: Mechanical
- Electric cable leads ..... 8 gauge (2500 lb. & 3500 lb.), 6 gauge (4500 lb.)
- Winch cable size:
  - 50' length x 3/16" diameter wire rope (3/16" diameter synthetic model) ..... 2500 lb. rated pull
  - 50' length x 7/32" diameter wire rope (3/16" diameter synthetic model) ..... 3500 lb. rated pull
  - 50' length x 7/32" diameter wire rope (1/4" diameter synthetic model) ..... 4500 lb. rated pull
- Drum size: 50mm diameter x 74mm length

## 2500 lb. Specifications:

Line Pull (lbs)	Line Speed (ft/min)	Motor (amps)
0	25	24
500	18	50
1500	15	118
2500	9	210

## 3500 lb. Specifications:

Line Pull (lbs)	Line Speed (ft/min)	Motor (amps)
0	23	24
500	17	56
1500	14	120
2500	9	220
3500	7	240

## 4500 lb. Specifications:

Line Pull (lbs)	Line Speed (ft/min)	Motor (amps)
0	23	29
500	17	60
1500	14	130
2500	9	225
3500	7	260
4500	5	310

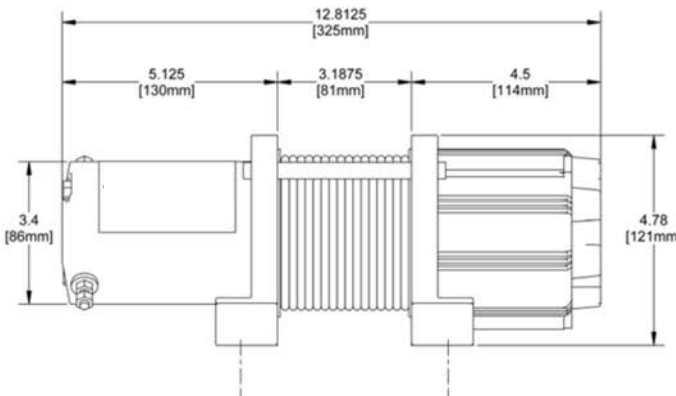

Winch Dimensions - Front View

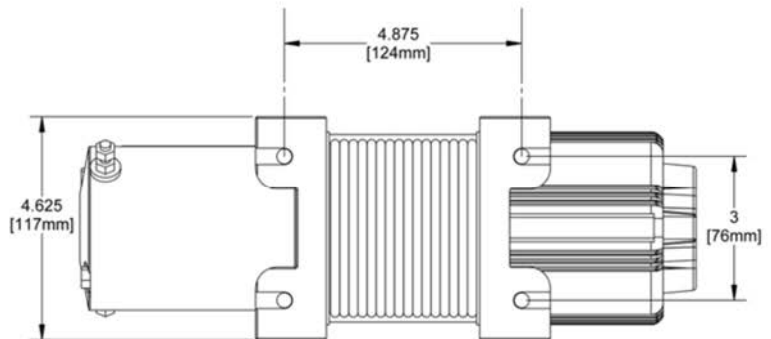

Winch Dimensions - Bottom View

**25-9250 Kit Contents (2500 lb) and Replacement Part Numbers:**

Item	Qty	Part Description	Replacement Part Number
1	1	Replacement Winch 2500#	25-9250R
2	1	Kolpin winch hook strap, orange	85071
3	1	Kolpin steel cable, 3/16" diameter x 50' length	85062
4	1	Rocker switch	85066
5	1	Contactora/solenoid	85068
6	1	Roller fairlead	85069
7	2	Lock washer, M4	-
8	2	Flat washer, M4	-
9	1	Scotch lock	-
10	6	Cable tie, 8"	-
11	2	Hex nut, M4	-
12	8	Flat washer, M8	-
13	4	Hex nut, M8 x 1.25	-
14	4	Lock washer, M8	-
15	6	Hex bolt, M8 x 1.25 x 25mm zinc plated	-
16	2	Hex bolt, M8 x 1.25 x 20mm zinc plated	-
17	6	Terminal cap	RPR0109
18	1	Clevis hook	RPR0108
19	1	Cable, red, 8-gauge, 36"	85089
20	1	Cable, black, 8-gauge, 36"	85089
21	1	Cable, yellow, 8-gauge, 96"	85090
22	1	Cable, blue, 8-gauge, 96"	85090
23	1	Universal Fairlead Mount Bracket	-
24	2	Pan screw, M4 x 30	-

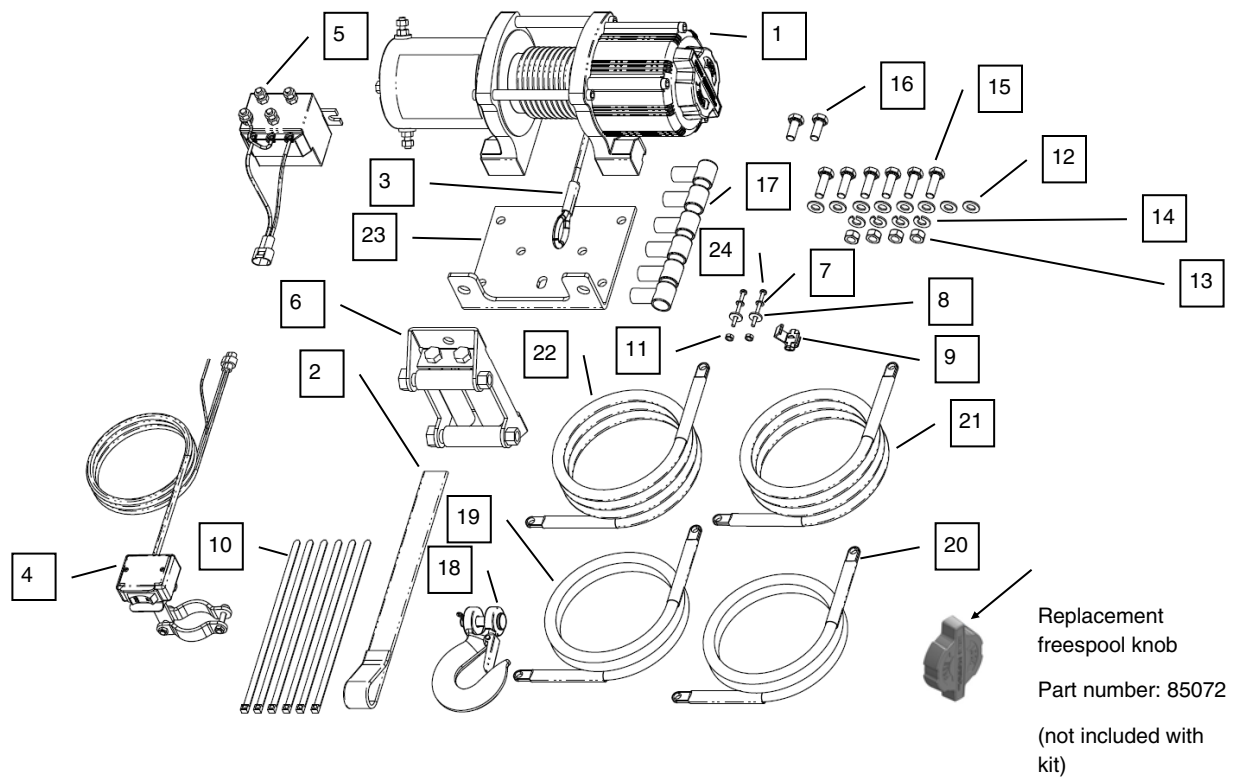



**25-9255 Kit Contents (2500 lb) and Replacement Part Numbers:**

Item	Qty	Part Description	Replacement Part Number
1	1	Replacement Winch 2500#	25-9250R
2	1	Kolpin winch hook strap, orange	85071
3	1	Kolpin synthetic rope, 1/4" diameter x 50' length	85064
4	1	Rocker switch	85066
5	1	Contactator/solenoid	85068
6	1	Roller fairlead	85069
7	2	Lock washer, M4	-
8	2	Flat washer, M4	-
9	1	Scotch lock	-
10	6	Cable tie, 8"	-
11	2	Hex nut, M4	-
12	8	Flat washer, M8	-
13	4	Hex nut, M8 x 1.25	-
14	4	Lock washer, M8	-
15	6	Hex bolt, M8 x 1.25 x 25mm zinc plated	-
16	2	Hex bolt, M8 x 1.25 x 20mm zinc plated	-
17	6	Terminal cap	RPR0109
18	1	Clevis hook	RPR0108
19	1	Cable, red, 8-gauge, 36"	85089
20	1	Cable, black, 8-gauge, 36"	85089
21	1	Cable, yellow, 8-gauge, 96"	85090
22	1	Cable, blue, 8-gauge, 96"	85090
23	1	Winch Stop	85080
24	1	Universal Fairlead Mount Bracket	-
25	2	Pan screw, M4 x 30	-

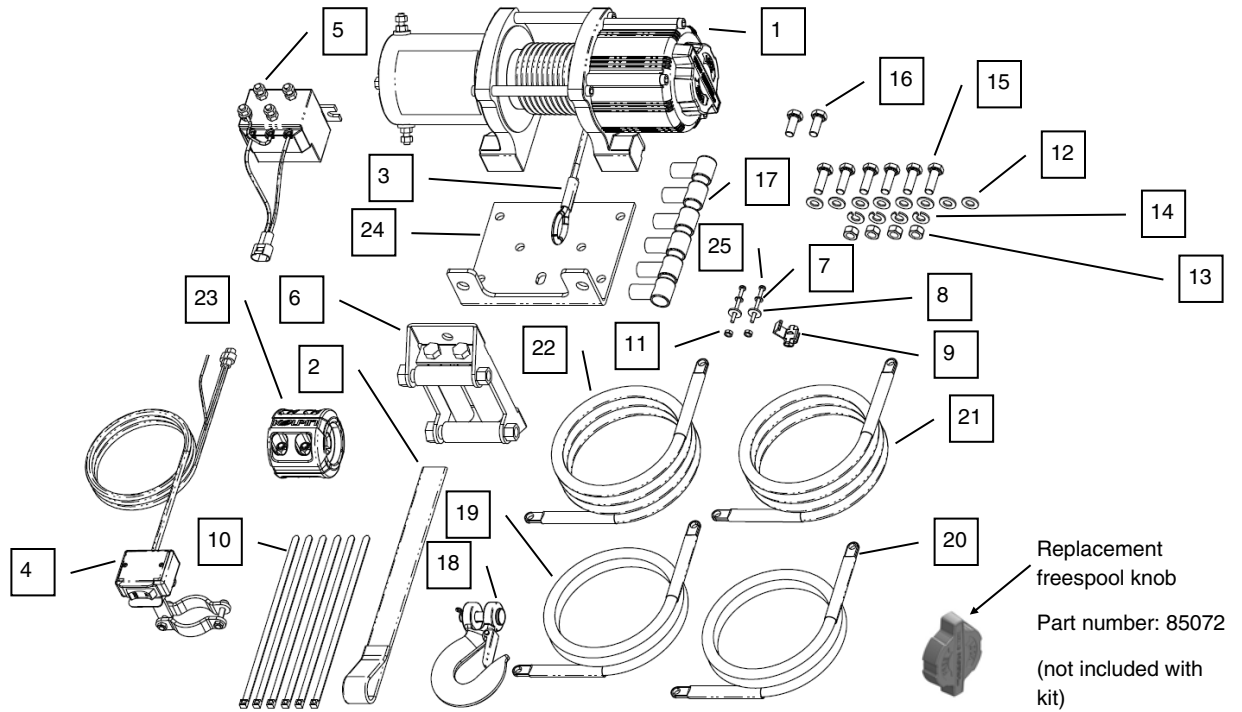



**25-9350 Kit Contents (3500 lb) and Replacement Part Numbers:**

Item	Qty	Part Description	Replacement Part Number
1	1	Replacement Winch 3500#	25-9350R
2	1	Kolpin winch hook strap, orange	85071
3	1	Kolpin steel cable, 7/32" diameter x 50' length	85063
4	1	Rocker switch	85066
5	1	Contactora/solenoid	85068
6	1	Roller fairlead	85069
7	2	Lock washer, M4	-
8	2	Flat washer, M4	-
9	1	Scotch lock	-
10	6	Cable tie, 8"	-
11	2	Hex nut, M4	-
12	8	Flat washer, M8	-
13	4	Hex nut, M8 x 1.25	-
14	4	Lock washer, M8	-
15	6	Hex bolt, M8 x 1.25 x 25mm zinc plated	-
16	2	Hex bolt, M8 x 1.25 x 20mm zinc plated	-
17	6	Terminal cap	RPR0109
18	1	Clevis hook	RPR0108
19	1	Cable, red, 8-gauge, 36"	85089
20	1	Cable, black, 8-gauge, 36"	85089
21	1	Cable, yellow, 8-gauge, 96"	85090
22	1	Cable, blue, 8-gauge, 96"	85090
23	1	Corded Remote Switch	85067
24	1	Universal Fairlead Mount Bracket	-
25	2	Pan screw, M4 x 30	-

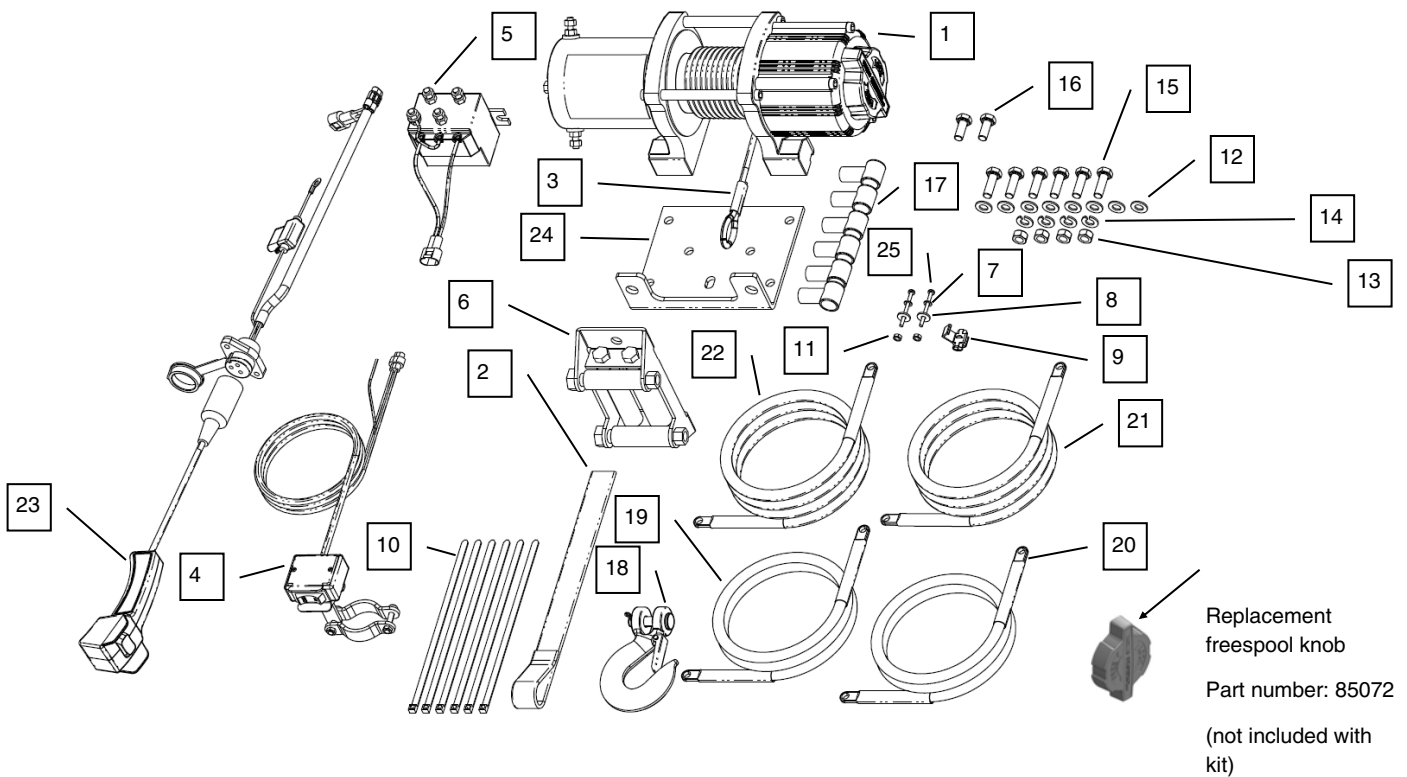

**25-9355 Kit Contents (3500 lb) and Replacement Part Numbers:**

Item	Qty	Part Description	Replacement Part Number
1	1	Replacement Winch 3500#	25-9350R
2	1	Kolpin winch hook strap, orange	85071
3	1	Kolpin synthetic rope, 1/4" diameter x 50' length	85064
4	1	Rocker switch	85066
5	1	Contactor/solenoid	85068
6	1	Roller fairlead	85069
7	2	Lock washer, M4	-
8	2	Flat washer, M4	-
9	1	Scotch lock	-
10	6	Cable tie, 8"	-
11	2	Hex nut, M4	-
12	8	Flat washer, M8	-
13	4	Hex nut, M8 x 1.25	-
14	4	Lock washer, M8	-
15	6	Hex bolt, M8 x 1.25 x 25mm zinc plated	-
16	2	Hex bolt, M8 x 1.25 x 20mm zinc plated	-
17	6	Terminal cap	RPR0109
18	1	Clevis hook	RPR0108
19	1	Cable, red, 8-gauge, 36"	85089
20	1	Cable, black, 8-gauge, 36"	85089
21	1	Cable, yellow, 8-gauge, 96"	85090
22	1	Cable, blue, 8-gauge, 96"	85090
23	1	Winch Stop	85080
24	1	Corded Remote Switch	85067
25	1	Universal Fairlead Mount Bracket	-
26	2	Pan screw, M4 x 30	-

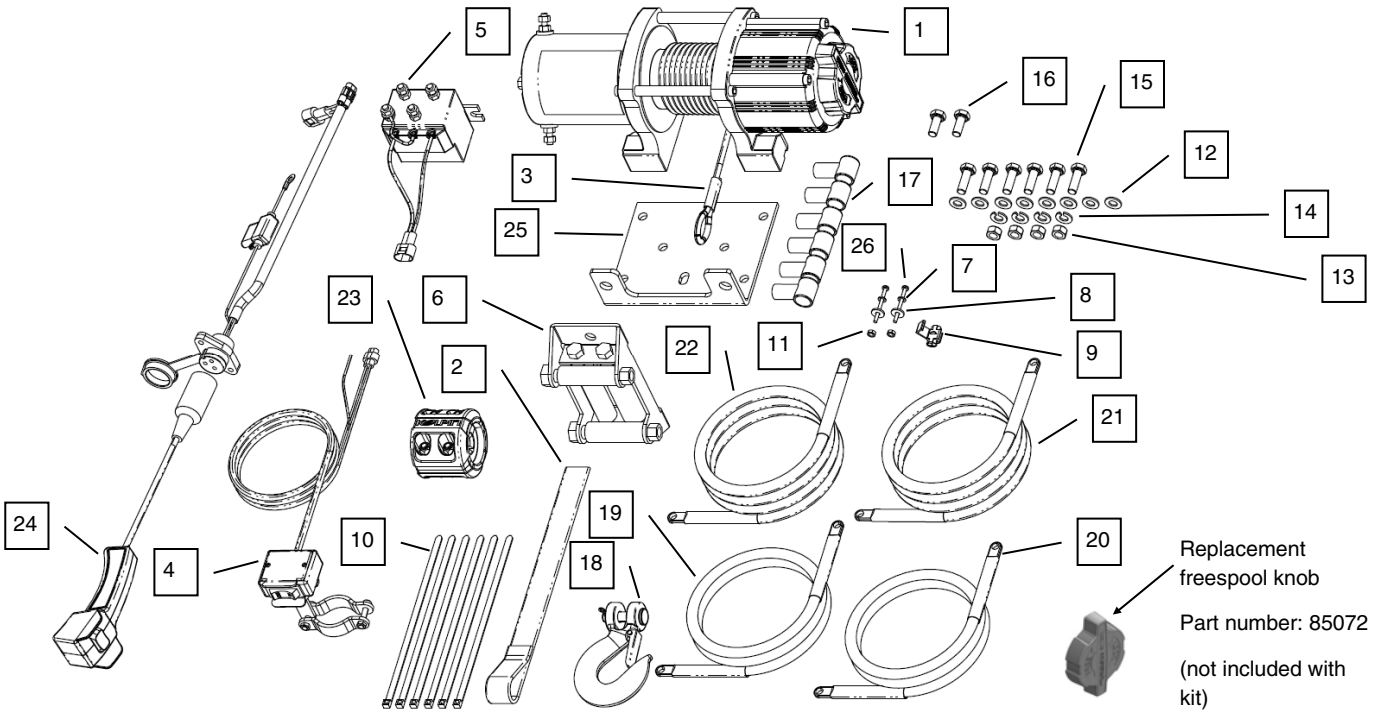

**25-9450 Kit Contents (4500 lb) and Replacement Part Numbers:**

Item	Qty	Part Description	Replacement Part Number
1	1	Replacement Winch 4500#	25-9450R
2	1	Kolpin winch hook strap, orange	85071
3	1	Kolpin steel cable, 7/32" diameter x 50' length	85063
4	1	Rocker switch	85066
5	1	Contactora/solenoid	85068
6	1	Roller fairlead	85069
7	2	Lock washer, M4	-
8	2	Flat washer, M4	-
9	1	Scotch lock	-
10	6	Cable tie, 8"	-
11	2	Hex nut, M4	-
12	8	Flat washer, M8	-
13	4	Hex nut, M8 x 1.25	-
14	4	Lock washer, M8	-
15	6	Hex bolt, M8 x 1.25 x 25mm zinc plated	-
16	2	Hex bolt, M8 x 1.25 x 20mm zinc plated	-
17	6	Terminal cap	RPR0109
18	1	Clevis hook	RPR0108
19	1	Cable, red, 6-gauge, 36"	85089
20	1	Cable, black, 6-gauge, 36"	85089
21	1	Cable, yellow, 6-gauge, 96"	85090
22	1	Cable, blue, 6-gauge, 96"	85090
23	1	Corded Remote Switch	85067
24	1	Dash Mount Bracket	85082
25	1	Universal Fairlead Mount Bracket	-
26	2	Pan screw, M4 x 30	-

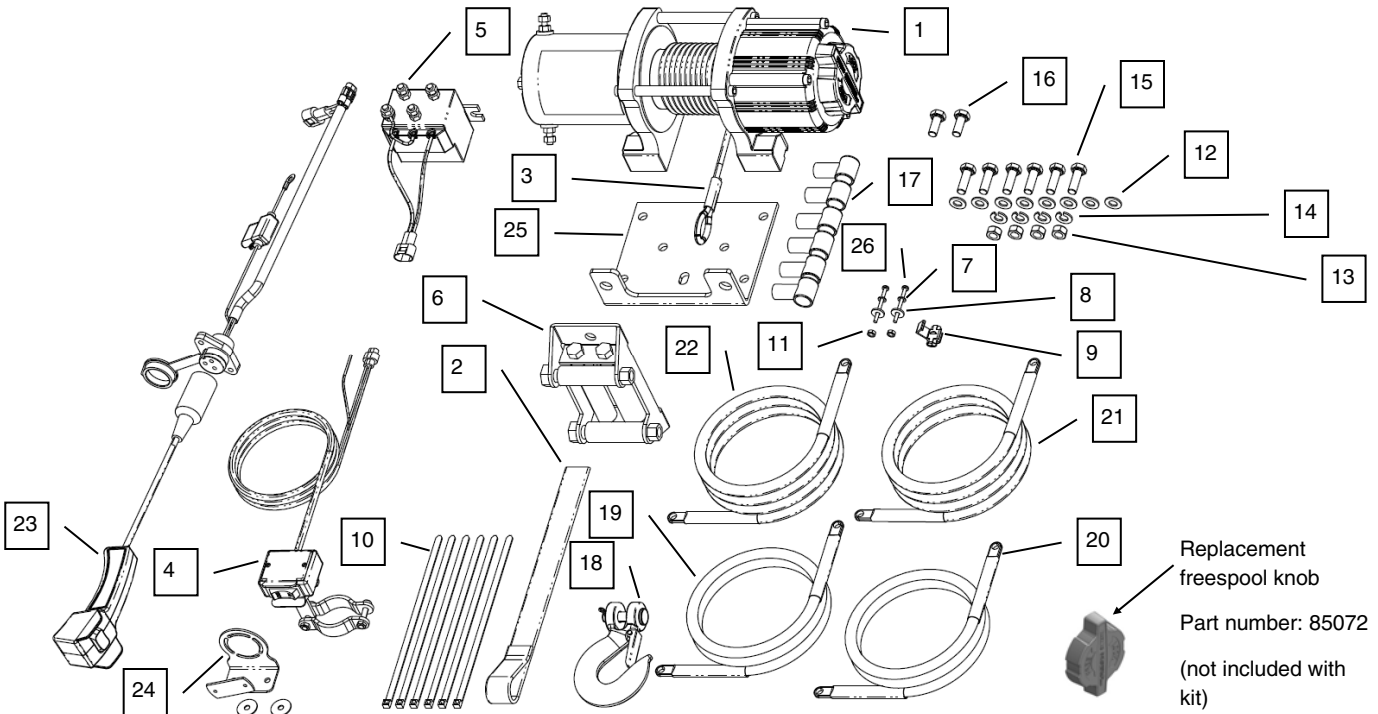

**25-9455 Kit Contents (4500 lb) and Replacement Part Numbers:**

Item	Qty	Part Description	Replacement Part Number
1	1	Replacement Winch 4500#	25-9450R
2	1	Kolpin winch hook strap, orange	85071
3	1	Kolpin synthetic rope, 1/4" diameter x 50' length	85064
4	1	Rocker switch	85066
5	1	Contactora/solenoid	85068
6	1	Roller fairlead	85069
7	2	Lock washer, M4	-
8	2	Flat washer, M4	-
9	1	Scotch lock	-
10	6	Cable tie, 8"	-
11	2	Hex nut, M4	-
12	8	Flat washer, M8	-
13	4	Hex nut, M8 x 1.25	-
14	4	Lock washer, M8	-
15	6	Hex bolt, M8 x 1.25 x 25mm zinc plated	-
16	2	Hex bolt, M8 x 1.25 x 20mm zinc plated	-
17	6	Terminal cap	RPR0109
18	1	Clevis hook	RPR0108
19	1	Cable, red, 6-gauge, 36"	85089
20	1	Cable, black, 6-gauge, 36"	85089
21	1	Cable, yellow, 6-gauge, 96"	85090
22	1	Cable, blue, 6-gauge, 96"	85090
23	1	Winch Stop	85080
24	1	Corded Remote Switch	85067
25	1	Dash Mount Bracket	85082
26	1	Universal Fairlead Mount Bracket	-
27	2	Pan screw, M4 x 30	-

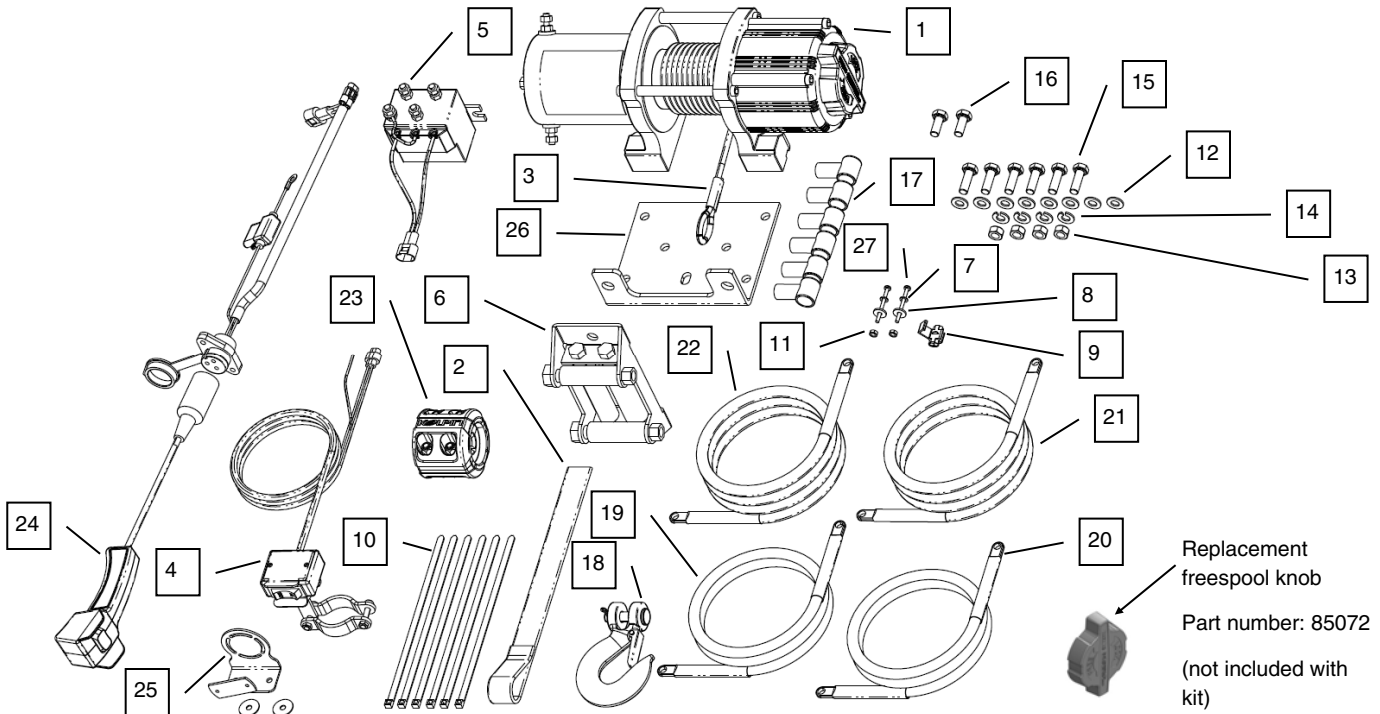

## TROUBLESHOOTING

Problem	Cause	Solution
Motor does not turn	Switch assembly not connected properly	Insert switch assembly all the way into the connector.
	Loose battery cable connections	Tighten nuts on all cable connections.
	Contactor malfunctioning	Tap contactor to loosen contacts. Apply 12 volts to coil terminals directly. A clicking indicates proper activation.
	Defective switch assembly	Replace switch assembly.
	Defective motor	Check for voltage at armature port with switch pressed. If voltage is present, replace winch assembly.
	Nested and bounded cable within winch assembly	Move freespool knob to the "free spool" position. Manually pull cable out of winch until end is met and then re-spool cable back into winch.
	Water has entered motor	Allow to drain and dry. Run in short bursts without load until completely dry.
Motor runs but cable drum does not turn	Clutch (freespool knob) not engaged	Move freespool knob to the "locked spool" position. If problem persists, a qualified technician needs to check and repair.
Motor runs slowly or without normal power	Insufficient current or voltage	The battery is weak, recharge. Run winch with vehicle motor running (battery should have a strong charge).
	Loose or corroded battery cable connections	Clean, tighten, or replace.
Motor overheating	Winch running time too long	Allow winch to cool down periodically.
Motor runs in one direction only	Defective or stuck contactor	Tap contactor to loosen contacts.
		Repair or replace contactor.
	Defective switch assembly	Replace switch assembly.
	Defective brake assembly	Replace winch assembly.

***Note: If any hardware is missing, do not return to the store. Call us to help, Toll Free 1-877-956-5746.***

### NOTE

For further technical support, contact our help line at **1-877-956-5746**.



## **Five Year Mechanical Limited Warranty and Three Year Electrical Limited Warranty**

For the period of five (5) years from the purchase date, Kolpin will replace for the original purchaser, free of charge, any mechanical part or mechanical parts found upon examination by Kolpin to be defective in material, workmanship, or both. For the period of three (3) years from the purchase date, Kolpin will replace for the original purchaser, free of charge, any electrical part or electrical parts found upon examination by Kolpin to be defective in material, workmanship, or both.

All transportation costs incurred submitting product to Kolpin for warranty consideration must be borne by the purchaser. If Kolpin determines that the product must be returned to the factory for credit, please call 1-877-956-5746 for a Return Merchandise Authorization (RMA) number and shipping instructions.

This warranty does not apply to parts that have been damaged by accident, alteration, abuse, improper maintenance, normal wear, or other causes beyond the manufacturer's control. In order to protect you and your ATV, certain parts of the winch/plow system and/or hardware are designed to fail when the equipment is over-stressed. Parts that are lost due to loosening and improper maintenance are not covered under warranty. This warranty does not cover removal or reinstallation labor fees of the winch/plow system and related components.

Peripheral products such as engines, electric motors, and actuators may carry an original manufacturer's warranty. Most hardware is general in nature and is easily obtained locally. Be sure to replace with minimum metric class 8.8 specification.

**Kolpin Outdoors, Inc.**

**Telephone: (763)-478-5800**

**Toll Free: (877)-956-5746**

**Fax Number: (800)-245-7569**

**[www.kolpin.com](http://www.kolpin.com)**

**Email: [customerservice@kolpin.com](mailto:customerservice@kolpin.com)**

# **KOLPIN<sup>®</sup>** **OUTDOORS**

**2500 lb / 3500 lb / 4500 lb**

## **ATV / UTV WINCH KIT**

**P/Ns: 25-9250, 25-9255, 25-9350, 25-9355, 25-9450, 25-9455**

**OWNER'S / OPERATING INSTRUCTIONS / SPARE PARTS**

Application

WINCH MOUNT NO. 25-XXXX, OEM VEHICLE WINCH MOUNTS

Before you begin, please read these instructions and check to be sure all parts and tools are accounted for. The following instructions contain details required to operate, install and service the contents of this kit. Save these instructions. Important safety instructions are included in this manual.



# **TABLE OF CONTENTS**

## **Introduction**

Introduction .....	3
Guidebook Conventions .....	3

## **Controls and Features** .....

4

Winch .....	4
-------------	---

## **Assembly** .....

5

Mounting .....	5
----------------	---

Mounting the winch .....	5
--------------------------	---

Mounting the handlebar switch .....	6
-------------------------------------	---

Mounting the contactor/solenoid .....	6
---------------------------------------	---

Mounting the remote switch (optional) .....	7
---	---

Wiring the winch .....	7
------------------------	---

Winch Wiring diagram .....	8
----------------------------	---

Corded Remote and Rocker Switch Wiring Diagram .....	9
--	---

## **ATV/UTV Winch User Guide** .....

10

Winch Safety Precautions .....	10-11
--------------------------------	-------

Winch Operation .....	12-14
-----------------------	-------

Wire Cable Care .....	14
-----------------------	----

Shock loading .....	15
---------------------	----

## **Winch Maintenance and Service Safety** .....

16

Lubrication .....	16
-------------------	----

Cable Assembly Replacement .....	16
----------------------------------	----

## **Specifications** .....

17

Performance Specifications .....	17
----------------------------------	----

Parts Kit Diagrams and replacement part numbers .....	18-23
---	-------

## **Troubleshooting** .....

24

## **Warranty** .....

25



## INTRODUCTION

Congratulations on your purchase of a Kolpin winch! The Kolpin winch works great for vehicle recovery and plow lift applications. With proper use and maintenance, this winch will bring many years of satisfying service.

Every effort has been made to ensure the accuracy and completeness of the information in this manual. We reserve the right to change, alter and/or improve the product and this document at any time without prior notice.

Record the part numbers, date of purchase and place of purchase for future reference. Please have this information available when ordering parts and when making technical or warranty inquiries.

<b>Kolpin Outdoors Support</b>
1-877-956-5746
<b>Part Number</b>
<b>Date of Purchase</b>
<b>Purchase Location</b>

## GUIDEBOOK CONVENTIONS

This manual uses the following symbols to help differentiate between different kinds of information. The safety symbol is used with a signal word to alert you to potential hazards in operating and owning power equipment. Follow all safety messages to avoid or reduce the risk of serious injury or death. Each message has a specific purpose. **PLEASE WORK SAFELY!**

 <b>WARNING</b>
<b>WARNING</b> indicates a potentially hazardous situation that, if not avoided, could result in death or serious injury.

<b>NOTICE</b>
<b>NOTICE</b> indicates a potentially hazardous situation which, if not avoided, may result in property damage.

 <b>CAUTION</b>
<b>CAUTION</b> indicates a potentially hazardous situation that, if not avoided, may result in minor or moderate injury.

<b>NOTE</b>
If you have questions regarding your winch, we can help. Please call our help line at <b>1-877-956-5746</b> .

# CONTROLS AND FEATURES

Read this owner's manual before operating your winch. Familiarize yourself with the location and function of the controls and features. Save this manual for future reference. Some features may not exist on all models, but can be ordered as options, please contact technical services at **1-877-956-5746**.

## WINCH

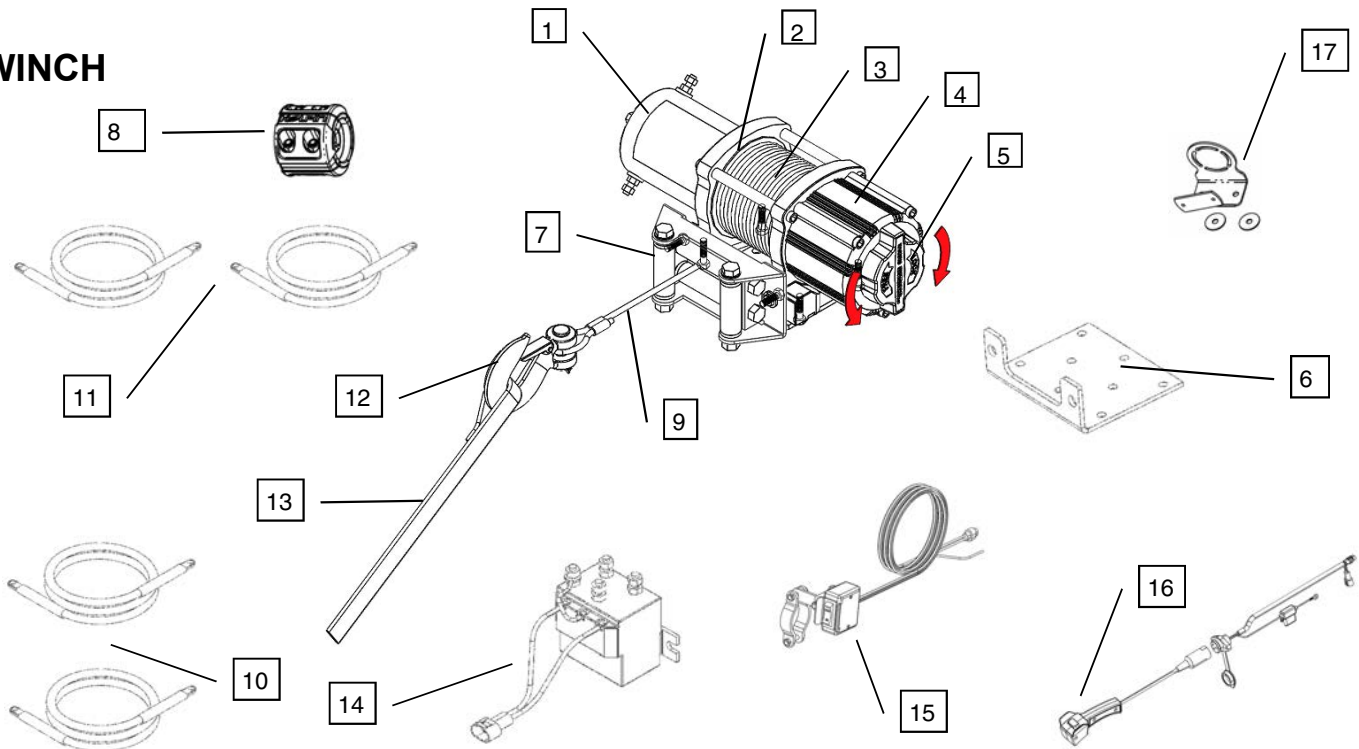

- (1) **Motor:** 12V DC motor provides power to the planetary gear mechanism.
- (2) **Braking System:** Braking action is automatically applied to the winch drum when the winch motor is stopped and there is a load on the winch cable.
- (3) **Winch Drum:** The winch drum is the cylinder on which the wire rope is stored. It can feed or wind the rope depending on the remote winch switch signal.
- (4) **Planetary Gear System:** The reduction gears convert the winch motor power into extreme pulling forces. This system allows high torque while maintaining compact size and light weight.
- (5) **Free Spooling Clutch:** The clutch allows the operator to manually disengage “Out” the spooling drum from the gear train, free spool. Engaging the clutch “In” locks the winch into the gear system.
- (6) **Mount Assembly:** Flatbed mounting channel.
- (7) **Roller Fairlead:** When using the winch at an angle, the roller fairlead acts to guide the wire rope onto the drum and minimizes damage to the wire rope from abrasion on the winch mount or bumper.
- (8) **Rubber Winch Stop:** Increases life of cables, ropes and fairleads. Quiets hook rattling noise.
- (9) **Rope:** Galvanized steel aircraft cable or synthetic rope designed specifically for winch load capacities.
- (10) **Winch Connection Cables:** Used to connect the contactor to the winch motor.
- (11) **Battery Connection Cables:** Used to connect the battery to the contactor.
- (12) **Clevis Hook:** Provides a means for connecting the looped ends of cables to an anchor.
- (13) **Strap:** Used to assist cable feed.
- (14) **Contactor/solenoid:** Power from the vehicle battery flows through the weather sealed contactor/solenoid switch before being directed to the winch motor.
- (15) **Rocker Switch:** Rocker switch with handlebar mount for powering the rope in or out of your winch drum.
- (16) **Corded Remote Switch:** Corded remote switch allows the operator to stand clear during the winching process.
- (17) **Dash Mount Bracket:** Bracket allows the handlebar rocker switch to be installed onto a dash surface.

# ASSEMBLY

The winch kit comes mostly assembled from the factory. Some pre-assembly of the kit is required for installation into vehicles.

## BEFORE YOU BEGIN:

- Your Kolpin accessory is designed for a universe fit for most vehicles.
- Please read and understand all instructions.
- Verify all parts and tools are accounted for.
- To ensure a satisfactory installation, follow all steps correctly and in the sequence described.
- To facilitate installation, make sure that your vehicle is clean and free of debris.
- All directions referring to right and left are when the rider is sitting on the machine.

## TOOLS REQUIRED:

- Basic metric wrench set
- Basic metric socket set
- Pliers
- Philips screwdriver

## MOUNTING THE WINCH

- If using a winch mounting kit, refer to the kit's manual for specific installation instructions. *See Kolpin.com for a full assortment of custom winch mounts for ATV/UTVs.*
- Mount the winch to the mount plate (not included) as shown below. Rotate the lock knob to the free spool position and feed the winch cable through the rollers of the roller fairlead.
- Mount the roller fairlead plate and attach the hook clevis and nylon pull strap. Rotate the lock knob back to the lock position.

**! WARNING**  
ALWAYS use supplied hook strap.

**NOTICE**  
ALWAYS ensure that the 3 major sections (motor, drum, gear housing) are properly aligned if utilizing a mounting plate. Proper alignment of the winch will allow for even distribution of the full rated load.

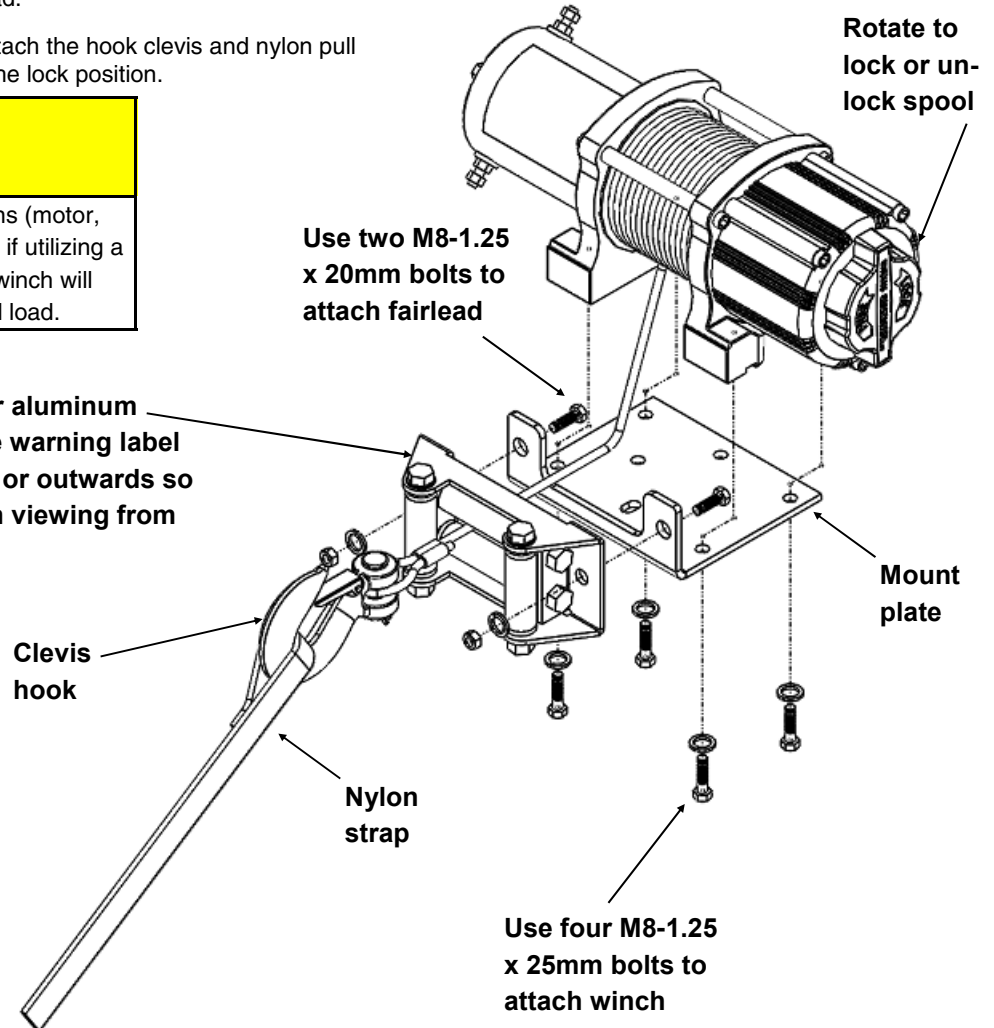

**Note: If any hardware is missing, do not return to the store. Call us to help, Toll Free 1-877-956-5746.**

## MOUNTING THE HANDLEBAR SWITCH

- Install the rocker switch to the handlebar using the hardware included in this kit as shown below.
- It is recommended that the switch be installed on the left handlebar. Exact position may vary depending on vehicle.
- Use a piece of electrical tape (not provided) around the handlebar to help prevent rotation of the switch bracket mount.
- Tighten the rocker switch in place. DO NOT overtighten or tighten/clamp over any hose, wiring or cables.
- Once the rocker switch is mounted, the wires can be routed to the contactor/solenoid location.
- Make sure the handlebars have full range of motion, vehicle switches/brakes/throttle can move freely, and then secure the rocker switch's cable with the supplied cable ties.
- Using the provided wire splice, splice the end of the red 20ga wire to a key controlled, fused, accessory circuit (power point) of the ATV/UTV. The wire should only have power when the key is in the "ON" position.

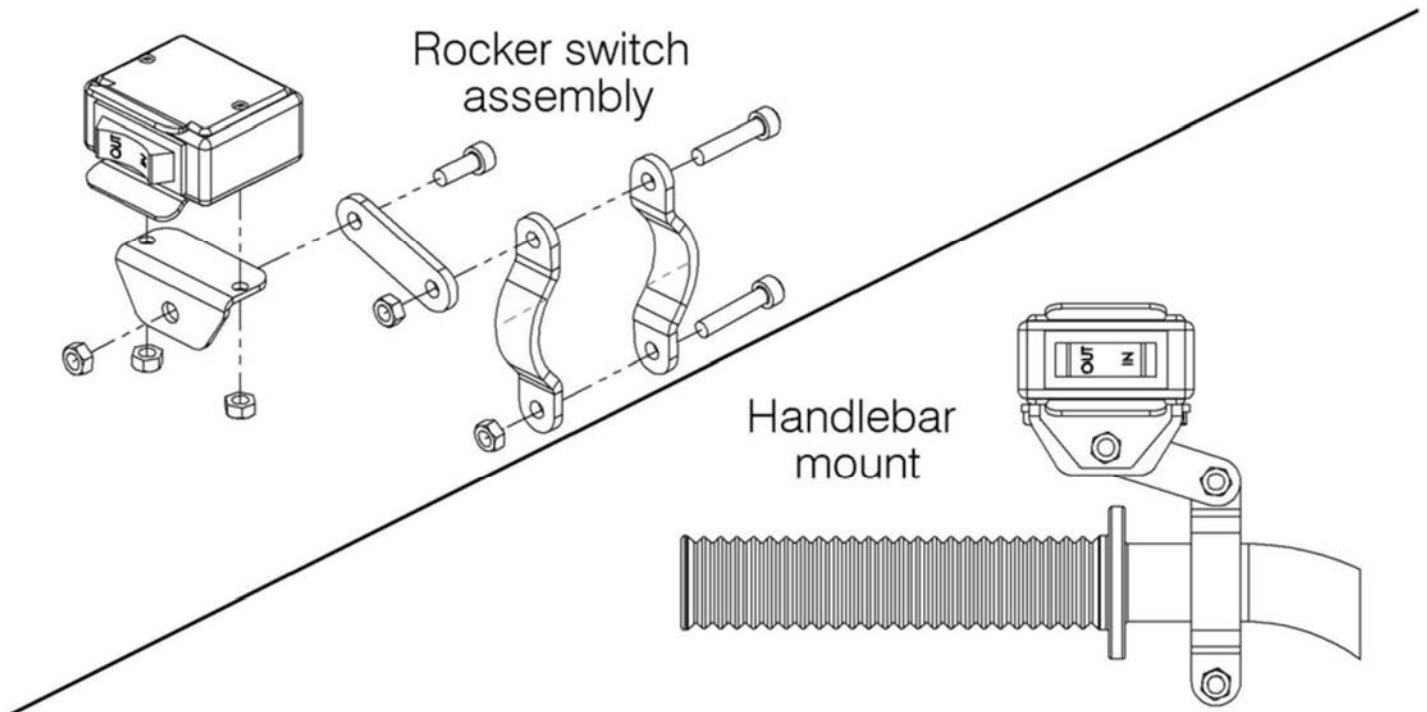

## MOUNTING THE CONTACTOR/SOLENOID

- The contactor/solenoid is a primary safety feature in the winch system. It disconnects the winch from its power source when the vehicle is not in use. The contactor/solenoid must be correctly installed to work properly.
- Find a location for the contactor/solenoid. It is recommended that the contactor/solenoid be mounted close to the battery in a clean, dry location. The exact location of the contactor/solenoid will vary depending on the vehicle. Make sure the location chosen allows for sufficient clearance from all metal components such as frame tubes. DO NOT place tools or other items in a position that might come in contact with the contactor/solenoid posts.
- Drill mounting holes if required. Secure the contactor/solenoid using the provided hardware.
- Once a location is found for the contactor/solenoid, DO NOT install the unit until all wiring is completed (see wiring section). Pre-fit all wiring to confirm its long enough to reach the battery and the winch contact locations.

**! WARNING**

**NEVER** short battery terminals with metal objects. Be aware terminals in contact with metal will cause a direct short, possibly causing contactor/ solenoid

## MOUNTING THE REMOTE SWITCH

### (optional on some models)

- Determine the mounting location for the remote socket. Exact position may vary depending on vehicle. Drill three holes and install to vehicle dash panel or body panel.
- Route the wire harness to where the contactor/solenoid will be mounted. Secure the socket's cable with the supplied cable ties.
- Using the provided wire splice, splice the end of the red 20ga wire to a key controlled, accessory circuit (power-point) of the ATV/UTV or use the provided 20ga wire eyelet terminal connector to connect to a vehicle terminal strip post. The wire should only have power when the key is in the "ON" position.
- **NOTE: If installing both switches (handlebar rocker and corded remote), both 20ga red wires must be connected together with the provided plug connectors or spliced to a key-controlled accessory circuit of the ATV/UTV as described in the above step.**

## NOTICE

**ALWAYS** make sure to splice into keyed accessory wire that has power when key is turned on. You may need to use a test light to locate a suitable wire.

## WIRING THE WINCH

- Install the wiring using the diagram on the next page.
- Slip terminal boots on yellow and blue cable ends. Connect the yellow and blue cables to the color-matched motor terminals on the winch. Tighten the terminal nuts on the motor. **DO NOT** overtighten. Seat boots over terminal. Route the other ends to the contactor/solenoid location.
- Connect the yellow and blue cables to the contactor/solenoid (yellow to yellow and blue to blue). **DO NOT** tighten nuts or seat boots at this time.
- Slip terminal boots on the ring terminal ends of the black and red cables. Connect the black and red cables to the contactor/solenoid (red to red and black to black). **DO NOT** tighten nuts or seat boots at this time. Route red and black cables to battery. **DO NOT** connect cables to battery at this time.
- **Mount the contactor to the location planned in the previous steps with provided hardware. Tighten the contactor/solenoid mounting fasteners. DO NOT overtighten.**
- Adjust cables to facilitate orderly and straight routing of the cables from the contactor/solenoid. Avoid kinks or sharp bends in the cables. Avoid crossing cables over each other for at least the first 6" of cable starting from the contactor/solenoid post. Tighten the contactor/solenoid terminal nuts. **DO NOT** over tighten. Seat terminal boots over ring terminals and posts.
- Connect the rocker switch to the contactor/solenoid using the provided plug. Splice the end of the red wire on the rocker switch, to a vehicle accessory circuit controlled by ignition controlled power source (keyed). The wire should only have power when the key is in the "ON" position.
- Carefully inspect battery and winch electrical cable routing to ensure it is neat and tidy. Secure electrical cables and wiring harnesses with provided cable ties. Cable ties should be snug, but not cutting into wire insulation. Use electrical tape, pieces of rubber hose or electrical conduit to protect electrical cables and wire harnesses where needed to avoid electrical cable insulation wear or abrasion.
- Connect the red lead to the positive (+) terminal of the vehicle's 12 volt battery first. Connect the black lead to the negative (-) terminal of the vehicle's 12 volt battery second. Install protective boots as appropriate to protect connection. Tighten battery terminal fasteners as directed in the vehicle service manual to the proper torque specification.
- Check for proper drum rotation. Pull and turn the clutch knob to the "free spool" position. Pull out some cable from the drum, and then turn the clutch knob to the "locked spool" position to engage the gears. Press the cable out button on the rocker switch. If the drum is turning and releasing more cable, your connections are accurate. If the drum is turning and collecting more cable, then reverse the leads on the motor. Repeat and check rotation.
- With some applications, the motor terminal posts may need to be rotated to avoid interference with other components.

## CAUTION

**NEVER** route electrical cables across any sharp edges, through and /or near moving parts, or near parts that may become hot.

## CAUTION

**ALWAYS** leave some slack for electrical cable movement. Battery cables should **NOT** be drawn taut.

# WINCH WIRING DIAGRAM

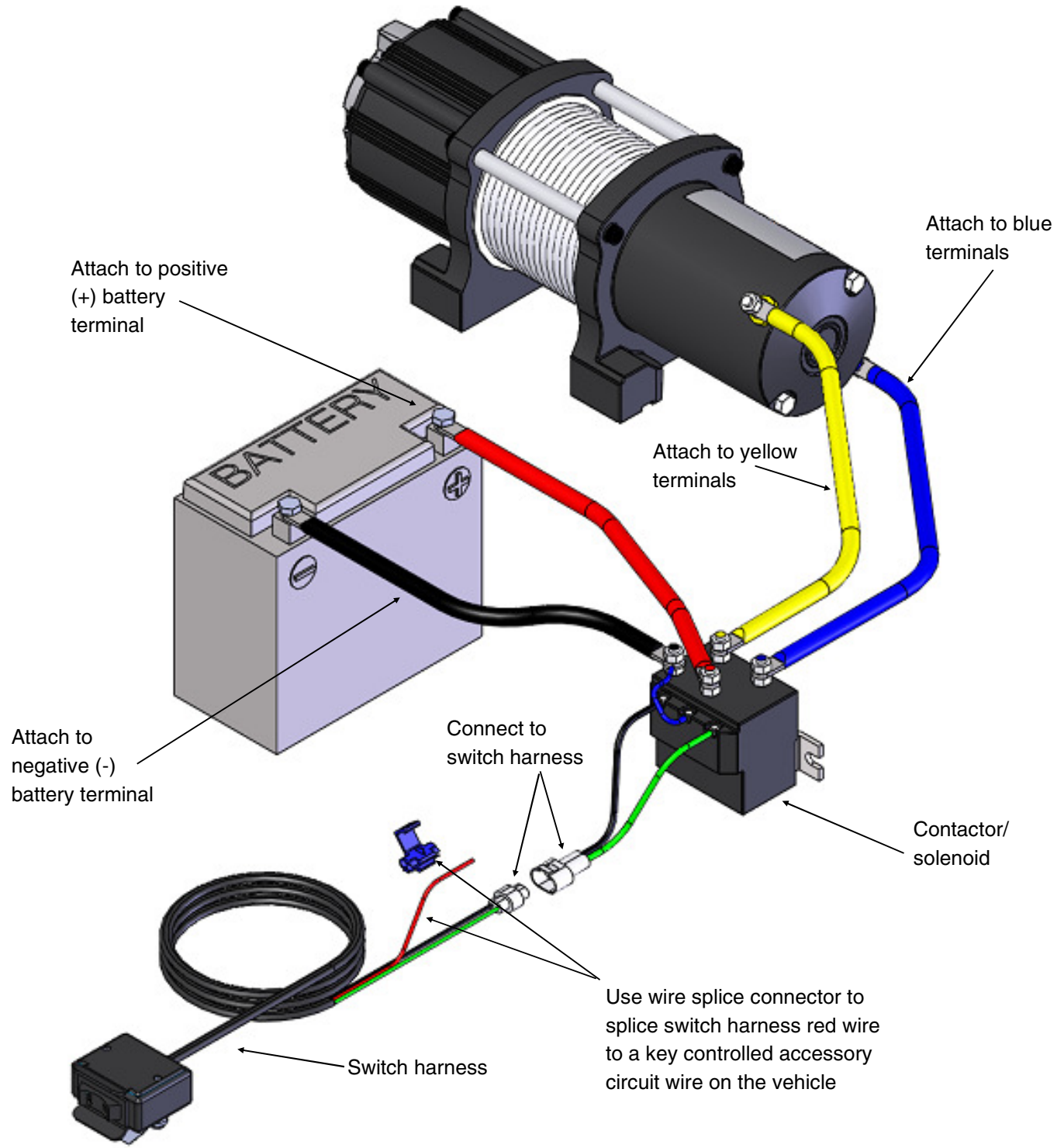



# CORDED REMOTE AND ROCKER SWITCH WIRING DIAGRAM

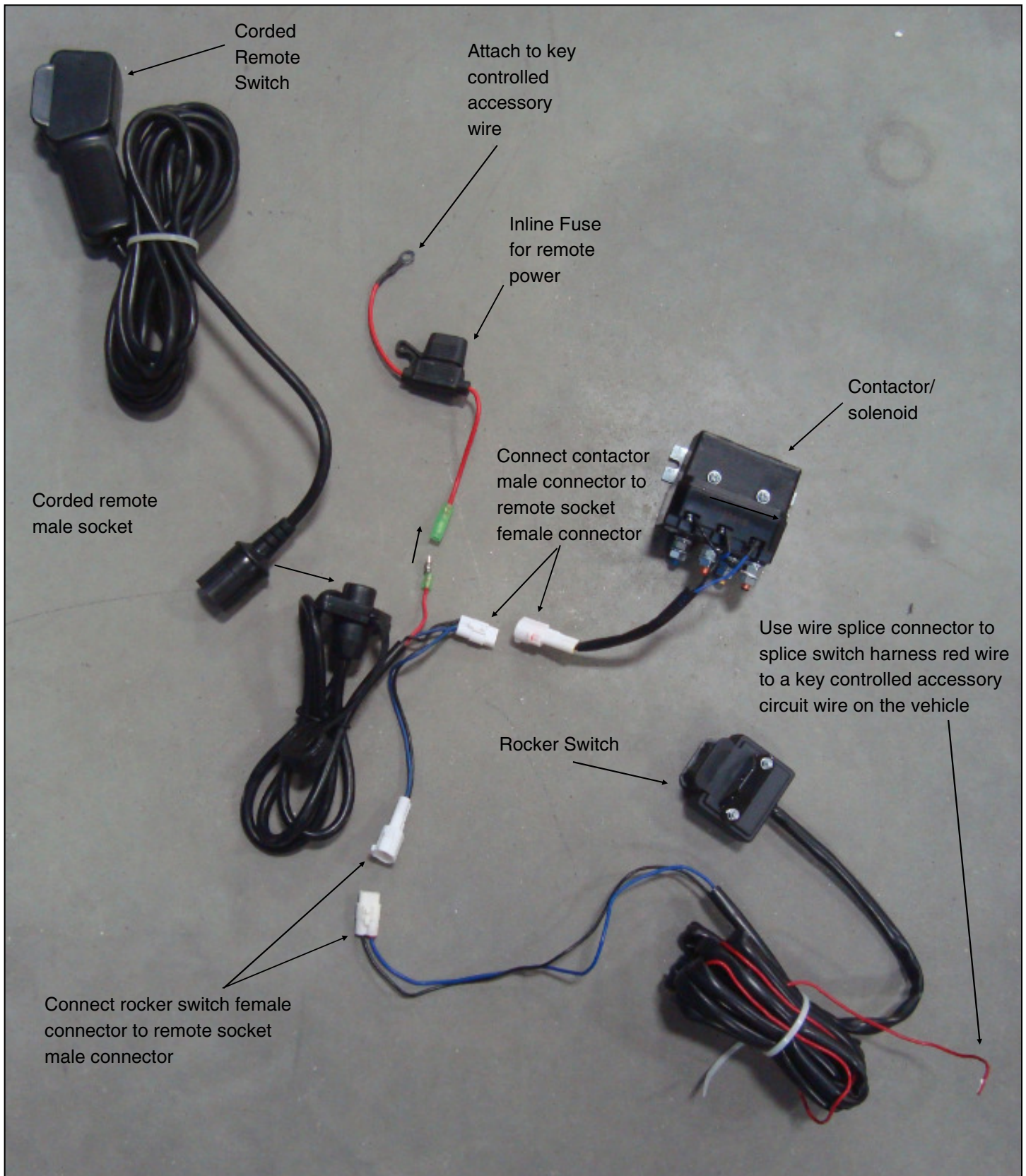



# ATV/UTV WINCH USER GUIDE

Before you begin using your winch, read and understand the guide. Please retain this guide for future reference.

These safety warnings and instructions apply if you choose to add an accessory winch to your vehicle.



Your winch may have a cable made of either wire rope or specially designed synthetic rope. The term “winch cable” will be used for either unless noted otherwise.

## WINCH SAFETY PRECAUTIONS

1. Read all sections of this manual.
2. Never use alcohol or drugs before or while operating the winch.
3. Never allow children under 16 years of age to operate the winch.
4. Always wear eye protection and heavy gloves when operating the winch.
5. Always keep body, hair, clothing and jewelry clear of the winch cable, fairlead and hook when operating winch.
6. Never attempt to “jerk” a load attached to the winch with a moving vehicle. See the **Shock Loading** section on page 15.
7. Always keep the area around the vehicle, winch, winch cable and load clear of people (especially children) and distractions while operating the winch.
8. Always turn the vehicle ignition power OFF when it and the winch are not being used.
9. Always be sure that at least five full turns of winch cable are wrapped around the winch drum at all times. The friction provided by this wrapped cable allows the drum to pull on the winch cable and move the load.
10. Always apply your vehicle’s park brake and/or park mechanism to hold the vehicle in place during winching. Use wheel chocks if needed.
11. Always align the vehicle and winch with the load directly in front of the vehicle as much as possible. Avoid winching with the winch cable at an angle to the winching vehicle’s center line whenever possible.
12. If winching at an angle is unavoidable, follow these precautions:
  - A. Look at the winch drum occasionally. Never let the winch cable “stack” or accumulate at one end of the winch drum. Too much winch cable at one end of the winch drum can damage the winch and the winch cable.
  - B. If stacking occurs, stop winching. Follow step 15 on page 4 to feed and rewind the cable evenly before continuing the winch operation.
13. Never winch up or down at sharp angles. This can destabilize the winching vehicle and possibly cause it to move without warning.
14. Never attempt to winch loads that weigh more than the winch’s rated capacity.
15. The winch motor may become hot during winch use. If you winch for more than 45 seconds, or if the winch stalls during operation, stop winching and permit the winch to cool down for 10 minutes before using it again.

## WINCH SAFETY PRECAUTIONS (continued)

16. Never touch, push, pull or straddle the winch cable while winching a load.
17. Never let the winch cable run through your hands, even if wearing heavy gloves.
18. Never release the clutch on the winch when the winch cable is under load.
19. Never use the winch for lifting or transporting people.
20. Never use the winch to hoist or suspend a vertical load.
21. Never immerse or submerge your winch in water. Take your winch to your dealer for service if this occurs.
22. Always inspect your winch and winch cable before each use.
23. Never winch the hook fully into the winch. This can cause damage to winch components.
24. Unplug the remote control from the vehicle when the winch is not in use to prevent inadvertent activation and use by unauthorized persons.
25. Never grease or oil the winch cable. This will cause the winch cable to collect debris that will shorten the life of the cable.

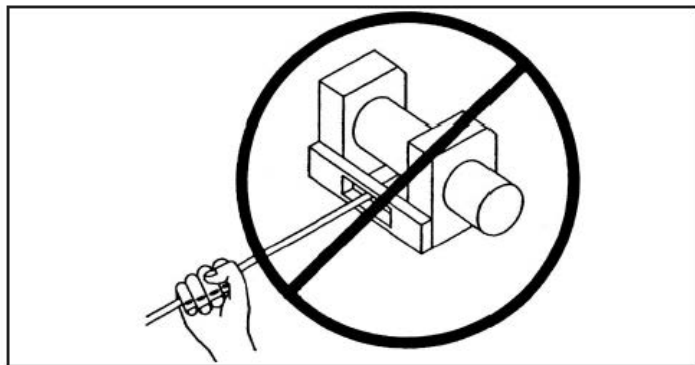

## WINCH OPERATION

Read the *Winch Safety Precautions* in the preceding pages before using your winch.

**TIP:** Consider practicing the operation and use of your winch before you actually need to use it in the field.

**! WARNING**

**ALWAYS** follow all winch instructions and warnings in this manual. Improper winch use can result in SEVERE INJURY or DEATH.

Each winching situation is unique:

- Take your time to think through the winching you are about to do.
  - Proceed slowly and deliberately.
  - Never hurry or rush during winching.
  - Always pay attention to your surroundings.
  - You may need to change your winching strategy if it is not working.
  - Always remember that your winch is very powerful.
  - There are simply some situations that you and your winch will not be able to deal with. Do not be afraid to ask others to help when this happens.
1. Always inspect the vehicle, winch, winch cable and winch controls for any signs of damage or parts in need of repair or replacement before each use. **Pay particular attention to the first three feet (one meter) of the winch cable if the winch is being used (or has been used) for lifting an accessory plow assembly.** Promptly replace any worn or damaged cable.
  2. Never operate a winch or a vehicle in need of repair or service.
  3. Always apply your vehicle's parking brake and/or park mechanism to hold the vehicle in place during winching. Use wheel chocks if needed.
  4. Always use the hook strap when handling the hook.

**! WARNING**

**NEVER** put your fingers into the hook. This could lead to SEVERE INJURY.

- A. Attach the hook itself onto the load or use a tow strap or chain to secure the load to the winch cable.

**TIP:** A "tow strap" is NOT intended to stretch. A "recovery strap" is designed to stretch.

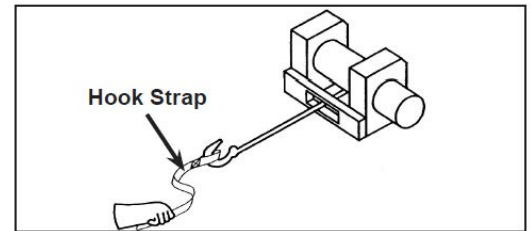

**! WARNING**

**NEVER** use a recovery strap when winching due to the excessive energy that can be released if the winch cable breaks. This can result in SEVERE INJURY or DEATH. See the Shock Loading section on page 15.

## WINCH OPERATION (continued)

- B. Never hook the winch cable back onto itself. This will damage the winch cable and may result in winch cable failure.

 **WARNING**

**ALWAYS** replace the winch cable at the first sign of damage to prevent SEVERE INJURY or DEATH in the event of a failure. For your safety, always replace KOLPIN winch parts (including the cable) with KOLPIN replacement parts available at your authorized KOLPIN dealer or the KOLPIN website.

- C. If possible, keep the winch cable aligned with the center line of the winching vehicle. This will help the spooling of the winch cable and reduce the load on the fairlead.
- D. If freeing a stuck vehicle by attaching to a tree, use an item such as a tow strap to avoid damaging the tree during winch operation. Sharp cables and chains can damage and even kill trees. Please remember to Tread Lightly® (treadlightly.org).

- E. Before operating the winch, be sure that the safety latch on the winch cable hook is fully seated when the load is attached.
- F. Never operate your winch with a damaged hook or latch. Always replace damaged parts before using the winch.

5. Never remove the hook strap from the hook.

6. Release the winch clutch and pull out the winch cable.

7. Pulling out as much cable as possible maximizes the winch's pulling capacity.

Always be sure that at least five full turns of winch cable are wrapped around the winch drum at all times. The friction provided by this wrapped cable allows the drum to pull on the winch cable and move the load.

8. Read and adhere to the following information for winch damping to ensure safe winch use.

- A. In order to absorb energy that could be released by a winch cable failure, always place a "damper" on the winch cable. A damper can be a heavy jacket, tarp, or other soft, dense object. A damper can absorb much of the energy released if a winch cable breaks when winching. Even a tree limb can help as a damper if no other items are available to you.
- B. Lay the damper on top of the mid-point of the winch cable length that is spooled out.
- C. On a long pull, it may be necessary to stop winching so that the damper can be repositioned to the new mid-point of the winch cable. Always release the tension on the winch cable before repositioning the damper.
- D. Avoid being directly in line with the winch cable whenever possible. Also, never permit others to stand near or in line with the winch cable during winch operation.

9. Never hook the winch cable back onto itself. This will damage the winch cable and may result in winch cable failure.

10. Never use straps, chains or other rigging items that are damaged or worn.

11. The **ONLY** time a winch-equipped vehicle should be moving when using the winch is when the vehicle itself is stuck. The winch equipped vehicle should **NEVER** be in motion to "shock" load the winch cable in an attempt to move a second stuck vehicle. See the **Shock Loading** section on page 14. For your safety, always follow these guidelines when winching a vehicle free:

- A. Release the winch clutch and spool out the necessary length of winch cable.
- B. Align the winch cable as close as possible to the winching vehicle's center line.
- C. Attach the winch cable hook to the anchor point or the stuck vehicle's frame following instructions in this manual.
- D. Re-engage the clutch on the winch.
- E. Slowly winch in the slack in the winch cable.
- F. Select the proper vehicle gear to propel the stuck vehicle in the direction of winching.
- G. Shift to the lowest gear available on the stuck vehicle.
- H. Slowly and carefully apply vehicle throttle and winch together to free the vehicle.
- I. Stop winching as soon as the stuck vehicle is able to propel itself without the help of the winch.
- J. Detach the winch cable hook.
- K. Rewind the winch cable evenly back onto the winch drum following the instructions in this manual.

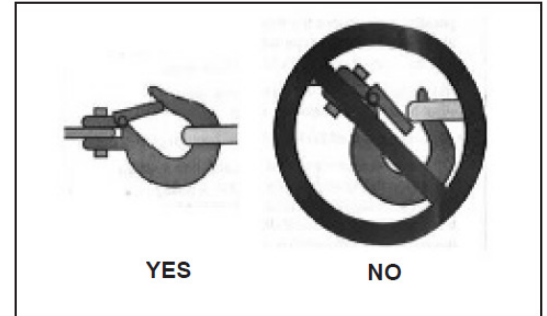

## WINCH OPERATION (continued)

12. Never attempt to winch another stuck vehicle by attaching the winch cable to a suspension component, brush guard, bumper or cargo rack. Vehicle damage may result. Instead, attach the winch to a strong portion of the vehicle frame or hitch.
13. Extensive winching will run down the battery on the winching vehicle. Let the winching vehicle's engine run while operating the winch to prevent the battery from running low if winching for long periods.
14. The winch motor may become hot during winch use. If you winch for more than 45 seconds, or if the winch stalls during operation, stop winching and permit the winch to cool down for 10 minutes before using it again.
15. After winching is complete, especially if winching at an angle, it may be necessary to re-distribute the winch cable across the winch drum. You will need an assistant to perform this task.
  - A. Release the clutch on the winch.
  - B. Feed out the winch cable that is unevenly bunched up in one area.
  - C. Re-engage the winch clutch.
  - D. Have an assistant pull the winch cable tightly with about 100 lbs. (45 kg) of tension using the hook strap.
  - E. Slowly winch the cable in while your assistant moves the end of the winch cable back and forth horizontally to evenly distribute the winch cable on the drum.
  - F. Doing this reduces the chances of the winch cable "wedging" itself between lower layers of winch cable.

## WINCH CABLE CARE

For your safety, always replace KOLPIN winch parts (including the cable) with KOLPIN replacement parts available at your authorized KOLPIN dealer or the KOLPIN website (Kolpin.com).

 **WARNING**

**NEVER** use a worn or damaged cable. Use of a worn or damaged cable could lead to sudden failure and SEVERE INJURY.

1. Always inspect your winch before each use. Inspect for worn or loose parts including mounting hardware. Never use the winch if any part needs repair or replacement.
2. Always inspect your winch cable before each use. Inspect for worn or kinked winch cable.
  - A. A kinked winch cable made of wire rope is shown at right. Even after being "straightened out," this cable has already been permanently and severely damaged. Promptly discontinue use of a winch cable in this condition.
  - B. A kinked winch cable made of wire rope that has been "straightened out" is shown at right. Even though it may look usable, the cable has been permanently and severely damaged. It can no longer transmit the load that it could prior to kinking. Promptly discontinue use of a winch cable in this condition.
  - C. A winch cable made of synthetic rope should be inspected for signs of fraying. Replace the cable if fraying is observed (shown at right). Promptly discontinue use of a winch cable in this condition.
  - D. Also replace the winch cable if there are fused or melted fibers. Such an area of the synthetic rope will be stiff and appear smooth or glazed. Promptly discontinue use of a winch cable in this condition.

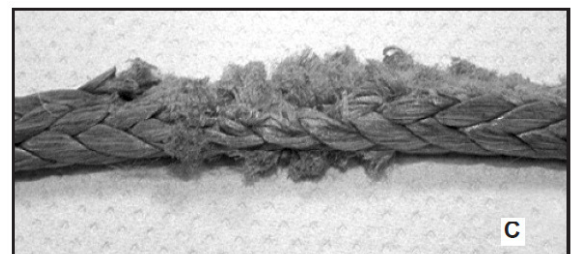
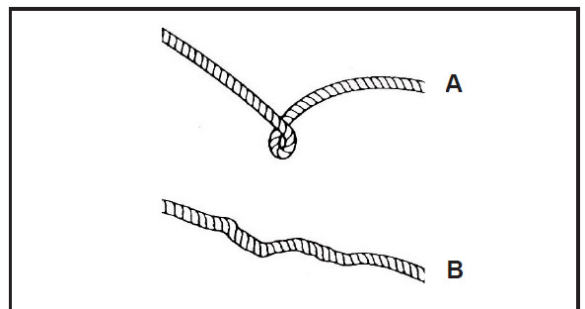

## SHOCK LOADING

 <b>WARNING</b>
<p><b>NEVER</b> shock load a winch cable. Your winch cable is very strong but it is NOT designed for dynamic, or “shock” loading. Shock loading may tension a winch cable beyond its strength and cause the cable to break. The end of a broken winch cable under such high loading can cause SEVERE INJURY or DEATH to you and other bystanders.</p>

*Winch cables are designed to NOT absorb energy. This is true of both wire-rope and synthetic-rope winch cables.*

1. Never attempt to “jerk” a load with the winch. For example, never take up slack in the winch cable by moving the winching vehicle in an attempt to move an object. This is a dangerous practice. It generates high winch cable loads that may exceed the strength of the cable. Even a slowly moving vehicle can create large shock loads in a winch cable.

 <b>WARNING</b>
<p><b>NEVER</b> use a broken winch cable. SEVERE INJURY or DEATH can result.</p>

2. Never quickly turn the winch ON and OFF repeatedly (“jogging”). This puts extra load on the winch, winch cable, and generates excessive heat from the motor. This is a form of shock loading.
3. Never tow a vehicle or other object with your winch. Towing an object with a winch produces shock loading of the cable even when towing at slow speeds. Towing from a winch also positions the towing force high on the vehicle. This can cause instability of the vehicle and possibly lead to an accident.
4. Never use recovery straps with your winch. Recovery straps are designed to stretch and can store energy. This stored energy in the recovery strap is released if a winch cable fails making the event even more hazardous. Similarly, never use elastic “bungee” cords for winching.
5. Never use the winch to tie down a vehicle to a trailer or other transportation vehicle. This type of use also causes shock loading that can cause damage to the winch, winch cable, or vehicles used.
6. *Your winch cable is designed and tested to withstand the loads produced by the winch motor when operated from a stationary vehicle. Always remember that the winch and winch cable are NOT designed for shock loading.*

## WINCH MAINTENANCE AND SERVICE SAFETY

### **WARNING**

**ALWAYS** follow all winch instructions and warnings in this manual. Improper or lack of winch maintenance and service could lead to SEVERE INJURY or DEATH.

1. Always inspect your winch before each use. Inspect for worn or kinked winch cable. Also inspect for worn or loose parts including mounting hardware.
2. Permit your winch motor to cool down prior to servicing your winch.
3. Never work on your winch without first disconnecting the battery connections to prevent accidental activation of the winch
4. For your safety, always replace KOLPIN winch parts (including the cable) with KOLPIN replacement parts available at your authorized KOLPIN dealer or the KOLPIN website (Kolpin.com).
5. Some winch models use wire rope as the winch cable. Other winches use a specially designed synthetic rope as the winch cable.
6. Never replace a synthetic-rope winch cable with a consumer-grade polymer rope such as can be purchased in a hardware store. Although they may look similar, they are NOT alike. A polymer rope not designed for winch use will stretch and store excessive energy when winching.

### **WARNING**

**ALWAYS** be aware that failure of a stretched rope under winching conditions will release all of the stored energy. This will increase the chances of SEVERE INJURY or DEATH.

## LUBRICATION

All moving parts within the electric winch have been lubricated using high temperature grease at the factory. No internal lubrication is required. Never grease or oil the winch cable. This will cause the winch cable to collect debris that will shorten the life of the cable.

## CABLE ASSEMBLY REPLACEMENT

It is recommended that only KOLPIN supplied parts be used.

1. Move the clutch to the “free-spool” position.
2. Extend cable assembly to its full length. Note how the existing cable is connected to the inside of the drum.
3. Remove old cable assembly and attach new one.
4. Retract cable assembly onto drum being careful not to allow kinking.

### **NOTE**

For service or parts assistance, contact our help line at **1-877-956-5746**.



# PERFORMANCE SPECIFICATIONS

- Motor: 12V DC, permanent magnet type, heavy duty
  - 1.1 HP ..... 2500 lb. rated pull
  - 1.2 HP ..... 3500 lb. rated pull
  - 1.3 HP ..... 4500 lb. rated pull
- Motor duty cycle: Intermittent
- Gear reduction ratio ..... 166 : 1
- Brake: Mechanical
- Electric cable leads ..... 8 gauge (2500 lb. & 3500 lb.), 6 gauge (4500 lb.)
- Winch cable size:
  - 50' length x 3/16" diameter wire rope (3/16" diameter synthetic model) ..... 2500 lb. rated pull
  - 50' length x 7/32" diameter wire rope (3/16" diameter synthetic model) ..... 3500 lb. rated pull
  - 50' length x 7/32" diameter wire rope (1/4" diameter synthetic model) ..... 4500 lb. rated pull
- Drum size: 50mm diameter x 74mm length

**2500 lb. Specifications:**

Line Pull (lbs)	Line Speed (ft/min)	Motor (amps)
0	25	24
500	18	50
1500	15	118
2500	9	210

**3500 lb. Specifications:**

Line Pull (lbs)	Line Speed (ft/min)	Motor (amps)
0	23	24
500	17	56
1500	14	120
2500	9	220
3500	7	240

**4500 lb. Specifications:**

Line Pull (lbs)	Line Speed (ft/min)	Motor (amps)
0	23	29
500	17	60
1500	14	130
2500	9	225
3500	7	260
4500	5	310

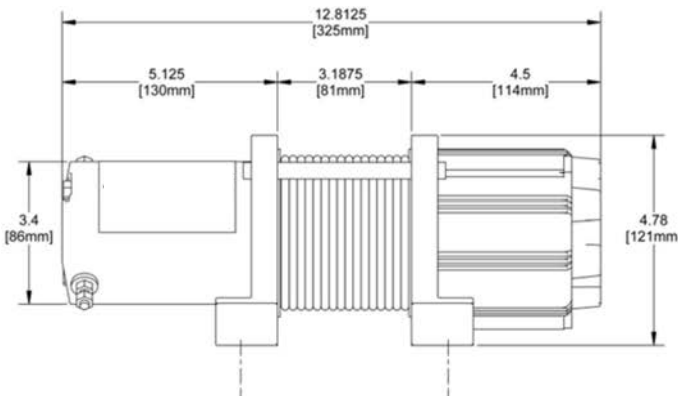

Winch Dimensions - Front View

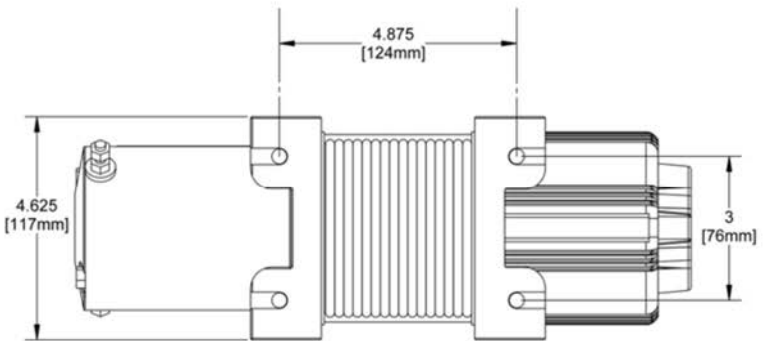

Winch Dimensions - Bottom View

**25-9250 Kit Contents (2500 lb) and Replacement Part Numbers:**

Item	Qty	Part Description	Replacement Part Number
1	1	Replacement Winch 2500#	25-9250R
2	1	Kolpin winch hook strap, orange	85071
3	1	Kolpin steel cable, 3/16" diameter x 50' length	85062
4	1	Rocker switch	85066
5	1	Contactora/solenoid	85068
6	1	Roller fairlead	85069
7	2	Lock washer, M4	-
8	2	Flat washer, M4	-
9	1	Scotch lock	-
10	6	Cable tie, 8"	-
11	2	Hex nut, M4	-
12	8	Flat washer, M8	-
13	4	Hex nut, M8 x 1.25	-
14	4	Lock washer, M8	-
15	6	Hex bolt, M8 x 1.25 x 25mm zinc plated	-
16	2	Hex bolt, M8 x 1.25 x 20mm zinc plated	-
17	6	Terminal cap	RPR0109
18	1	Clevis hook	RPR0108
19	1	Cable, red, 8-gauge, 36"	85089
20	1	Cable, black, 8-gauge, 36"	85089
21	1	Cable, yellow, 8-gauge, 96"	85090
22	1	Cable, blue, 8-gauge, 96"	85090
23	1	Universal Fairlead Mount Bracket	-
24	2	Pan screw, M4 x 30	-

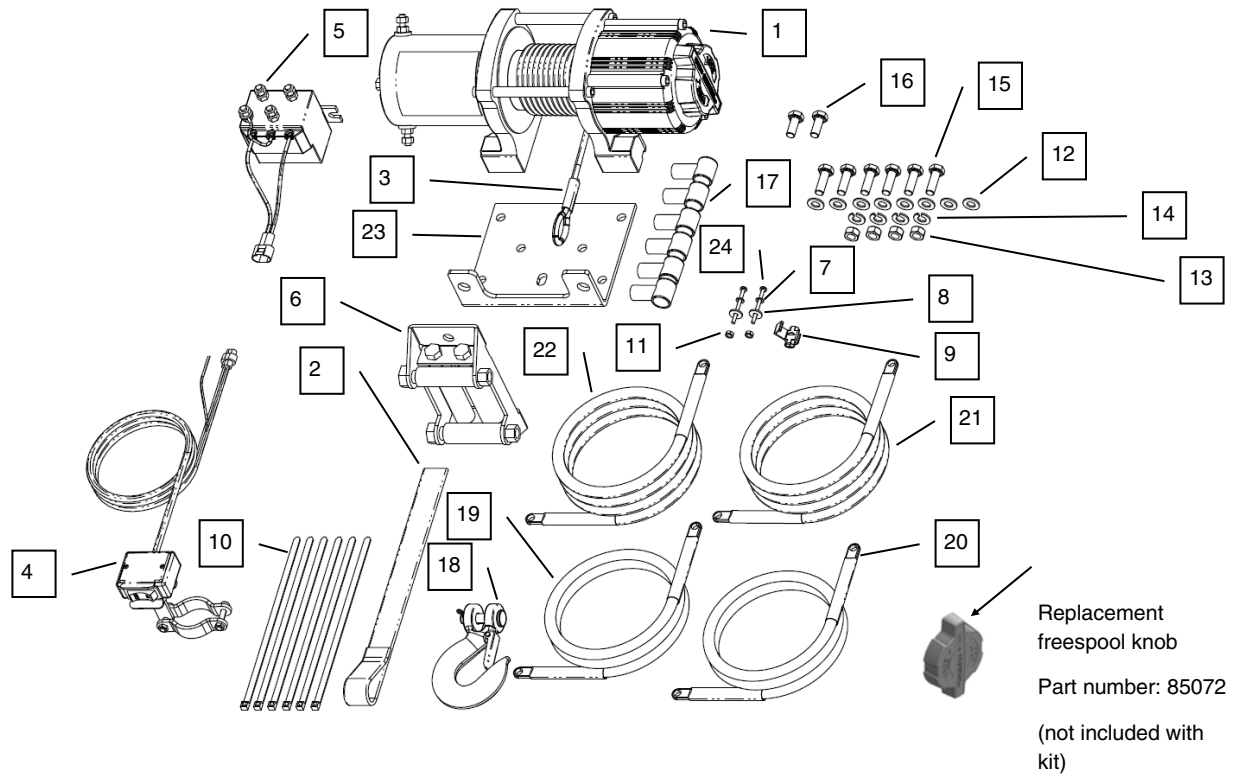

**25-9255 Kit Contents (2500 lb) and Replacement Part Numbers:**

Item	Qty	Part Description	Replacement Part Number
1	1	Replacement Winch 2500#	25-9250R
2	1	Kolpin winch hook strap, orange	85071
3	1	Kolpin synthetic rope, 1/4" diameter x 50' length	85064
4	1	Rocker switch	85066
5	1	Contactator/solenoid	85068
6	1	Roller fairlead	85069
7	2	Lock washer, M4	-
8	2	Flat washer, M4	-
9	1	Scotch lock	-
10	6	Cable tie, 8"	-
11	2	Hex nut, M4	-
12	8	Flat washer, M8	-
13	4	Hex nut, M8 x 1.25	-
14	4	Lock washer, M8	-
15	6	Hex bolt, M8 x 1.25 x 25mm zinc plated	-
16	2	Hex bolt, M8 x 1.25 x 20mm zinc plated	-
17	6	Terminal cap	RPR0109
18	1	Clevis hook	RPR0108
19	1	Cable, red, 8-gauge, 36"	85089
20	1	Cable, black, 8-gauge, 36"	85089
21	1	Cable, yellow, 8-gauge, 96"	85090
22	1	Cable, blue, 8-gauge, 96"	85090
23	1	Winch Stop	85080
24	1	Universal Fairlead Mount Bracket	-
25	2	Pan screw, M4 x 30	-

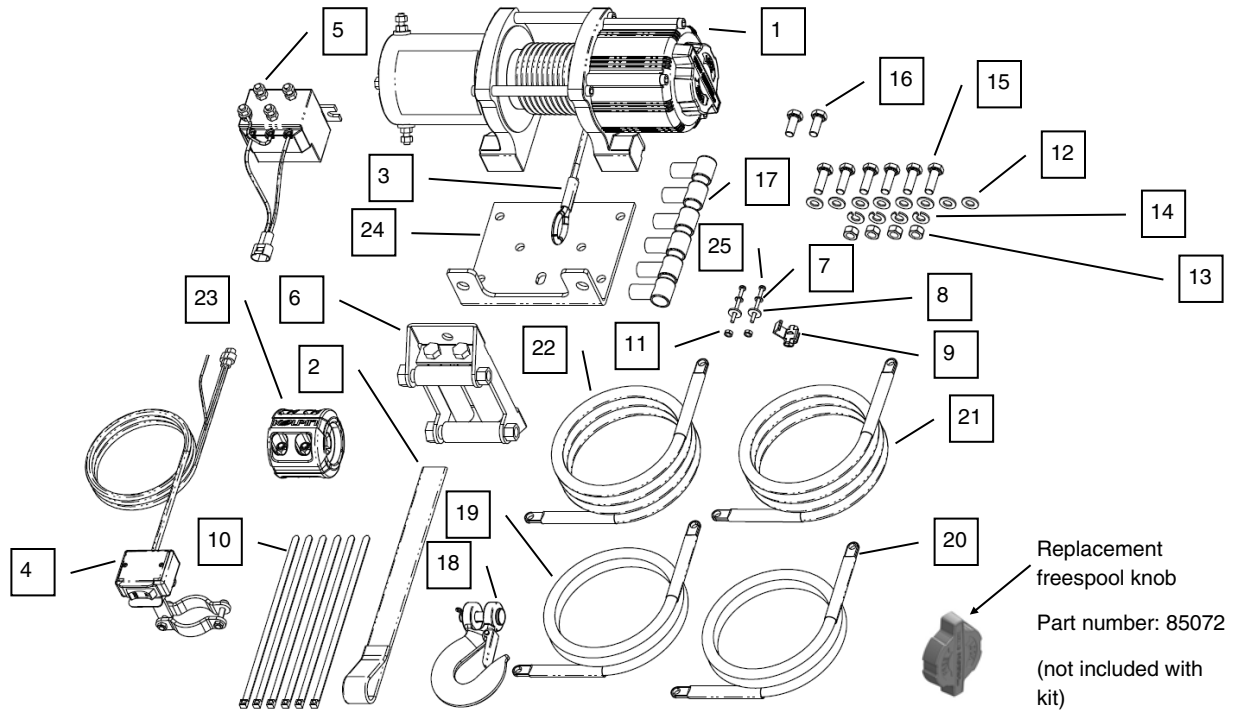

**25-9350 Kit Contents (3500 lb) and Replacement Part Numbers:**

Item	Qty	Part Description	Replacement Part Number
1	1	Replacement Winch 3500#	25-9350R
2	1	Kolpin winch hook strap, orange	85071
3	1	Kolpin steel cable, 7/32" diameter x 50' length	85063
4	1	Rocker switch	85066
5	1	Contactor/solenoid	85068
6	1	Roller fairlead	85069
7	2	Lock washer, M4	-
8	2	Flat washer, M4	-
9	1	Scotch lock	-
10	6	Cable tie, 8"	-
11	2	Hex nut, M4	-
12	8	Flat washer, M8	-
13	4	Hex nut, M8 x 1.25	-
14	4	Lock washer, M8	-
15	6	Hex bolt, M8 x 1.25 x 25mm zinc plated	-
16	2	Hex bolt, M8 x 1.25 x 20mm zinc plated	-
17	6	Terminal cap	RPR0109
18	1	Clevis hook	RPR0108
19	1	Cable, red, 8-gauge, 36"	85089
20	1	Cable, black, 8-gauge, 36"	85089
21	1	Cable, yellow, 8-gauge, 96"	85090
22	1	Cable, blue, 8-gauge, 96"	85090
23	1	Corded Remote Switch	85067
24	1	Universal Fairlead Mount Bracket	-
25	2	Pan screw, M4 x 30	-

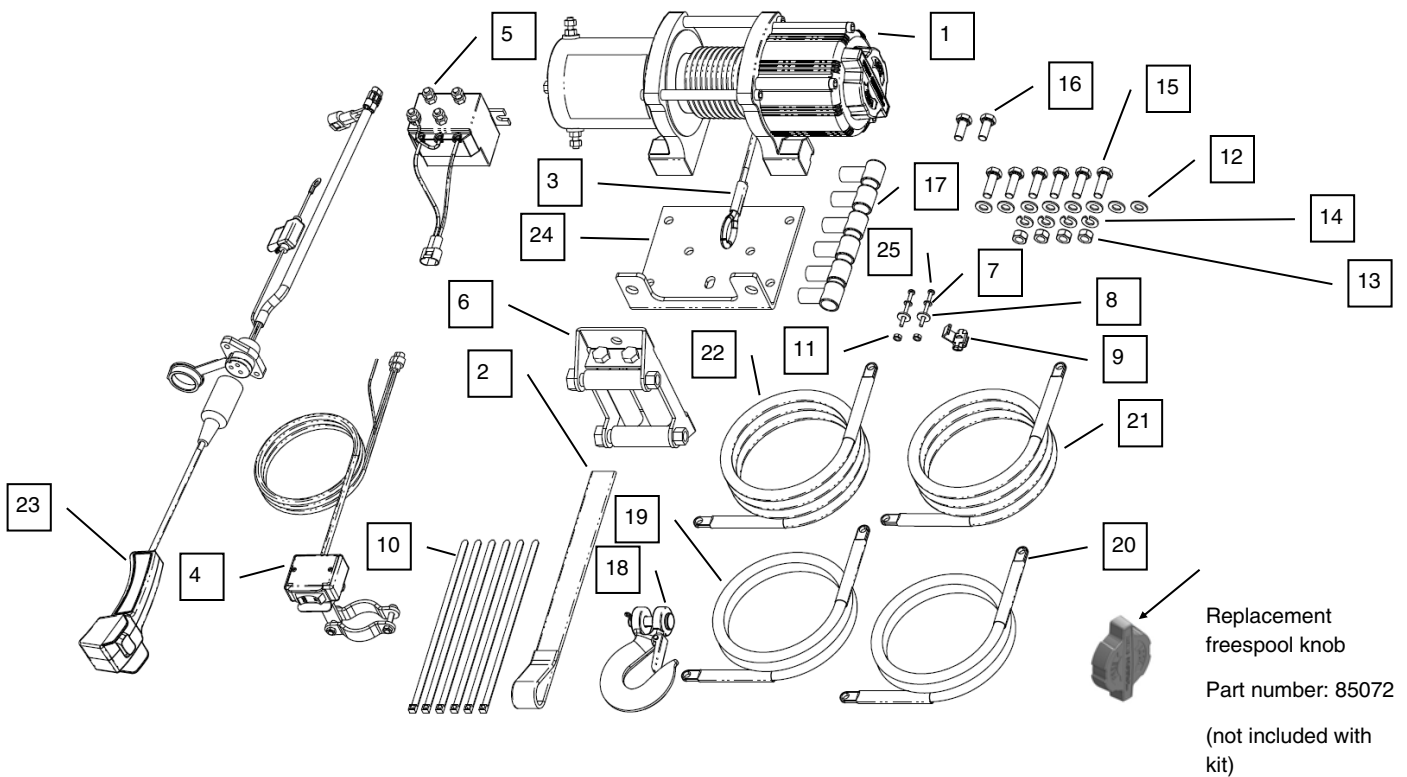

**25-9355 Kit Contents (3500 lb) and Replacement Part Numbers:**

Item	Qty	Part Description	Replacement Part Number
1	1	Replacement Winch 3500#	25-9350R
2	1	Kolpin winch hook strap, orange	85071
3	1	Kolpin synthetic rope, 1/4" diameter x 50' length	85064
4	1	Rocker switch	85066
5	1	Contactora/solenoid	85068
6	1	Roller fairlead	85069
7	2	Lock washer, M4	-
8	2	Flat washer, M4	-
9	1	Scotch lock	-
10	6	Cable tie, 8"	-
11	2	Hex nut, M4	-
12	8	Flat washer, M8	-
13	4	Hex nut, M8 x 1.25	-
14	4	Lock washer, M8	-
15	6	Hex bolt, M8 x 1.25 x 25mm zinc plated	-
16	2	Hex bolt, M8 x 1.25 x 20mm zinc plated	-
17	6	Terminal cap	RPR0109
18	1	Clevis hook	RPR0108
19	1	Cable, red, 8-gauge, 36"	85089
20	1	Cable, black, 8-gauge, 36"	85089
21	1	Cable, yellow, 8-gauge, 96"	85090
22	1	Cable, blue, 8-gauge, 96"	85090
23	1	Winch Stop	85080
24	1	Corded Remote Switch	85067
25	1	Universal Fairlead Mount Bracket	-
26	2	Pan screw, M4 x 30	-

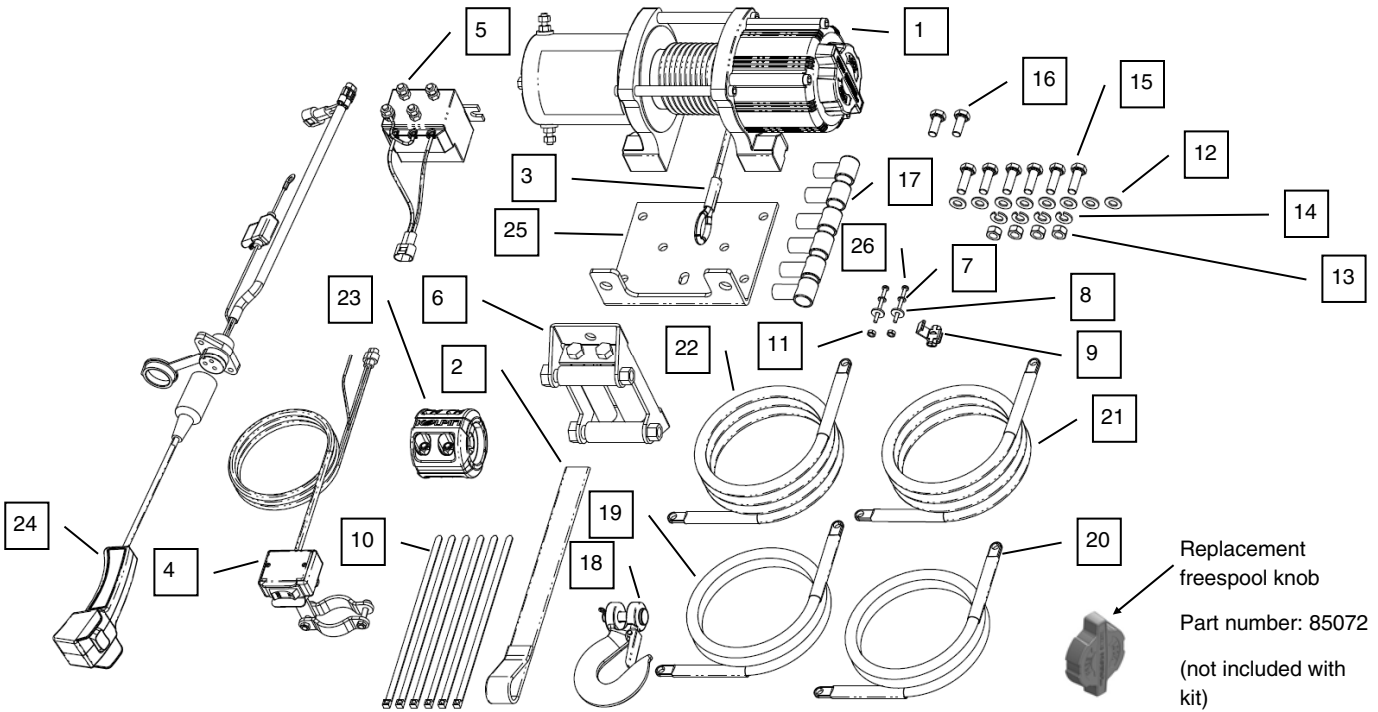

**25-9450 Kit Contents (4500 lb) and Replacement Part Numbers:**

Item	Qty	Part Description	Replacement Part Number
1	1	Replacement Winch 4500#	25-9450R
2	1	Kolpin winch hook strap, orange	85071
3	1	Kolpin steel cable, 7/32" diameter x 50' length	85063
4	1	Rocker switch	85066
5	1	Contactora/solenoid	85068
6	1	Roller fairlead	85069
7	2	Lock washer, M4	-
8	2	Flat washer, M4	-
9	1	Scotch lock	-
10	6	Cable tie, 8"	-
11	2	Hex nut, M4	-
12	8	Flat washer, M8	-
13	4	Hex nut, M8 x 1.25	-
14	4	Lock washer, M8	-
15	6	Hex bolt, M8 x 1.25 x 25mm zinc plated	-
16	2	Hex bolt, M8 x 1.25 x 20mm zinc plated	-
17	6	Terminal cap	RPR0109
18	1	Clevis hook	RPR0108
19	1	Cable, red, 6-gauge, 36"	85089
20	1	Cable, black, 6-gauge, 36"	85089
21	1	Cable, yellow, 6-gauge, 96"	85090
22	1	Cable, blue, 6-gauge, 96"	85090
23	1	Corded Remote Switch	85067
24	1	Dash Mount Bracket	85082
25	1	Universal Fairlead Mount Bracket	-
26	2	Pan screw, M4 x 30	-

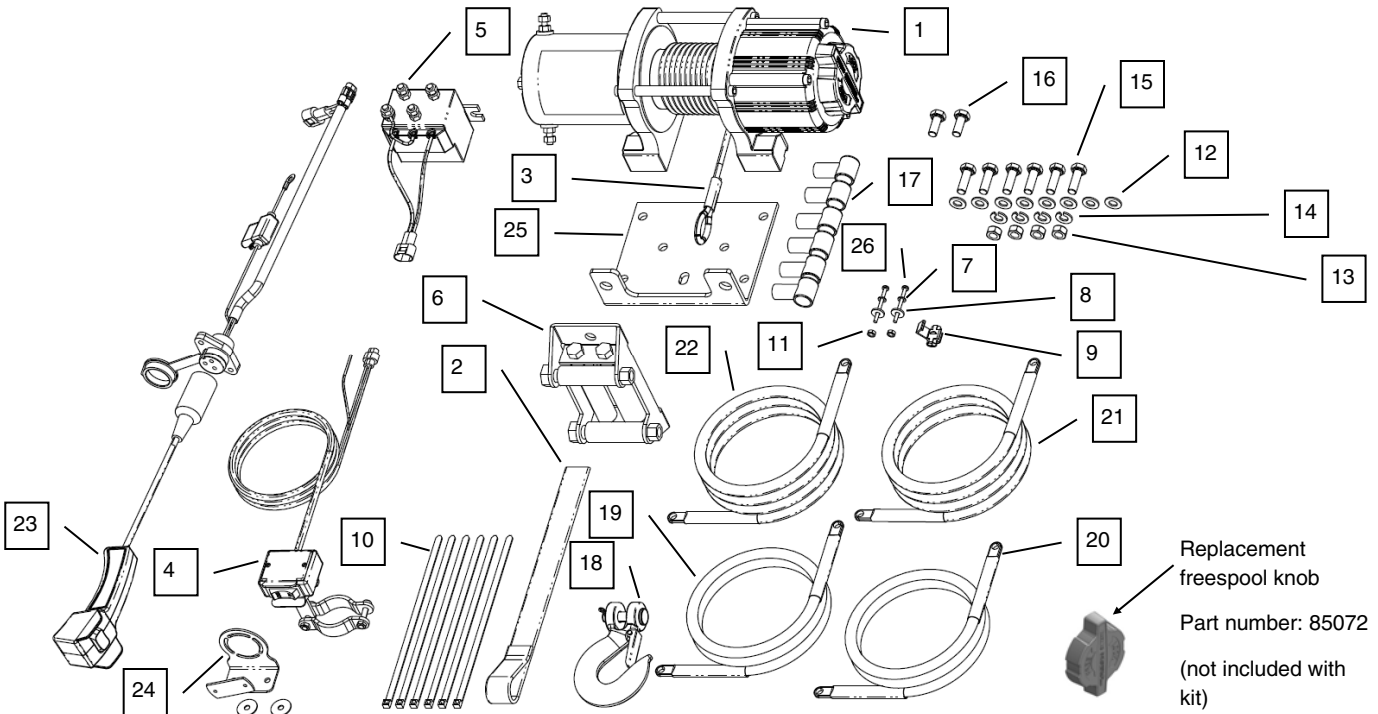

**25-9455 Kit Contents (4500 lb) and Replacement Part Numbers:**

Item	Qty	Part Description	Replacement Part Number
1	1	Replacement Winch 4500#	25-9450R
2	1	Kolpin winch hook strap, orange	85071
3	1	Kolpin synthetic rope, 1/4" diameter x 50' length	85064
4	1	Rocker switch	85066
5	1	Contactor/solenoid	85068
6	1	Roller fairlead	85069
7	2	Lock washer, M4	-
8	2	Flat washer, M4	-
9	1	Scotch lock	-
10	6	Cable tie, 8"	-
11	2	Hex nut, M4	-
12	8	Flat washer, M8	-
13	4	Hex nut, M8 x 1.25	-
14	4	Lock washer, M8	-
15	6	Hex bolt, M8 x 1.25 x 25mm zinc plated	-
16	2	Hex bolt, M8 x 1.25 x 20mm zinc plated	-
17	6	Terminal cap	RPR0109
18	1	Clevis hook	RPR0108
19	1	Cable, red, 6-gauge, 36"	85089
20	1	Cable, black, 6-gauge, 36"	85089
21	1	Cable, yellow, 6-gauge, 96"	85090
22	1	Cable, blue, 6-gauge, 96"	85090
23	1	Winch Stop	85080
24	1	Corded Remote Switch	85067
25	1	Dash Mount Bracket	85082
26	1	Universal Fairlead Mount Bracket	-
27	2	Pan screw, M4 x 30	-

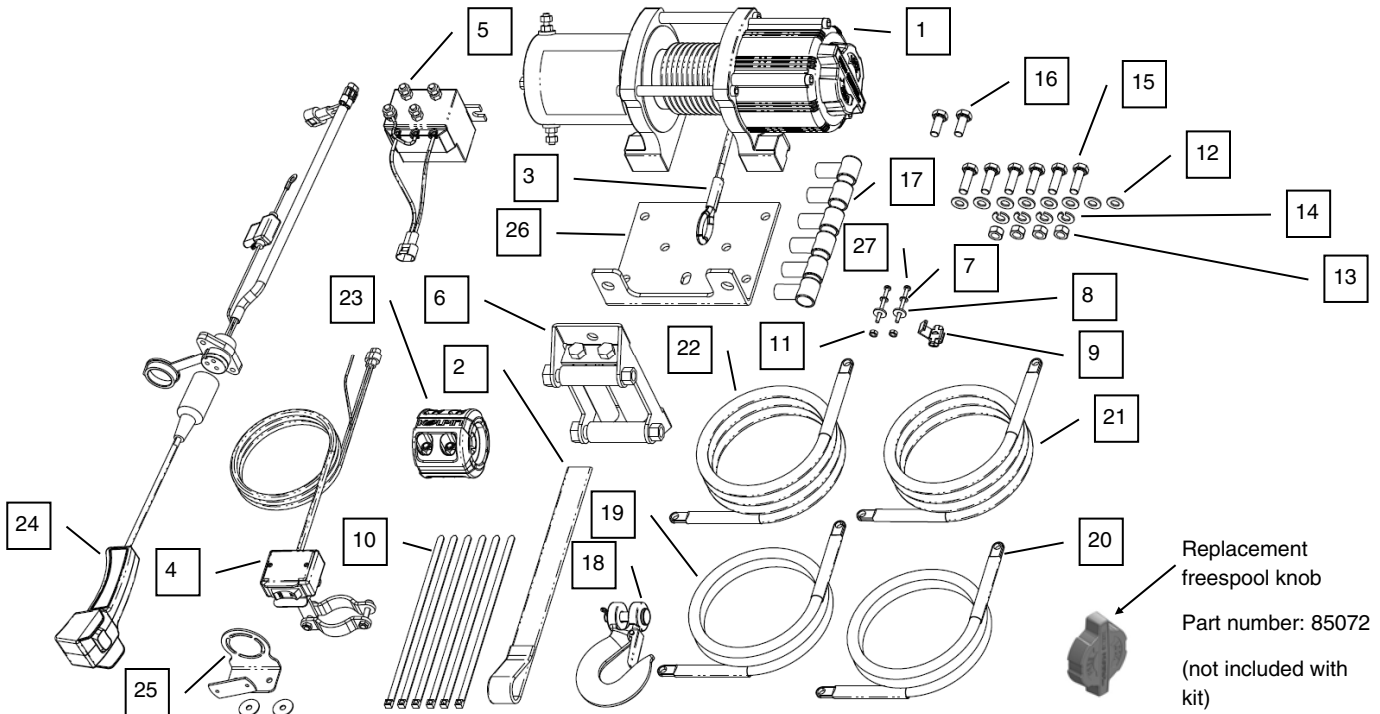



## TROUBLESHOOTING

Problem	Cause	Solution
Motor does not turn	Switch assembly not connected properly	Insert switch assembly all the way into the connector.
	Loose battery cable connections	Tighten nuts on all cable connections.
	Contactor malfunctioning	Tap contactor to loosen contacts. Apply 12 volts to coil terminals directly. A clicking indicates proper activation.
	Defective switch assembly	Replace switch assembly.
	Defective motor	Check for voltage at armature port with switch pressed. If voltage is present, replace winch assembly.
	Nested and bounded cable within winch assembly	Move freespool knob to the "free spool" position. Manually pull cable out of winch until end is met and then re-spool cable back into winch.
	Water has entered motor	Allow to drain and dry. Run in short bursts without load until completely dry.
Motor runs but cable drum does not turn	Clutch (freespool knob) not engaged	Move freespool knob to the "locked spool" position. If problem persists, a qualified technician needs to check and repair.
Motor runs slowly or without normal power	Insufficient current or voltage	The battery is weak, recharge. Run winch with vehicle motor running (battery should have a strong charge).
	Loose or corroded battery cable connections	Clean, tighten, or replace.
Motor overheating	Winch running time too long	Allow winch to cool down periodically.
Motor runs in one direction only	Defective or stuck contactor	Tap contactor to loosen contacts.
		Repair or replace contactor.
	Defective switch assembly	Replace switch assembly.
	Defective brake assembly	Replace winch assembly.

***Note: If any hardware is missing, do not return to the store. Call us to help, Toll Free 1-877-956-5746.***

### NOTE

For further technical support, contact our help line at **1-877-956-5746**.



## **Five Year Mechanical Limited Warranty and Three Year Electrical Limited Warranty**

For the period of five (5) years from the purchase date, Kolpin will replace for the original purchaser, free of charge, any mechanical part or mechanical parts found upon examination by Kolpin to be defective in material, workmanship, or both. For the period of three (3) years from the purchase date, Kolpin will replace for the original purchaser, free of charge, any electrical part or electrical parts found upon examination by Kolpin to be defective in material, workmanship, or both.

All transportation costs incurred submitting product to Kolpin for warranty consideration must be borne by the purchaser. If Kolpin determines that the product must be returned to the factory for credit, please call 1-877-956-5746 for a Return Merchandise Authorization (RMA) number and shipping instructions.

This warranty does not apply to parts that have been damaged by accident, alteration, abuse, improper maintenance, normal wear, or other causes beyond the manufacturer's control. In order to protect you and your ATV, certain parts of the winch/plow system and/or hardware are designed to fail when the equipment is over-stressed. Parts that are lost due to loosening and improper maintenance are not covered under warranty. This warranty does not cover removal or reinstallation labor fees of the winch/plow system and related components.

Peripheral products such as engines, electric motors, and actuators may carry an original manufacturer's warranty. Most hardware is general in nature and is easily obtained locally. Be sure to replace with minimum metric class 8.8 specification.

**Kolpin Outdoors, Inc.**

**Telephone: (763)-478-5800**

**Toll Free: (877)-956-5746**

**Fax Number: (800)-245-7569**

**[www.kolpin.com](http://www.kolpin.com)**

**Email: [customerservice@kolpin.com](mailto:customerservice@kolpin.com)**



**10-0145 Plow Marker Kits**  
**Owner's Manual / Guide du propriétaire**

Place the plow markers 1" inside the outer edge on the top of the plow blade.  
Mark the blade with a paint pen. Drill a 5/16" hole at the mark and attach  
the plow marker with the provided 5/16" x 1" bolt, flat washers and nylock nut.

**\*\*\*WARNING\*\*\***

Be sure to drill hole in correct spot  
Know that the blade is still wider than the marker shows  
Drill can be dangerous... use caution

*Placez les repères pour chasse-neige à 1 po à l'intérieur du rebord et à environ 1 po du dessus de la lame. Marquez l'emplacement du repère à l'aide d'un stylo à retouches. Percez un trou de 5/16 po à la marque et fixez le repère pour chasse-neige en utilisant le boulon de 5/16 x 1 po, les rondelles plates et l'écrou nylock fournis.*

**\*\*\*Avertissement\*\*\***

*Assurez-vous de percer le trou au bon endroit.  
Souvenez-vous que la lame dépasse légèrement des repères.  
Soyez prudent lors de l'utilisation d'une perceuse.*



**10-0145 Plow Marker Kits**  
**Owner's Manual / Guide du propriétaire**

Place the plow markers 1" inside the outer edge on the top of the plow blade.  
Mark the blade with a paint pen. Drill a 5/16" hole at the mark and attach  
the plow marker with the provided 5/16" x 1" bolt, flat washers and nylock nut.

**\*\*\*WARNING\*\*\***

Be sure to drill hole in correct spot  
Know that the blade is still wider than the marker shows  
Drill can be dangerous... use caution

*Placez les repères pour chasse-neige à 1 po à l'intérieur du rebord et à environ 1 po du dessus de la lame. Marquez l'emplacement du repère à l'aide d'un stylo à retouches. Percez un trou de 5/16 po à la marque et fixez le repère pour chasse-neige en utilisant le boulon de 5/16 x 1 po, les rondelles plates et l'écrou nylock fournis.*

**\*\*\*Avertissement\*\*\***

*Assurez-vous de percer le trou au bon endroit.  
Souvenez-vous que la lame dépasse légèrement des repères.  
Soyez prudent lors de l'utilisation d'une perceuse.*





# FRONT-CONNECT PLOW MOUNT KIT

FOR HONDA PIONEER 700

P/N 35-1010

## ASSEMBLY / INSTALLATION MANUAL

Application

FRONT-CONNECT PLOW PUSH FRAME NO. 35-0070

Before you begin, please read these instructions and check to be sure all parts and tools are accounted for. The following instructions contain details required to install and service the contents of this kit.

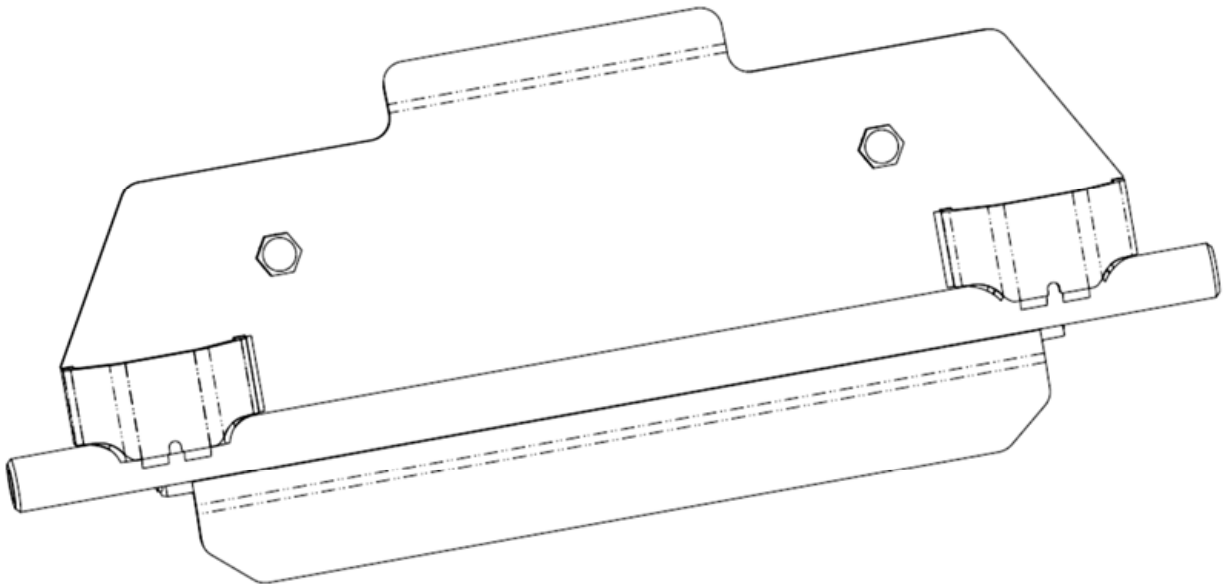

## INTRO

Thank you for purchasing Kolpin engineered products. With proper installation, usage, care, and maintenance, your Kolpin product will last for years to come.

## BEFORE YOU BEGIN

- Your Kolpin accessory is exclusively designed for your vehicle.
- Read and understand the entire installation manual, including all installation instructions, operating instructions, safety warnings and guidelines before installing or operating your accessory. Failure to comply may result in damage to the product and / or vehicle, and can lead to hazards up to and including death.
- • Verify all parts and tools are accounted for. If parts are missing, do not return to the store. Call us for help, **Toll Free 1-877-956- 5746**
- Follow all steps correctly and in the sequence described.
- Keep these instructions for future reference or for informational requests.
- To facilitate installation, make sure that your vehicle is clean and free of debris.
- All directions referring to right and left are from the rider perspective when sitting on the machine.

## ASSEMBLY TIME

Approximately 21 minutes

## SAFETY INFORMATION

Please read and understand all Cautions, Notices, and Warnings in this manual before you begin. In order to protect you and your ATV / UTV, certain parts of the plow system and / or hardware are designed to fail when the equipment is over-stressed.

**Follow these guidelines to ensure satisfactory operation:**

- Read this manual and your ATV / UTV operators manual before use.
- Periodically check for wear and tightness of all fasteners. Replace or re-torque fasteners as necessary.
- Before first use, set plow in the furthest right or left angled position to check for interference with the vehicle.
- Operate with extreme caution on slopes and rough terrain. Be familiar with the area before you plow.
- Be aware of immovable objects that could be hidden in the area you are plowing.
- To avoid damage when pushing snow into a pile, reverse direction before raising the plow blade.
- Do not ram the plow blade into piles of snow.
- For best results, set the suspension preload of your ATV / UTV to the stiffest setting.
- To reduce steering effort and increase mobility, set the air pressure of your tires to the maximum pressure specification.
- The plow skids are adjustable. General skid setting is even with the plow wear bar bottom edge, higher settings reduce the chance of rocks and gravel from being collected.
- To increase traction during plow operation, operators can try: Securing weight to the ATV / UTV for additional tire downforce, reducing tire air pressure, or installing tire chains.



## WARNING



### TO AVOID SERIOUS INJURY OR DEATH:

1. DO NOT EXCEED 5 MPH (8 KMH) WITH BLADE INSTALLED
2. OPERATE WITH EXTREME CAUTION ON SLOPES, STEEP GRADES, AND ROUGH TERRAIN
3. ALLOW NO RIDERS ON BLADE OR ATV WHILE MOVING OR STATIONARY
4. KEEP BYSTANDERS AWAY FROM THE BLADE OR ATV WHILE MOVING OR STATIONARY
5. WHEN PUSHING HEAVY MATERIAL, DIRECTION CONTROL MAY BECOME DIFFICULT
6. BEFORE ADJUSTING BLADE: STOP ATV ENGINE; SET AND LOCK BRAKES; RAISE AND LOCK BLADE
7. LOWER BLADE TO DOWN POSITION WHEN BLADE AND ATV ARE NOT IN USE
8. READ BLADE INSTRUCTION SHEETS AND ATV OWNER'S MANUAL

## REQUIRED SOLD SEPARATELY

Only parts for installation of the Plow Mounting Bracket Kit are included. For complete snow plow system installation, additional items are required such as a plow push frame, vehicle plow mount, winch, and winch mount. See [www.Kolpin.com](http://www.Kolpin.com) for products to complete your plow system.

## TOOLS REQUIRED

- Safety Glasses
- Socket Set, Metric
- Torque Wrench
- Wrench Set, Metric
- Drill
- 1/2" Drill Bit

## KIT CONTENTS

Item	Qty	Part Description	Part Number
1	1	Pioneer Mounting Bracket	-
2	2	Hex Bolt, Zinc Plated, M12-1.75 x 45mm LG	-
3	2	Hex Flange Locknut, Zinc Plated, M12-1.75	-
4	2	Hex Bolt, Zinc Plated, M10-1.25 x 30mm LG	-
5	2	Flat Washer, Zinc Plated, M10	-
6	2	Lock Washer, Zinc Plated, M10	-
7	1	Instruction Guide (not shown)	-

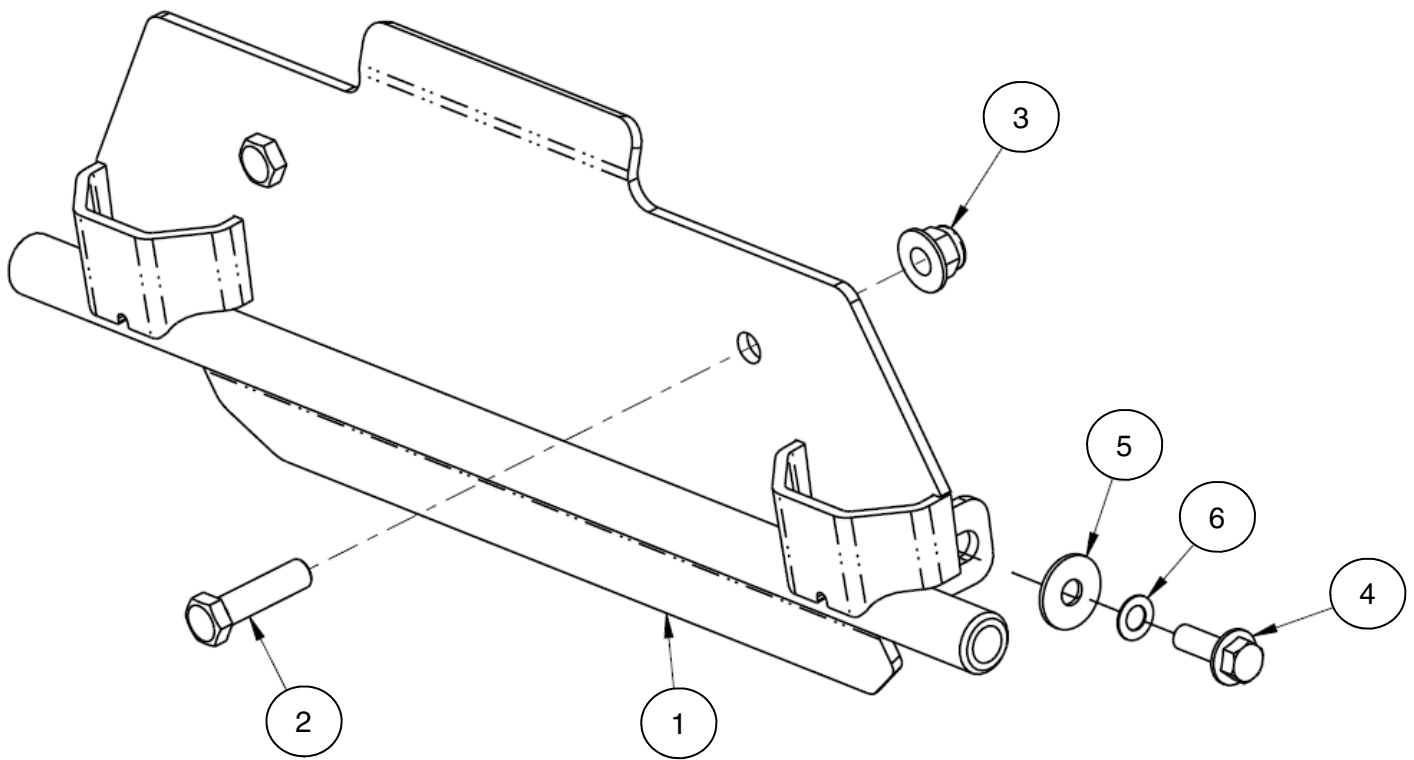



# INSTALLATION INSTRUCTIONS

## VEHICLE PREPARATION

### GENERAL

1. Park vehicle on a flat surface.
2. Shift vehicle into park.
3. Turn key to OFF position and remove key.
4. Remove the lower bumper screws on each side, two total. (See illustration 1-1). **Note, OEM screws will not be re-used with plow mounting plate. Save for install when plow mount is removed during off-season.**

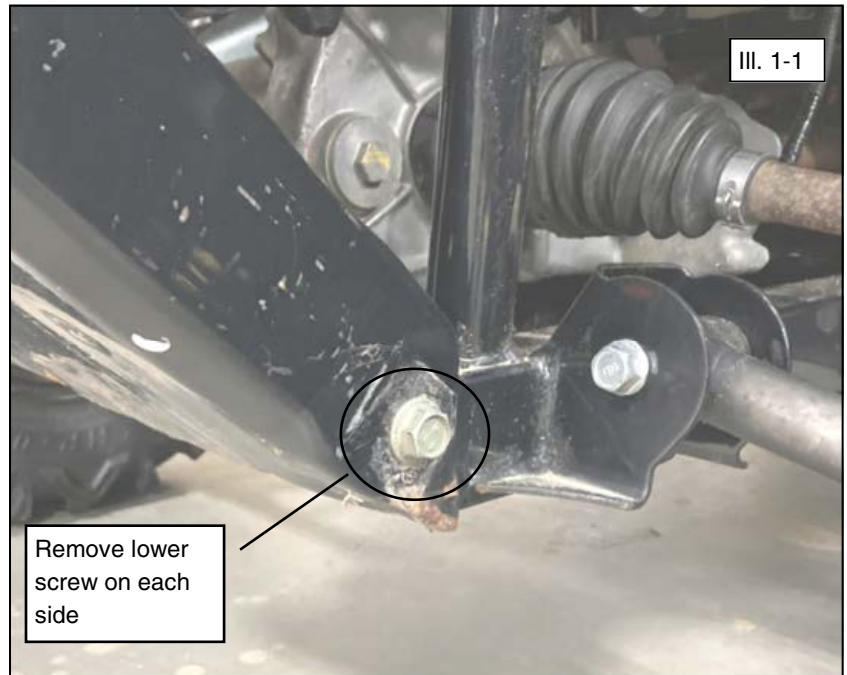

## ACCESSORY INSTALLATION

5. Position mounting bracket (item #1) on vehicle front bumper and loosely install mount using the two M10 screws (item #4) with lock washers (item #6) and flat washers (item #5). (See illustration 1-2). **Note, do not tighten hardware at this time.**
6. The mount bracket will be used as a template to mark the upper holes for drilling. Remove the mount bracket and drill the holes using 1/2" drill bit. (See illustration 1-3). **Note, the drilled holes will have exposed metal, touch-up the exposed edges using black spray paint.**

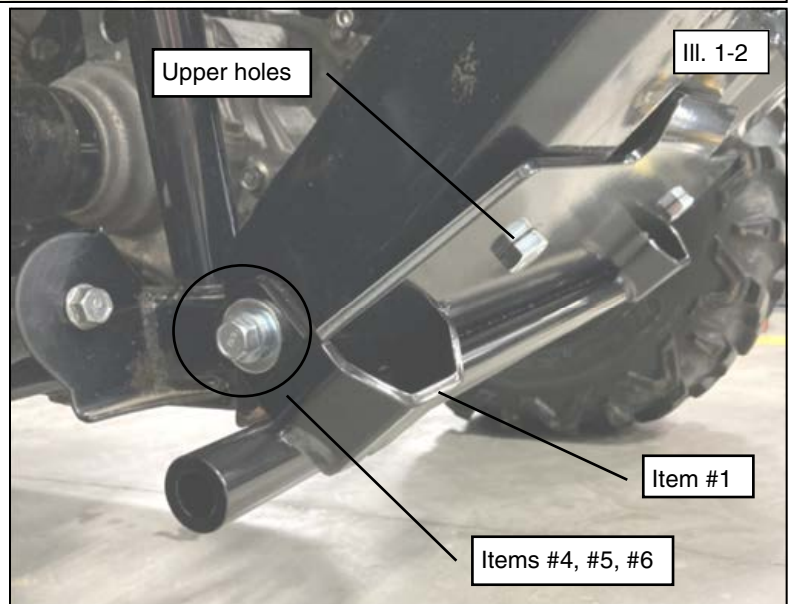

## ACCESSORY INSTALLATION

(continued)

7. Install the mount bracket (item #1) using the M10 hardware (items #4, #5, #6) through the mounting plate side tabs into the vehicle bumper. Install the two upper M12 screws (item #2) with two M12 locknuts (item #3) through the drilled holes into the vehicle bumper. (See illustrations 1-4 and 1-5).

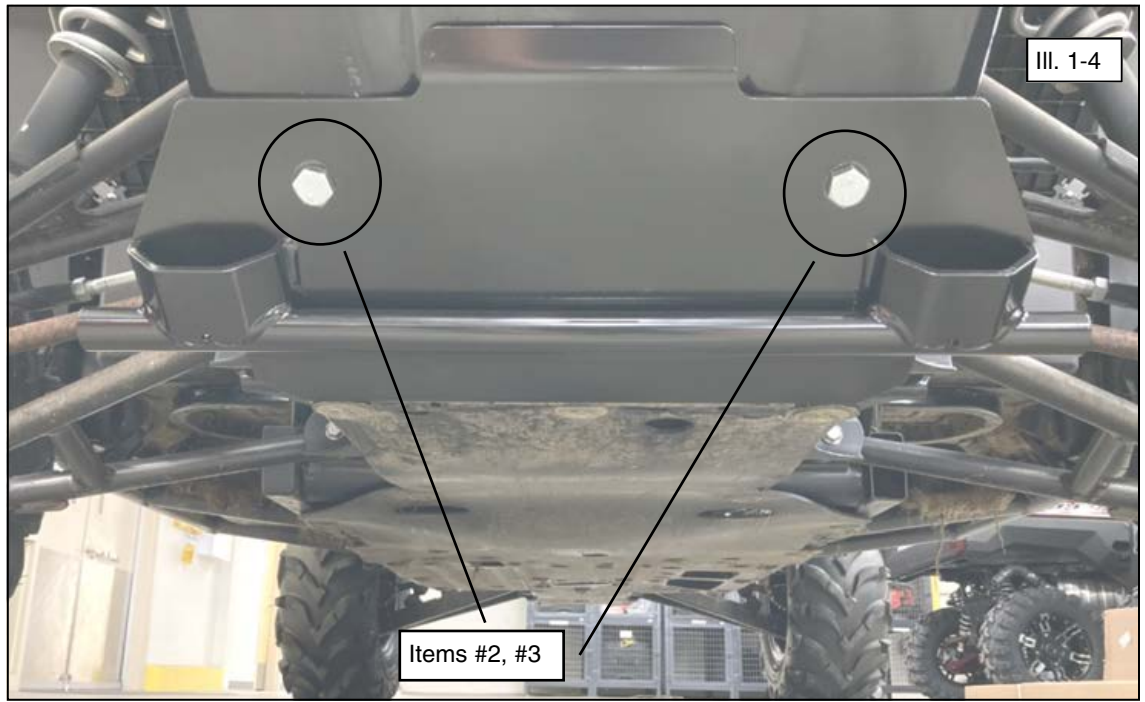

8. Tighten all hardware to specification.

 = T
<b>10MM FASTENER TORQUE:</b> 34 ft. lbs. (46 Nm)

 = T
<b>12MM FASTENER TORQUE:</b> 34 ft. lbs. (46 Nm)

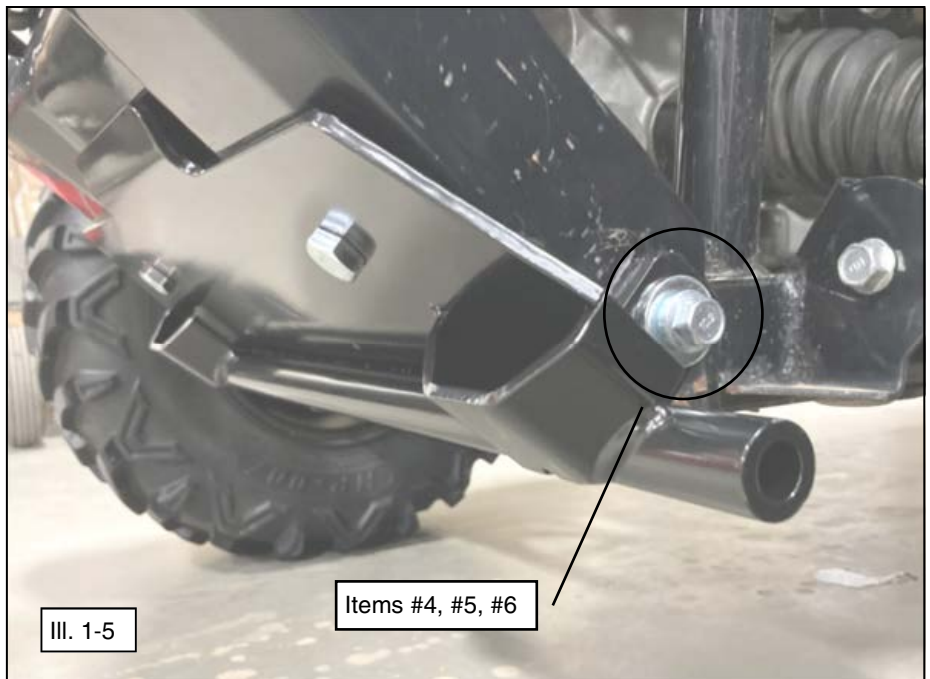

## WARRANTY



### Two Year Limited Warranty

For the period of two (2) years from the purchase date, Kolpin will replace for the original purchaser, free of charge, any part or parts found upon examination by Kolpin to be defective in material, workmanship, or both.

All transportation costs incurred submitting product to Kolpin for warranty consideration must be borne by the purchaser. If Kolpin determines that the product must be returned to the factory for credit, please call 1-877-956-5746 for a Return Merchandise Authorization (RMA) number and shipping instructions.

This warranty does not apply to parts that have been damaged by accident, alteration, abuse, improper maintenance, normal wear, or other causes beyond the manufacturer's control. In order to protect you and your ATV, certain parts of the plow system and/or hardware are designed to fail when the equipment is over-stressed. Parts that are lost due to loosening and improper maintenance are not covered under warranty. This warranty does not cover removal or reinstallation labor fees of the plow system and related components.

Peripheral products such as engines, electric motors, and actuators may carry an original manufacturer's warranty. Most hardware is general in nature and is easily obtained locally. Be sure to replace with minimum metric class 8.8 specification.

**Kolpin Outdoors, Inc.**

**Telephone: (763)-478-5800**

**Toll Free: (877)-956-5746**

**Fax Number: (800)-245-7569**

**[www.kolpin.com](http://www.kolpin.com)**

**Email: [customerservice@kolpin.com](mailto:customerservice@kolpin.com)**